



The Quality Name in High Voltage Switching

## **Type WAG and WAG-A**

Aluminum Vertical  
Break Disconnect  
Switch

**Volt: 15.5-170kV**

**Amp: All**

**INSTALLATION &**

**INSTRUCTION**

**MANUAL**



# Safety Information

## DANGER

IMPROPER HANDLING, INSTALLATION, OPERATION OR MAINTENANCE OF THIS EQUIPMENT MAY CAUSE IMMEDIATE HAZARDS WHICH WILL LIKELY RESULT IN SERIOUS PERSONNEL INJURY OR DEATH.

## WARNING

The equipment covered by this publication must be handled, installed, operated and maintained by qualified persons who have direct knowledge and experience dealing with the hazards involved and are thoroughly trained in the handling, installation, operation and maintenance of high voltage transmission and distribution equipment. These instructions are meant for only such **Qualified Persons**. They are not intended to be a substitute for adequate training and experience in safety procedures for this type of equipment.

A **Qualified Person** is one who is trained in and has skills necessary:

- to read and comprehend this instruction book – understanding that these instructions are general in nature
- to accept personal responsibility to prepare and maintain an intrinsically safe work environment and maintain control of the work site to safeguard all persons present
- to develop and implement a proper rigging, lifting, and installation plan along with all safety precautions required to insure safe and proper lifting and installation of the equipment.
- to distinguish between energized and non energized parts
- to determine proper approach distances to energized parts
- to properly work with and around energized or de-energized equipment that may be pressurized with gas
- for proper use of personal protective equipment, insulating and shielding materials, insulated tools for working near energized and /or pressurized electrical equipment
- to recognize and take necessary precautions for the unique and dynamic conditions of site and specialized equipment to maintain a safe work environment during handling, installation, operation, and maintenance of high voltage switching equipment

The instructions in this manual are general guidelines for this type of equipment and not specific to the equipment supplied. Portions of it may not be applicable or may not have complete instructions for your specific equipment.

If you do not understand any part of these instructions or need assistance, contact Southern States Service Division at 770-946-4562 during normal business hours (EST) or 770-946-4565 after normal business hours.



## LIMITED WARRANTY

Southern States, LLC (“SLLC”) warrants only to the Warranty Holder (hereinafter defined as the “End User” or the “Immediate Purchaser”, as applicable, pursuant to the terms and conditions of this Limited Warranty as set forth below), that the Product identified below will, upon shipment, be free of defects in workmanship and material for the applicable Warranty Period. The “Warranty Period” is that period of time during which this Limited Warranty is effective, and such period begins on the invoice date issued by SLLC for the Product, and continues until the earlier to occur of (1) the expiration of the Warranty Duration period, or (2) the Number of Operations, both as specified in the table below. If the Product is both purchased and installed within the United States or Canada, this Limited Warranty is granted to each end user of the Product who acquired the Product for its own use during the Warranty Period (“End User”). In all other situations, this Limited Warranty is granted only to the first purchaser of the Product (“Immediate Purchaser”) from SLLC. No primary or remote purchaser or owner of the Product who is not a Warranty Holder may claim any benefit under this Limited Warranty, or any remedial promise included in this Limited Warranty. SLLC shall, upon prompt written notice from the Warranty Holder, correct a nonconforming Product by repair or replacement at the sole discretion of SLLC of the nonconforming Product or any part or component of a nonconforming Product necessary in SLLC’s discretion to make such Product conforming. Any transportation charges, labor for removing, reinstalling the Product or part, and/or costs related to providing access to the Product shall be the responsibility of the Warranty Holder. Correction in this manner will constitute the Warranty Holder’s exclusive remedy and fulfillment of all SLLC’s liabilities and responsibilities hereunder. SLLC’s duty to perform under this limited warranty may be delayed, at SLLC’s sole option, until SLLC has been paid in full for all products purchased by the Warranty Holder. No such delay will extend the Warranty Period. If SLLC does not make such repair or replacement, SLLC’s liability for damages on account of any claimed nonconformity will in no event exceed the purchase price of the Product in question. This Limited Warranty does not apply to any Product that has been disassembled, repaired, or altered by anyone other than SLLC. This Limited Warranty will not apply to any Product that has been subjected to improper or abnormal use of the Product. SLLC has no responsibility to repair or replace any Product or component thereof manufactured by another party, but SLLC will assign, to the extent assignable, to the Warranty Holder any manufacturers’ warranty that applies to products and components not manufactured by SLLC.

**THIS LIMITED WARRANTY IS EXCLUSIVE AND IN LIEU OF ALL OTHER WARRANTIES. THERE ARE NO OTHER EXPRESS, IMPLIED, OR STATUTORY WARRANTIES. ALL IMPLIED WARRANTIES WHICH MAY ARISE BY IMPLICATION OF LAW, OR APPLICATION OF COURSE OF DEALING OR USAGE OF TRADE, INCLUDING, BUT NOT LIMITED TO, IMPLIED WARRANTIES OF MERCHANTABILITY OR FITNESS FOR A PARTICULAR PURPOSE, NONINFRINGEMENT OR OTHERWISE ARE EXPRESSLY EXCLUDED. SLLC SHALL NOT BE LIABLE OR RESPONSIBLE FOR ANY CONSEQUENTIAL, INCIDENTAL, INDIRECT, EXEMPLARY, SPECIAL, OR PUNITIVE DAMAGES, EVEN IF SLLC HAS BEEN ADVISED OF THE POSSIBILITY OF SAME. THE WARRANTY HOLDER IS SOLELY RESPONSIBLE FOR THE SUITABILITY OF THE PRODUCT FOR ANY PARTICULAR APPLICATION.**

Product Purchased Region	Product Installed Region	Warranty Holder	Warranty Duration
U.S and Canada	U.S and Canada	End User	Five (5) Years
All Other Conditions		Immediate Purchaser	Earlier of 1 year from installation or 18 months from shipment

# Types WAG and WAG-A 69-230kV all ampere ratings

## Installation Instructions

Southern States switches designated Types WAG and WAG-A in the 69 through 230 kv range come in current ratings from 1,200 up to 6,000 continuous amperes. The drawings on this page show the basic design configurations of these switch lines; however, individual differences may exist between different models due to different mounting schemes, insulator sizes, and customer requirements. But regardless of their appearance, all WAG and WAG-A switches share basic mechanical details, and the installation procedure is the same for all.

Since these switches are normally shipped without insulators, installation consists of removing the live parts from the base, mounting the base on the structure, mounting the insulators to the base, mounting the live parts to the insulators, and in some cases, minor adjustments to the live parts.

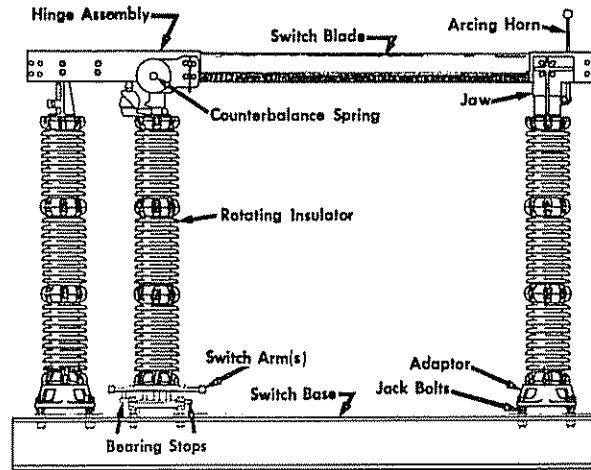

Identification of parts

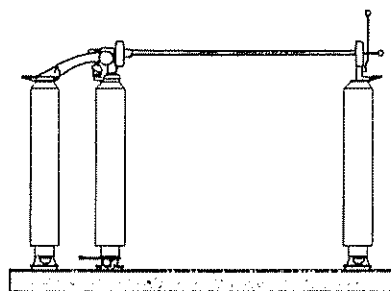

WAG 1200 Amp

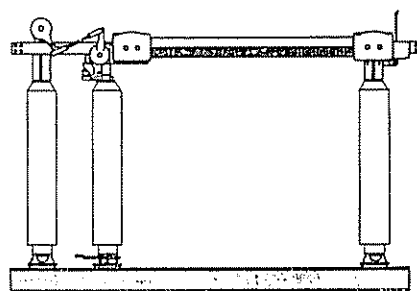

WAG 3000 Amp

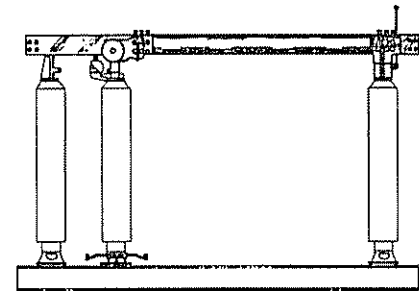

WAG-A 4000 Amp

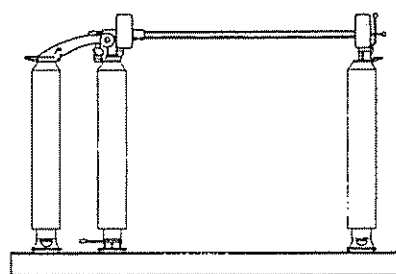

WAG 1600 Amp

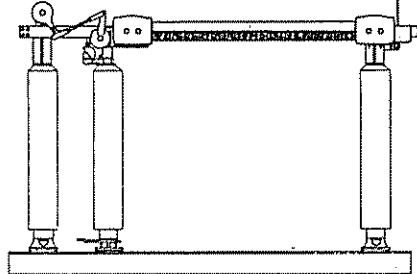

WAG 4000 Amp

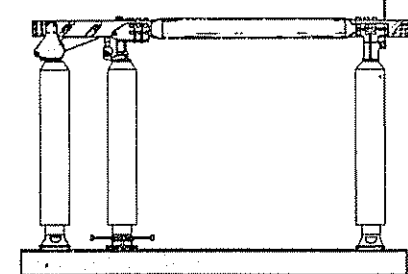

WAG-A 5000 Amp

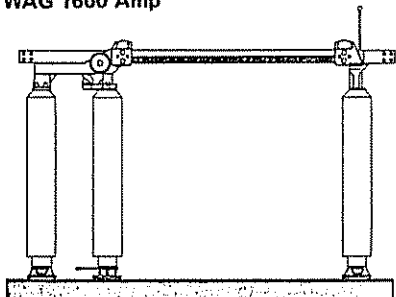

WAG 2000 Amp

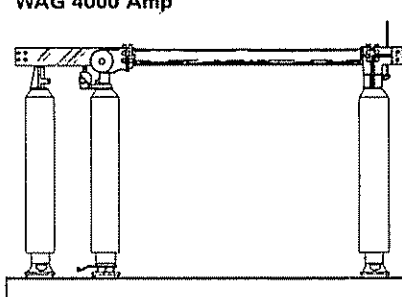

WAG-A 3000 Amp

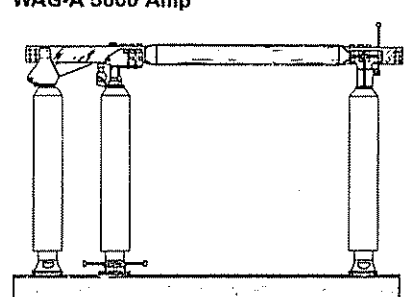

WAG-A 6000 Amp

NOTE: The drawings in this manual are for illustration only and may differ in actual appearance from your switch.

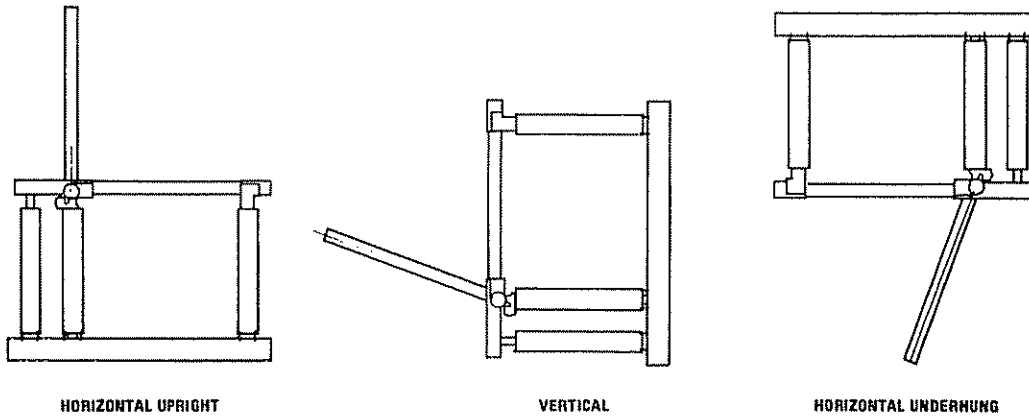

FIGURE 1 Definition of mounting positions

**FIELD ASSEMBLY:**

*These switches may be assembled on the structure, or assembled on the ground and hoisted to the structure according to preference. (Exception: It is recommended that vertical mounted switches be assembled on the ground.) When assembling switches on the ground, be sure the base rests on a firm, level surface. When hoisting switches, LIFT BY THE SWITCH BASE ONLY.*

*Before mounting the switches on the structure, refer to the Op. Mech. Drawing because there may be differences in the switch poles that require that they be mounted in specific locations.*

*Do not change any factory setting on the switch unless directed to in this manual.*

1. Uncrate the switches, remove the shipping tie-down wires, and check for damage in transit. If any damage is found, immediately file a claim with the carrier and notify the factory.
2. Using any convenient means, match mark the lower parts of the hinge assembly with the switch arm and the rotating hub to insure correct re-assembly as shown in figure 2.

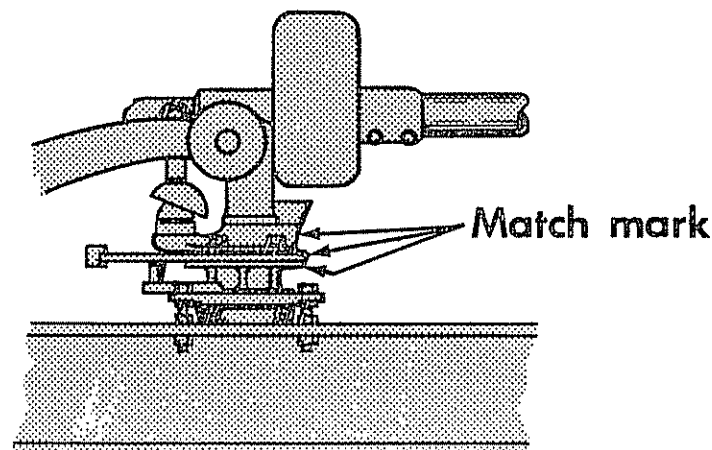

Figure 2

NOTE: Switch arm shown in normal position.  
In some applications switch arm may be reversed, or double switch arms may be used.

3. Rotate the switch arm to relieve the contact pressure on the switch blade. Remove the live parts from the adaptors and save the bolts for re-use (IF they are of a type specified on the Unit Assembly Drawing for insulator mounting – galvanized, stainless steel, or bronze).  
*NOTE: Some poles may have an auxiliary switch arm. Check the Op. Mech. Drawing for proper adjustment of this arm.*
4. Mount the insulators as indicated in figure 3 using the bolts specified in the field assembly bolt list (SF Drawing). Be sure that the match marks made earlier line up.

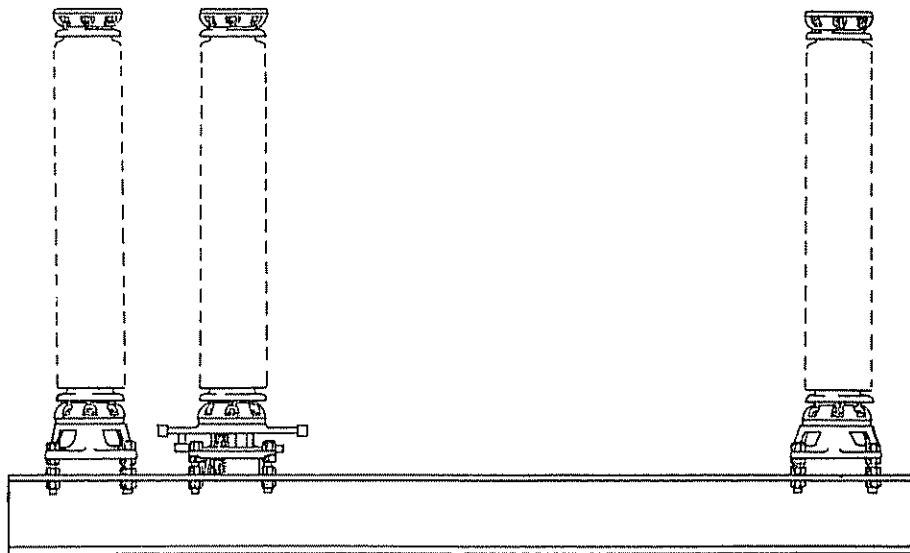
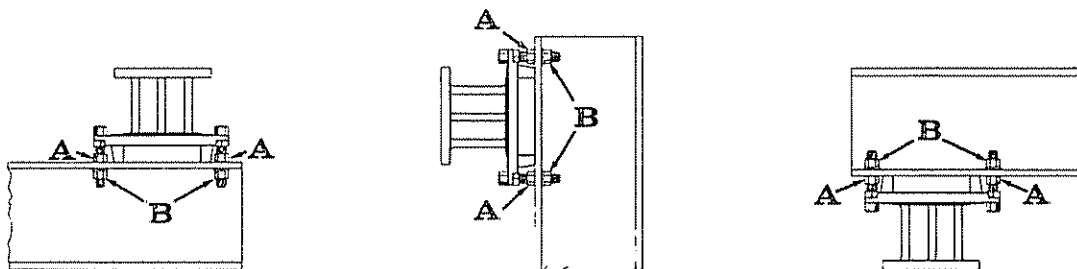

Figure 3

5. It is important that the center insulator be as nearly perpendicular to the base as possible. Plumb this insulator stack. If necessary, adjust the jack bolts on the bearing as directed in figure 4 until the center insulator is 90° to both the long and short axis of the base.

**NOTE:** When adjusting jack bolts it is important that the actual height of the insulator remain the same. To do this, adjust opposite bolts equally; that is, run one nut up a certain number of turns, and run the other one down the same amount of turns. (By doing this, the insulator stack will remain at its original height, but its angle of tilt will change.)



**UPRIGHT**

To adjust the insulator stack, loosen all four nuts (B). Tilt insulator to required position by screwing up or down on nuts (A). Retighten nuts (B).

**VERTICAL**

To adjust the insulator stack, loosen both top nuts (A) and bottom nuts (B). Tilt insulator to required position by running bottom nuts "A" in or out and top nuts "B" in or out. Retighten opposite nuts.

**UNDERHUNG**

To adjust the insulator stack, first loosen all four nuts (A). Tilt insulator to required position by screwing up or down on nuts (B). Retighten nuts (A).

6. Mount the hinge and blade assembly as directed in figure 5. Be sure that the match marks made earlier are aligned.

*NOTE: Some switch models may use 1/2" spacers between the live parts and the top of the insulators. When assembling the switch, make sure these spacers are replaced atop the same insulator stack that they were shipped on.*

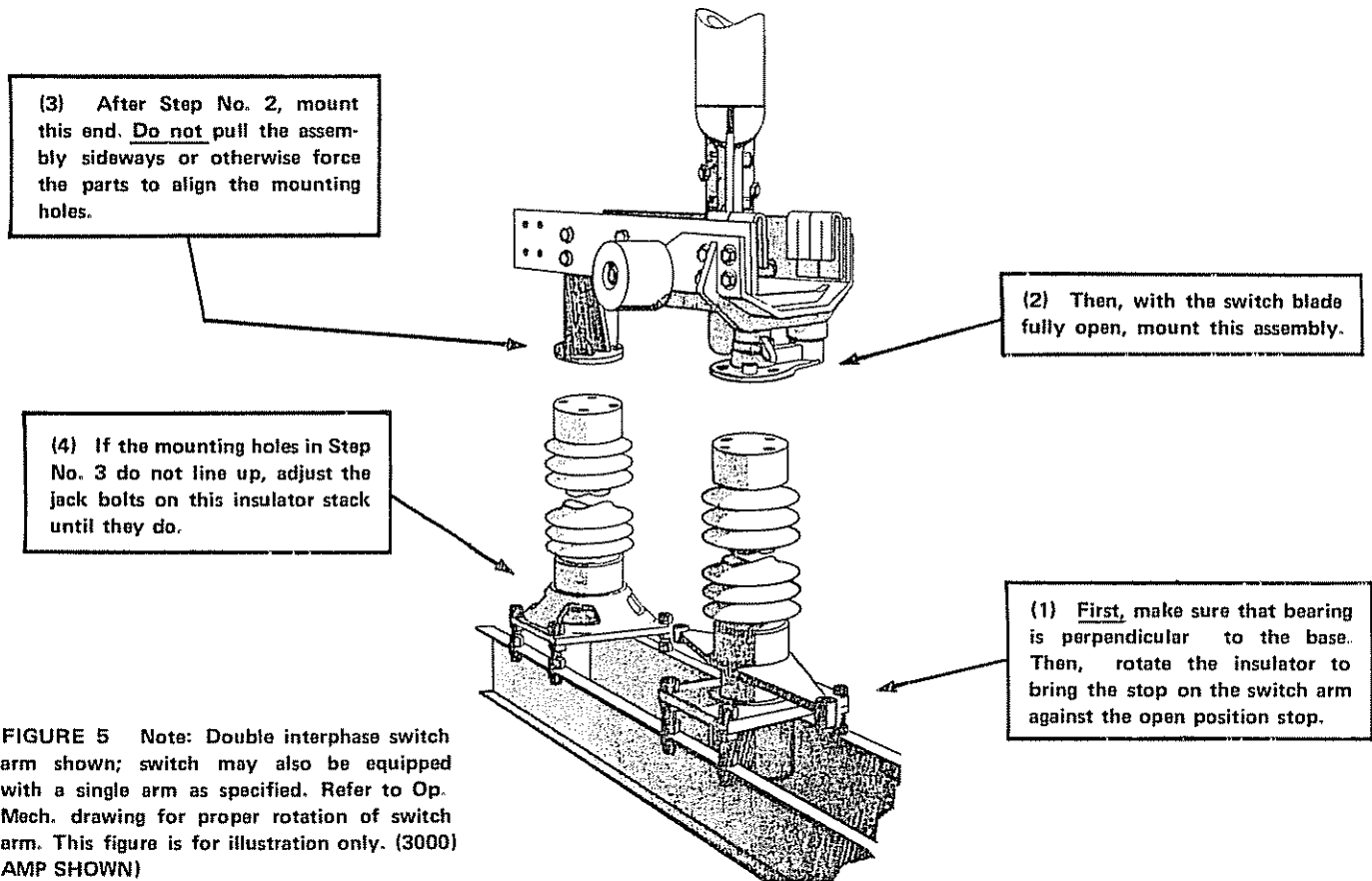

*NOTE: If applicable, at this time also mount accessories such as: grounding switch jaw, quick break device, outriggers, etc. as shown on the Op. Mech. Drawing. Use the spacers provided to maintain equal height of the live parts on the rotating and the stationary insulators.*

7. Mount the jaw. Leave the mounting bolts loose, close the switch, and tighten the mounting bolts. Adjust the jack bolts at the bottom of the jaw stack (only) if necessary.

*NOTE: If possible, install the conductors at this time to avoid the possibility of having to readjust the insulators later due to unequal conductor loads on the terminals.*

8. If the switch has been assembled on the ground, at this time mount it on the structure. **LIFT BY THE SWITCH BASE ONLY.**

9. Hand operate each pole to check for proper contact engagement. The blade should enter the jaw centrally as shown in figure 6 without dragging on either side. Additionally, it must come to rest with the silver of the blade centered in the silver of the contact leaves as shown in figure 7. Adjust the jack bolts at the base of the jaw insulator to achieve proper contact alignment.

The switch is fully closed and will have adequate contact pressure if the blade has rotated to within plus or minus 5° of perpendicular in the contacts as shown in figure 8.

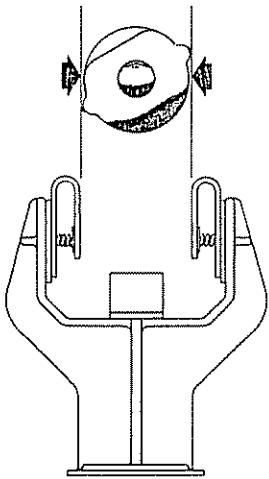

Figure 6

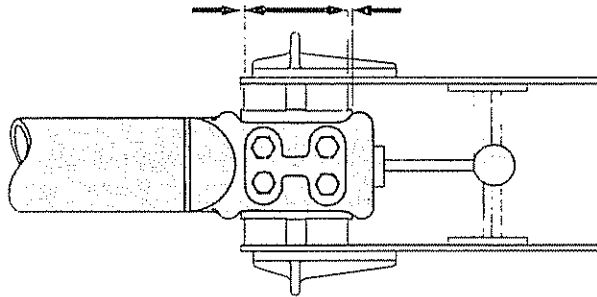

Figure 7 Blade tip centered in jaw contacts

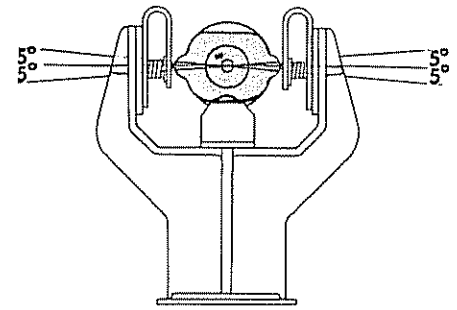

Figure 8

10. If applicable, install the arcing horn on the jaw. The horns should touch *lightly* throughout their stroke. Arcing horns rubbing together with excessive pressure can cause the blade to rotate outside the contacts causing switch malfunction. Bend the stationary horn as required to achieve enough pressure for contact, but not so much as to cause binding.
11. When all adjustments are made, install the operating mechanism as directed on the following pages.

*NOTE: After installing conductors it may be necessary to readjust the insulators due to unequal loadings on the terminals.*

INSTALLATION INSTRUCTIONS

Generally speaking, the same method is used to operate all types of switches, the only difference being in relatively minor details made necessary by different types of structures, different requirements for vertical pipe rotations, clearances, etc.

Although the drawing shown in Figure 1 is of a 69 kv vertical break switch, it may be used as a general example of operating mechanisms for all Southern States switches regardless of mounting positions. The operating pipes may be arranged in any of 4 basic ways as shown schematically in figure 2; however, the operating principle remains the same, and the method of installation and adjustment is virtually identical:

NOTE: Some installations of higher amperage switches will have a double interphase pipe (Item 15). In which case one switch pole will always have an auxiliary switch arm as shown in illustration "A" below.

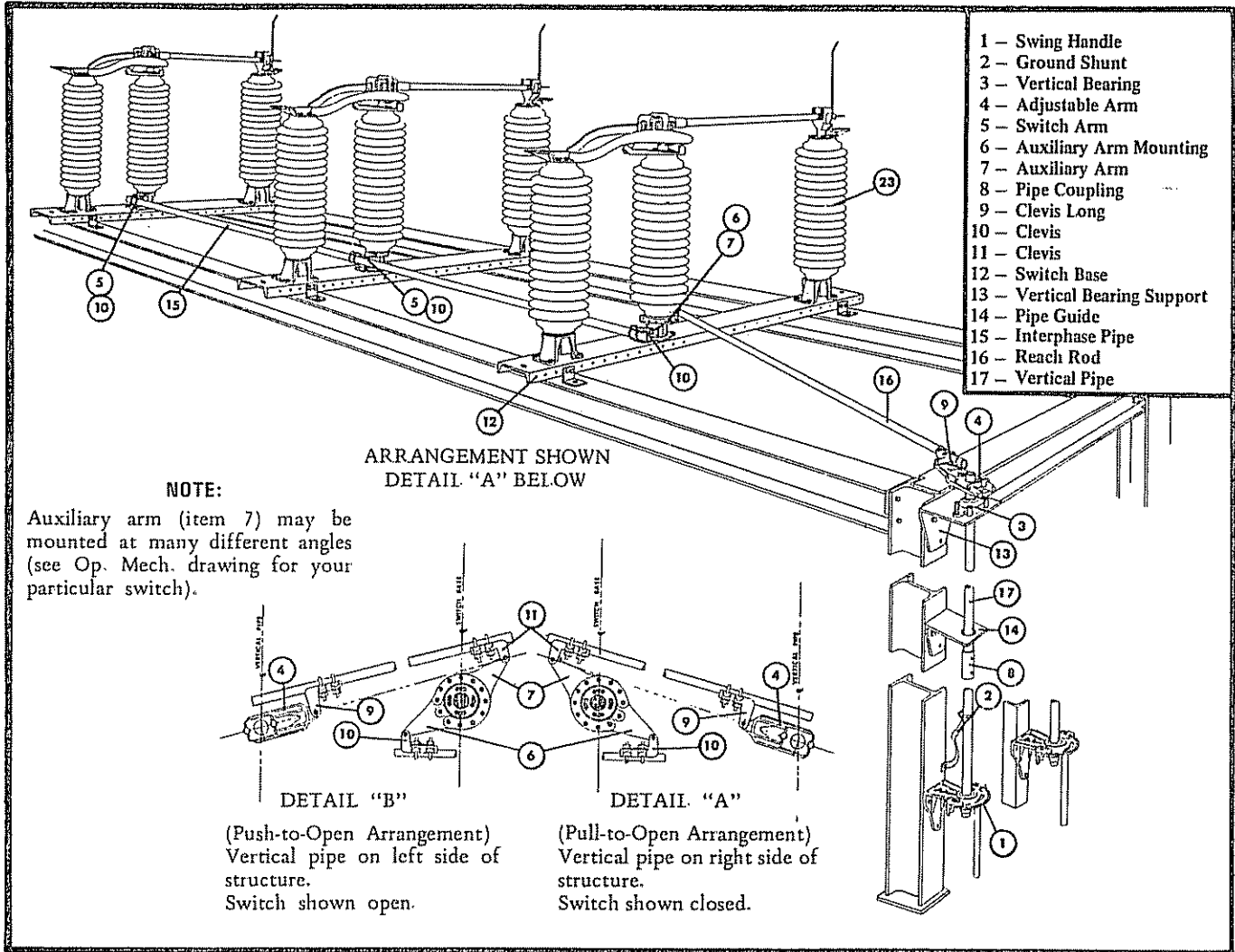

Figure 1

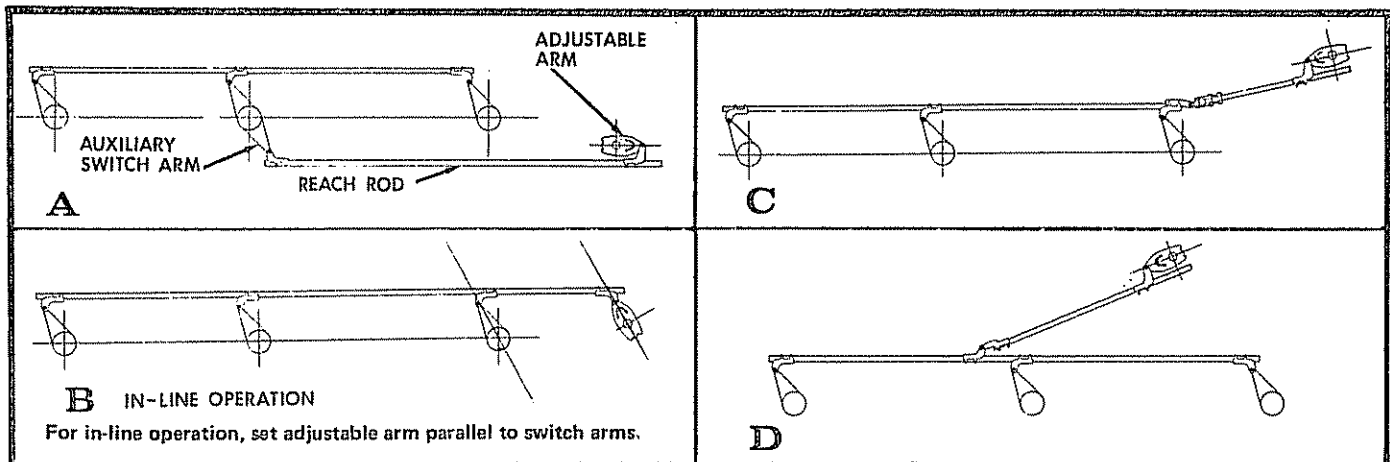

Figure 2

- I. Included with every switch is an Operating Mechanism Drawing (Op. Mech. Drawing). Study this drawing carefully, and with all switch poles closed, install mounting brackets, bushings, manual operating devices (if used), vertical pipe, adjustable crank arm, reach rod, and interphase pipe. *Be sure that pipe collar above the vertical bearing supports the full weight of the vertical pipe.*

**IMPORTANT:** On some installations you will find self-piercing set screws in the pipe clevises. These screws should be tightened to only grip the pipe during initial adjustments: Do not pierce the pipe until directed to do so.

**NOTE:** When a switch pole is equipped with an auxiliary arm, the best method for operating mechanism attachment is to wait until after this pole is completely adjusted before installing the interphase pipe. (This will eliminate trying to coordinate and adjust all three poles at once.)

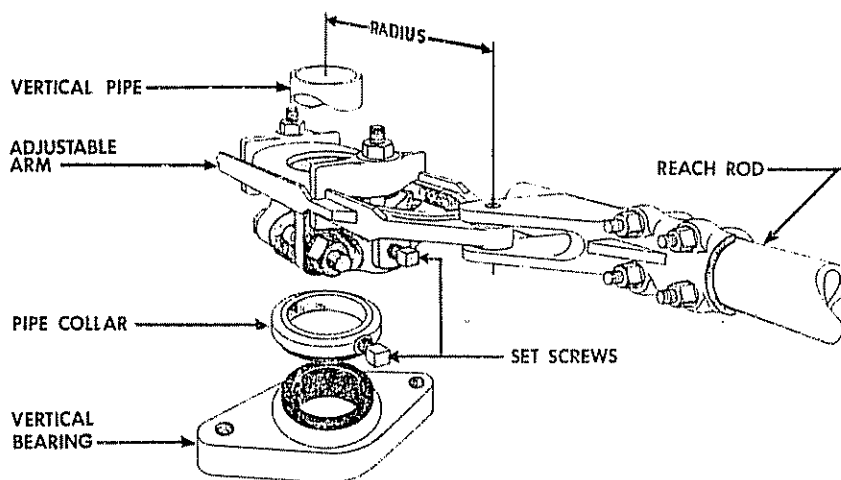

Figure 13 — Adjustable arm assembly. **CAUTION:** Pipe collar must support full weight of pipe.

- II. After mounting all operating mechanism components, use any convenient means to match mark all clevis connections, adjustable arm, and manual operator attachment to check for slippage during trial operations.
- III. If a motor operator is to be used, at this point refer to the motor operator installation instructions for mounting and trial operations.
- IV. Place all switch poles in the fully closed position.

ADJUSTMENT:

*Do not use electrical operation until all line switch adjustments are made.*

1. The adjustable arm should travel 180° from toggle closed to toggle open. Manually test operate.
2. If the switch does not fully open, the radius of the arm is too short. To correct:
  - a. Check first to see that nothing has slipped.
  - b. Return the switch to the closed position.
  - c. Loosen the adjustable arm and clevis bolts as shown in figure 17.
  - d. Lengthen the radius of the adjustable arm about 1/4 inch and allow the clevis to reposition itself the same distance (shortening the pipe).
  - e. Test operate again and adjust as necessary.

FIGURE 17

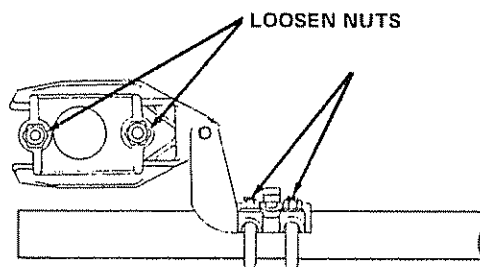

3. If the switch is fully open before the control handle reaches the open position, the radius of the adjustable arm is too long. To correct:
  - a. Check to see that nothing has slipped.
  - b. Return the switch to the closed position.
  - c. Loosen the adjustable arm and clevis bolts as shown in figure 17.
  - d. Shorten the radius of the adjustable arm about 1/4 inch and allow the clevis to reposition itself (lengthening the pipe).
  - e. Test operate again and adjust as necessary.
4. When the switch is completely adjusted, securely tighten all bolts, and tighten all set screws until the pipe walls are pierced. (For heavy wall pipe, drill the set screw holes, using the threaded drill guides supplied and a 1/4" drill.

## INSTALLATION INSTRUCTIONS

**Direct Mechanisms**

The direct operating mechanism is sometimes used on lower rated switches (usually 69 kv and below). It is a much simpler method of switch operation since the vertical operating pipe is attached directly to a bearing shaft that extends below the base of one of the switch poles:

- A. Study the Op. Mech. Drawing for arrangement of operating pipes.
- B. Pull all switch poles in the fully closed position.
- C. Attach interphase clevises and interphase pipe. Tighten clevis U-bolts.
- D. Attach all mounting brackets to structure as shown on the Op. Mech. Drawing. Insure that pipe bushing and support is positioned as shown on this drawing.
- E. Attach universal coupling to extended switch bearing shaft. (See Fig. 5)

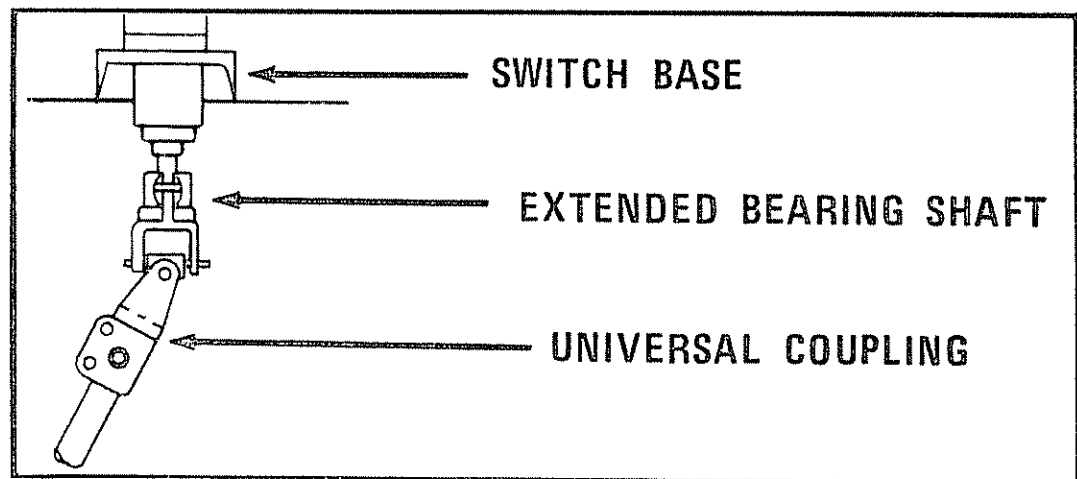

FIGURE 5

- F. Install vertical pipe and pipe couplings (if required).
- G. Manual handle stops are factory set and do not usually require readjustment.
- H. Check contact engagement after both jaw and hinge conductors have been attached to switch terminal pads. Switch blade should enter jaw centrally with equal clearance on either side of the blade. Adjust insulators as necessary to achieve proper blade clearance.
- I. When all adjustments are completed and switch operates satisfactorily, tighten all operating mechanism set screws until pipe walls are pierced. In cases where heavy wall pipe is supplied, it will be necessary to pre-drill the pipe using the threaded drill guide supplied and a 1/4" drill.
- J. Make final check of all bolts, screws, nuts, and cotter pins for security.



**The Quality Name in High Voltage Switching**

30 Georgia Avenue  
Hampton, Georgia 30228  
Phone: 770-946-4562  
Fax: 770-946-8106  
E-mail: [support@southernstatesllc.com](mailto:support@southernstatesllc.com)  
<http://www.southernstatesllc.com>

©2015 Southern States, LLC  
IB-106-WAG.WAG-A 230-Rev 1 100815 Printed U.S.A.