



The Quality Name in High Voltage Switching

Type SSB-T Copper
Single Side Break
Disconnect Switch
15.5-72.5 kV, 1200A

INSTALLATION &

INSTRUCTION

MANUAL

Safety Information

DANGER

IMPROPER HANDLING, INSTALLATION, OPERATION OR MAINTENANCE OF THIS EQUIPMENT MAY CAUSE IMMEDIATE HAZARDS WHICH WILL LIKELY RESULT IN SERIOUS PERSONNEL INJURY OR DEATH.

WARNING

The equipment covered by this publication must be handled, installed, operated and maintained by qualified persons who have direct knowledge and experience dealing with the hazards involved and are thoroughly trained in the handling, installation, operation and maintenance of high voltage transmission and distribution equipment. These instructions are meant for only such **Qualified Persons**. They are not intended to be a substitute for adequate training and experience in safety procedures for this type of equipment.

A **Qualified Person** is one who is trained in and has skills necessary:

- to read and comprehend this instruction book – understanding that these instructions are general in nature
- to accept personal responsibility to prepare and maintain an intrinsically safe work environment and maintain control of the work site to safeguard all persons present
- to develop and implement a proper rigging, lifting, and installation plan along with all safety precautions required to insure safe and proper lifting and installation of the equipment.
- to distinguish between energized and non energized parts
- to determine proper approach distances to energized parts
- to properly work with and around energized or de-energized equipment that may be pressurized with gas
- for proper use of personal protective equipment, insulating and shielding materials, insulated tools for working near energized and /or pressurized electrical equipment
- to recognize and take necessary precautions for the unique and dynamic conditions of site and specialized equipment to maintain a safe work environment during handling, installation, operation, and maintenance of high voltage switching equipment

The instructions in this manual are general guidelines for this type of equipment and not specific to the equipment supplied. Portions of it may not be applicable or may not have complete instructions for your specific equipment.

If you do not understand any part of these instructions or need assistance, contact Southern States Service Division at 770-946-4562 during normal business hours (EST) or 770-946-4565 after normal business hours.



LIMITED WARRANTY

Southern States, LLC (“SLLC”) warrants only to the Warranty Holder (hereinafter defined as the “End User” or the “Immediate Purchaser”, as applicable, pursuant to the terms and conditions of this Limited Warranty as set forth below), that the Product identified below will, upon shipment, be free of defects in workmanship and material for the applicable Warranty Period. The “Warranty Period” is that period of time during which this Limited Warranty is effective, and such period begins on the invoice date issued by SLLC for the Product, and continues until the earlier to occur of (1) the expiration of the Warranty Duration period, or (2) the Number of Operations, both as specified in the table below. If the Product is both purchased and installed within the United States or Canada, this Limited Warranty is granted to each end user of the Product who acquired the Product for its own use during the Warranty Period (“End User”). In all other situations, this Limited Warranty is granted only to the first purchaser of the Product (“Immediate Purchaser”) from SLLC. No primary or remote purchaser or owner of the Product who is not a Warranty Holder may claim any benefit under this Limited Warranty, or any remedial promise included in this Limited Warranty. SLLC shall, upon prompt written notice from the Warranty Holder, correct a nonconforming Product by repair or replacement at the sole discretion of SLLC of the nonconforming Product or any part or component of a nonconforming Product necessary in SLLC’s discretion to make such Product conforming. Any transportation charges, labor for removing, reinstalling the Product or part, and/or costs related to providing access to the Product shall be the responsibility of the Warranty Holder. Correction in this manner will constitute the Warranty Holder’s exclusive remedy and fulfillment of all SLLC’s liabilities and responsibilities hereunder. SLLC’s duty to perform under this limited warranty may be delayed, at SLLC’s sole option, until SLLC has been paid in full for all products purchased by the Warranty Holder. No such delay will extend the Warranty Period. If SLLC does not make such repair or replacement, SLLC’s liability for damages on account of any claimed nonconformity will in no event exceed the purchase price of the Product in question. This Limited Warranty does not apply to any Product that has been disassembled, repaired, or altered by anyone other than SLLC. This Limited Warranty will not apply to any Product that has been subjected to improper or abnormal use of the Product. SLLC has no responsibility to repair or replace any Product or component thereof manufactured by another party, but SLLC will assign, to the extent assignable, to the Warranty Holder any manufacturers’ warranty that applies to products and components not manufactured by SLLC.

THIS LIMITED WARRANTY IS EXCLUSIVE AND IN LIEU OF ALL OTHER WARRANTIES. THERE ARE NO OTHER EXPRESS, IMPLIED, OR STATUTORY WARRANTIES. ALL IMPLIED WARRANTIES WHICH MAY ARISE BY IMPLICATION OF LAW, OR APPLICATION OF COURSE OF DEALING OR USAGE OF TRADE, INCLUDING, BUT NOT LIMITED TO, IMPLIED WARRANTIES OF MERCHANTABILITY OR FITNESS FOR A PARTICULAR PURPOSE, NONINFRINGEMENT OR OTHERWISE ARE EXPRESSLY EXCLUDED. SLLC SHALL NOT BE LIABLE OR RESPONSIBLE FOR ANY CONSEQUENTIAL, INCIDENTAL, INDIRECT, EXEMPLARY, SPECIAL, OR PUNITIVE DAMAGES, EVEN IF SLLC HAS BEEN ADVISED OF THE POSSIBILITY OF SAME. THE WARRANTY HOLDER IS SOLELY RESPONSIBLE FOR THE SUITABILITY OF THE PRODUCT FOR ANY PARTICULAR APPLICATION.

Product Purchased Region	Product Installed Region	Warranty Holder	Warranty Duration
U.S and Canada	U.S and Canada	End User	Five (5) Years
All Other Conditions		Immediate Purchaser	Earlier of 1 year from installation or 18 months from shipment

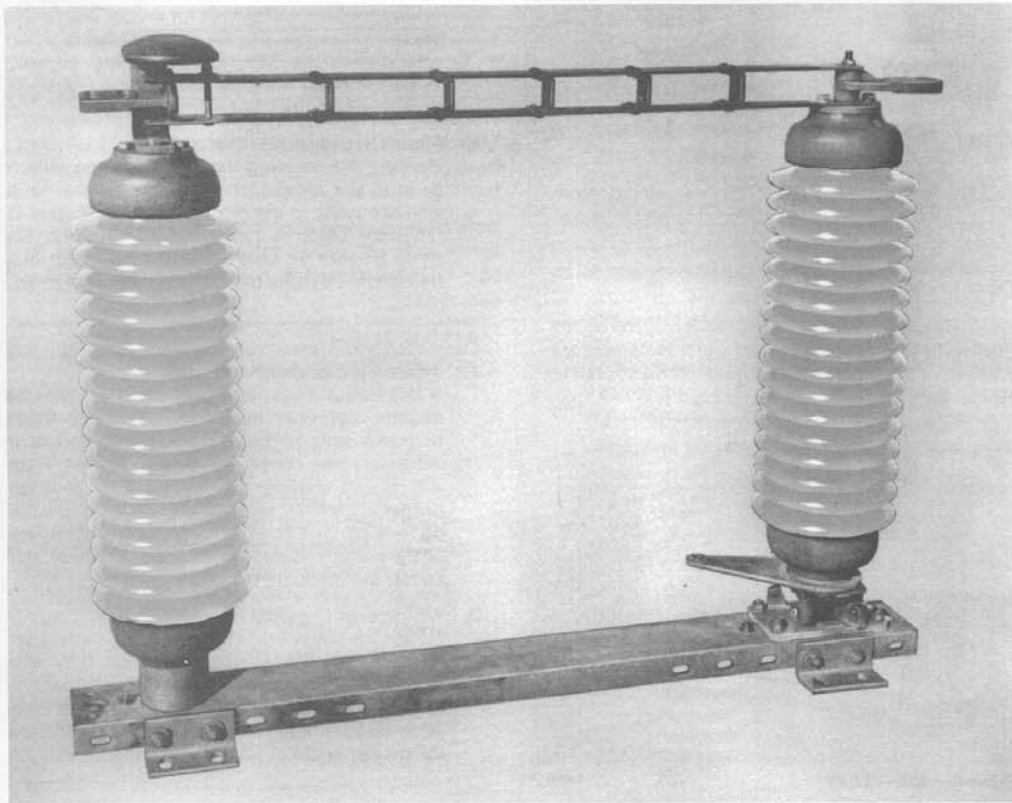

Type SSB-T Copper
Single Side Break
Disconnect Switch
15.5-72.5 kV, 1200A



**Southern
States, Inc.**

30 Georgia Avenue
Hampton, Georgia 30228
770-946-4562 Telephone
770-946-8106 Fax

UNPACKING AND INSPECTION

The SSB-T switch consists of: Live parts — blades with hinges, terminal pads and contacts; bases; insulators; interphase and control pipes with hardware; and out-board bearing and operator.

Inspect all switches and parts as soon as they are received. Check against the packing list to be sure all parts have been received. Notify carrier if any parts are damaged or missing.

INTRODUCTION

The Type SSB-T switch is a three-pole, single-throw, two insulator, single rotating stack, side-break, group-operated, outdoor air disconnect switch. The current carrying parts are copper and copper alloy with silver-to-copper current transfer points.

Factory adjustments are carefully made and the switch given mechanical tests after which the adjustments are rechecked. Adjustments may change if insulators are installed after shipment.

Figure 1 and Figure 2 are Typical Single Pole Assemblies.

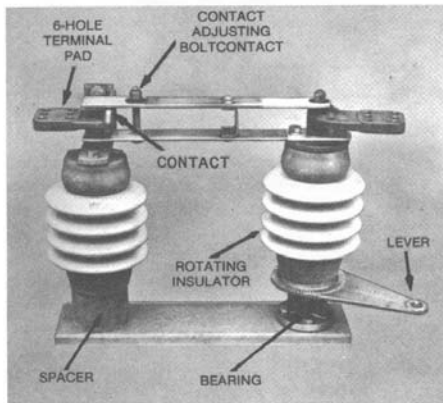

Figure 1 — 15.5 — 38 kV

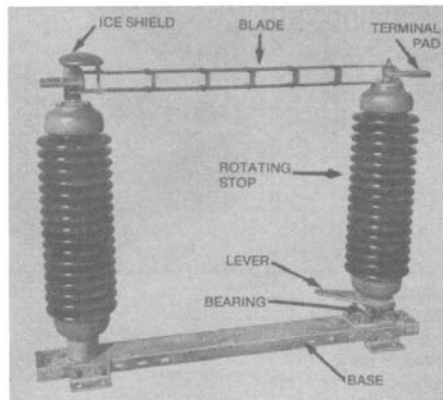

Figure 2 — 48.3 — 72.5 kV

ASSEMBLY AND ADJUSTMENT

- A. When insulators are shipped installed on the switch, proceed to page 3 — *Mounting Switch on Structure*.
- B. Set up bases at ground level on transverse beams (base supports). Make sure the base support beams are level, then secure the switch bases to them so that during adjustment the switch does not tip over. The switch poles in most cases are top heavy and easily tipped over after installing the insulators.
- C. Removal of live parts:
Open the blade and remove the contact end live parts assembly (see Figure 5). Now remove the hinge end live parts assembly (see Figure 4). Rotate the insulator bearing to the fully closed position.
- D. Stack insulators.
Consult your single-pole sub-assembly and control arrangement drawings for proper positioning of levers, spacers, etc. Sort out hardware. Install and plumb the insulators, leaving all bolts finger tight. *Do not tighten.* Wrench tightening of insulator bolts will be done in Part E.
- E. Mount live parts on insulators.
Be sure the rotating insulator bearing (Figure 3) is in the closed position. Mount the hinge end live parts in the closed position (Figure 4). Open the blade and mount the contact end live parts (Figure 5). Live parts on this switch may be handled by one man. *Now tighten all bolts!*

ADJUSTMENT

- A. Adjustment of switch in closed position:
If the blade does not align properly with the contact, improper operation will result. Check to make sure all bolts are tight. Variances in insulators may cause some misalignment, which will require shimming of the insulator to obtain proper alignment. Note: A simpler method would be to apply just enough force at the contact end of the blade, to bend the blade at the hinge, and center the blade on the contact.

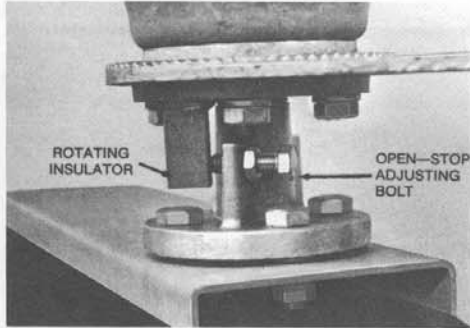

Figure 3 — Rotating insulator bearing.

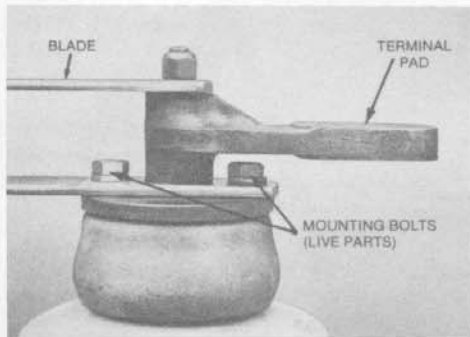

Figure 4 — Hinge end.

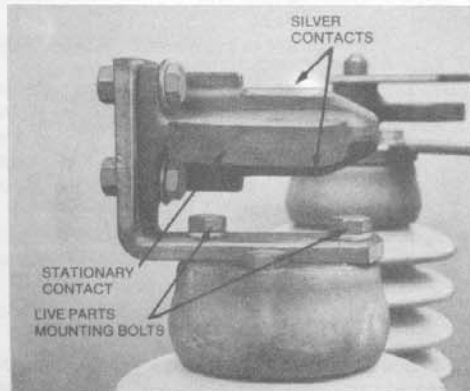

Figure 5 — Contact end — switch open.

B. Adjustment of switch in open position:

Rotate the hinge end insulator stack to the open position. The blade travels 67° from fully open to fully closed (see Figure 7). Check stops on rotating bearing at base of the rotating insulator; be sure these stops have been set to allow the proper angle of rotation (see Figure 3).

C. Adjustment of contact pressure.

The correct contact pressure has been pre-set at the factory and should not need adjustment. If for some reason you find it necessary to adjust the contact pressure, follow these rules:

1. Consult your single-pole assembly drawing for the correct contact pressure at the hinge and contact end.
2. To increase the contact pressure, tighten the contact adjusting bolt (Figure 6). Be cautious about applying too much pressure as it may cause galling of the silver contact surfaces.
3. To decrease the contact pressure, loosen the contact adjusting bolt (Figure 6). Too little pressure on the contact will cause burning and pitting of the silver contacts.

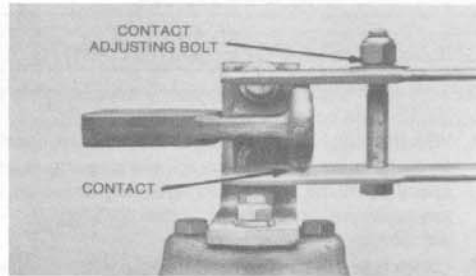

Figure 6 — Contact end shown fully closed.

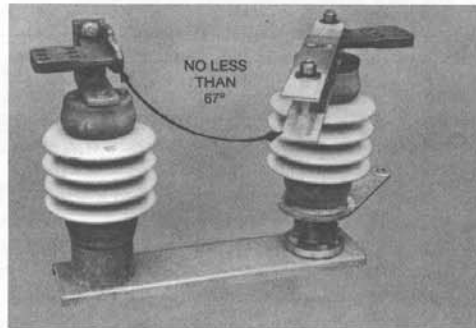

Figure 7 — Blade shown fully open.

ARCING HORN ADJUSTMENT

If arcing horns are supplied and adjustment is required proceed as follows:

- A. Operate switch.
- B. Blade should make light to firm sliding contact along the straight portion of the horn until the switch is fully closed.
- C. Readjustment of the arcing horn can be done by grasping it firmly and bending until the action described above is achieved. See Figure 8.

MOUNTING SWITCH ON STRUCTURE

- A. *Caution:* Rigging used to lift the poles should be attached to the base with steadying guides attached to prevent tipping of the switch pole. *Do not lift the switch by attaching to the live parts.* Lift the switch poles onto the structure, being sure the blade is in the closed position. Refer to the control arrangement drawing for proper placement of the switch on the structure.
- B. Check mounting surfaces for unevenness. Switch bases will warp on uneven surfaces. Use shims under bases to level if necessary.
- C. Bolt bases solidly to the structure.

CHECK SINGLE-POLE ADJUSTMENTS

Be sure each single pole is properly adjusted before connecting the controls and operators.

- A. With the switch bolted solidly to the structure, check to make sure that the single-pole opening is as specified in the single-pole assembly drawing. If readjustment is required, refer to page 1 — *Adjustment*.
- B. Check blade to be sure it meets the contact squarely. If it does not, refer to page 1 — *Adjustment*.
- C. Recheck other adjustments as required.

MAINTENANCE

This switch has been designed to operate with minimum maintenance. However, the following inspections will usually result in a safer and easier operating switch.

- A. Before energizing switch, be sure to follow ANSI/IEEE C37.35 "Guide for the Application, Installation, Operation and Maintenance of High-Voltage Air Disconnecting and Load Interrupter Switches." Pay particular attention to section 5.11 "Inspection."
- B. The switch should be cleaned periodically to remove contaminant particles that have been on the switch.

Cleaning after installation is recommended to remove dirt or other contaminants that have been deposited on the switch during shipment or storage.

- C. Check for loose bolts and nuts; tighten if needed.



Figure 8 — Adjusting arcing horn.

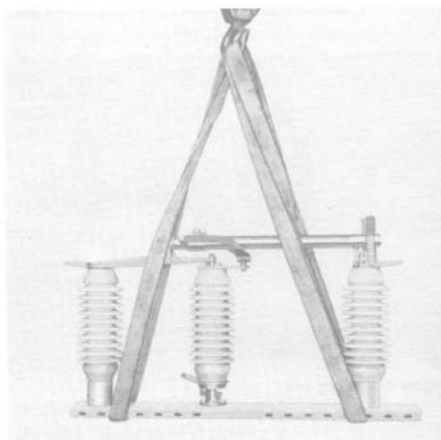

Figure 9 — Switch pole ready to lift.

- D. Examine the contact surfaces.
 1. Switches are shipped with the contact surfaces coated with a conductive contact lubricant to prevent contact damage during transit. Although the contacts are designed to operate dry, switch operating effort may be reduced with the use of a contact lubricant.
 2. If damage has occurred from pitting or wear, replace the damaged parts with Southern States replacement parts.
- E. Examine the switch for blade contact alignment and realign, if necessary.
- F. Check all galvanized surfaces for chips. If chipping has occurred, use "Galvanox"SM or equivalent as a touchup.

Operating Mechanism Installation

MANUAL AND MOTOR OPERATED

These switches are designed to be opened and closed as a three-phase unit by a system of pipes that translates the rotation movement of an operator on the ground — whether manual or motor — to simultaneous rotation of the end insulator of each switch pole. Figure 1 shows alternate operating mechanism designs, each of which is employed as being the simplest arrangement for a given structure. In all cases, however, the operating principle remains the same, and the methods of installation and adjustment are virtually identical.

Refer to the Operating Mechanism Drawing provided with your switch and follow these steps:

1. Have all switch poles completely closed. Install all components shown on the Operating Mechanism Drawing, including interphase pipe, vertical pipe, all brackets, bushings, etc., and the adjustable crank arm.

IMPORTANT: The weight of the vertical pipe must be entirely supported by the pipe collar above the vertical bearing. The housing of neither the manual gear operator nor the motor operator was designed to support this weight. Additionally, if the vertical pipe is not suspended at the dimension shown, the decoupler mechanism will jam.

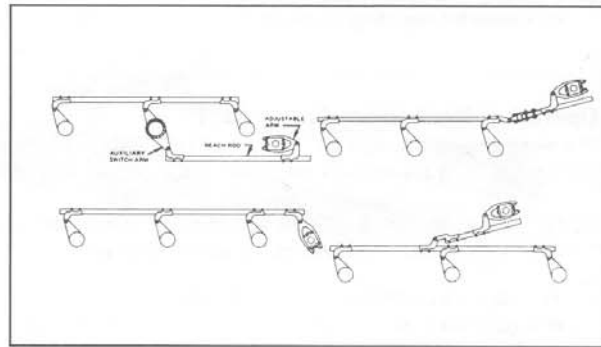

Figure 1. For this type, set adjustable arm parallel to switch arms.

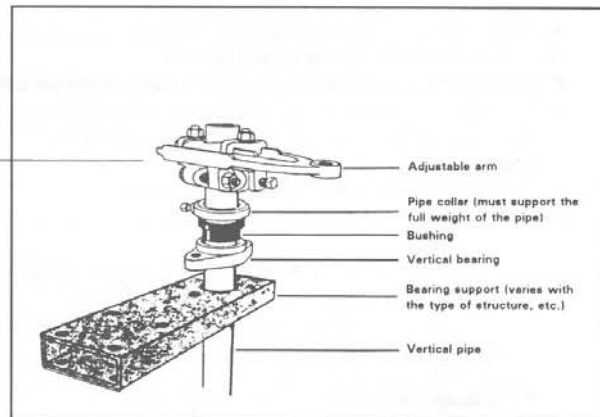

Figure 2.

General Installation Note:

When a switch uses an auxiliary switch arm, installation will be easier if this pole is adjusted before installing the interphase pipe. This will eliminate trying to coordinate and adjust all three poles at once.

General Installation Note:

1. If the components have self-piercing set screws, during installation tighten them to only grip the pipe (*match mark to check for slip-page*) and drive them in only after adjustments are completed.
2. If a motor operator is used, at this point refer to its installation instructions for mounting, checkout procedure and trial operations.

Operating Mechanism Adjustment

(If a motor operator is used, DO NOT USE ELECTRICAL OPERATION until the following adjustments are completed.)

NOTE: The setting of the adjustable arm on the Operating Mechanism Drawing is a calculated dimension. **To adjust precisely:**

1. The adjustable arm should travel 180 degrees from toggle closed to toggle open. (*Exceptions may occur. Refer to the Operating Mechanism Drawing.*) Manually test operate.
2. If the switch does not fully open, the radius of the arm is too short.
To correct:
 - A. Check first to see that nothing has slipped.
 - B. Return the switch to the closed position.
 - C. Loosen the adjustable arm and clevis bolts as shown below.
 - D. Lengthen the radius of the adjustable arm about 1/4 inch and allow the clevis to reposition itself the same distance (*shortening the pipe*).
 - E. Test operate again and adjust as necessary.

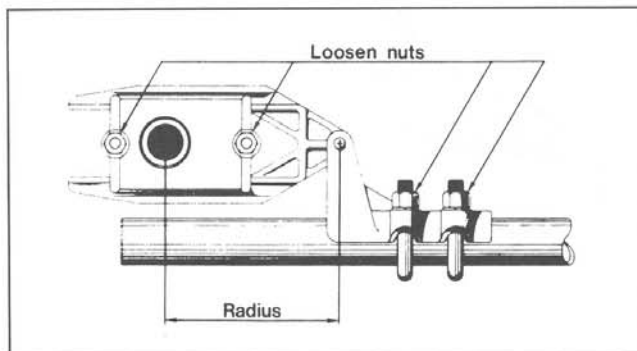

Figure 3.

3. If the switch is fully open before the control handle reaches the open position, the radius of the adjustable arm is too long. **To correct:**

- A. Check to see that nothing has slipped.
- B. Return the switch to the closed position.
- C. Loosen the adjustable arm and clevis bolts as shown above.
- D. Shorten the radius of the adjustable arm about 1/4 inch and allow the clevis to reposition itself (*lengthening the pipe*).
- E. Test operate again and adjust as necessary.

All poles of the fully adjusted switch should operate simultaneously. Slight adjustment of the interphase clevises may be necessary to coordinate all three poles.

4. When the switch is completely adjusted, securely tighten all bolts, and tighten all set screws until the pipe walls are pierced. (*For heavy wall pipe, drill the set screw holes, using the threaded drill guides supplied and a 1/4" drill.*)



General instructions for threaded clevises

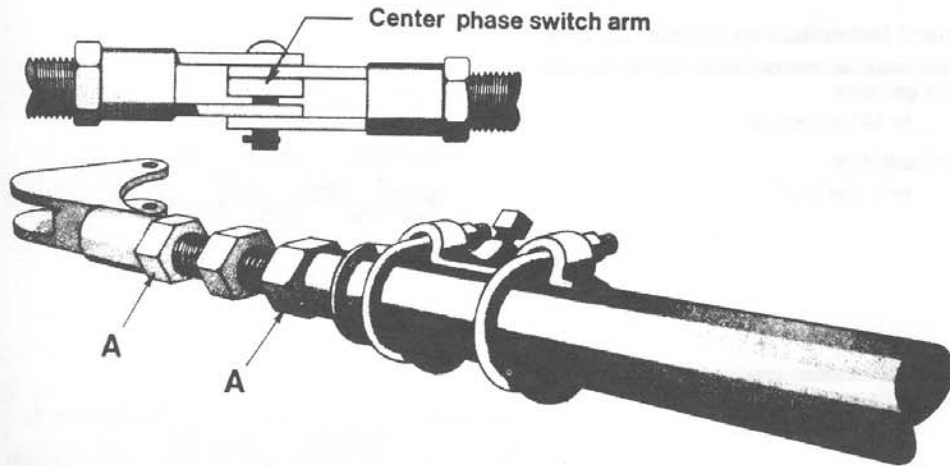

When threaded clevises are specified, one is generally attached to the adjustable arm, and two more to the center phase switch arm. (Refer to the plan view of the operating mechanism drawing, and the illustration above.)

Operating mechanism adjustments consist mainly of incremental lengthening and/or shortenings of the pipes that connect the switch arms together. To make these adjustments, simply loosen both jam nuts "A" and screw the stud in or out as required. Be sure to retighten both jam nuts securely.

CAUTION! DANGER:

DO NOT SCREW THE STUD OUT OF THE CLEVISES.

This could cause the pipe to fall, resulting in serious injury to personnel below. Be sure the initial setting is correct, and do not adjust beyond the maximum allowable dimension. If adjustment beyond the maximum allowable dimension is needed, loosen the U-bolts on the outboard phase clevis and reposition the pipe toward the center phase.

General instructions for threaded clevises

INITIAL DIMENSION:

...for 3/4" stud is 11/16"

INITIAL DIMENSION:

...for 1" stud is 1/2"

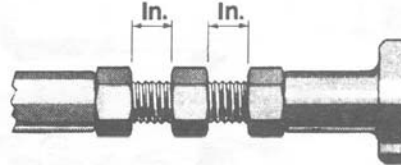

MAXIMUM ALLOWABLE

...for 3/4" stud is 1-3/16"

MAXIMUM ALLOWABLE

...for 1" stud is 1"

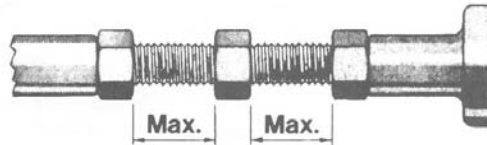

CAUTION! DANGER:

DO NOT SCREW THE STUD OUT OF THE CLEVISES.

This could cause the pipe to fall, resulting in serious injury to personnel below. Be sure the initial setting is correct, and do not adjust beyond the maximum allowable dimension. If adjustment beyond the maximum allowable dimension is needed, loosen the U-bolts on the outboard phase clevis and reposition the pipe toward the center phase.



The Quality Name in High Voltage Switching

30 Georgia Avenue
Hampton, Georgia 30228
Phone: 770-946-4562
Fax: 770-946-8106
E-mail: support@southernstatesllc.com
<http://www.southernstatesllc.com>

©2015 Southern States, LLC
IB-122-SSB-T 72.5-Rev 1 100815 Printed U.S.A.