



The Quality Name in High Voltage Switching

## **Type RDA – RDA-1**

Aluminum Double End  
Break Disconnect  
Switch

**Volt: 345kV**

**Amp: All**

**INSTALLATION &**

**INSTRUCTION**

**MANUAL**



## Safety Information

### DANGER

IMPROPER HANDLING, INSTALLATION, OPERATION OR MAINTENANCE OF THIS EQUIPMENT MAY CAUSE IMMEDIATE HAZARDS WHICH WILL LIKELY RESULT IN SERIOUS PERSONNEL INJURY OR DEATH.

### WARNING

The equipment covered by this publication must be handled, installed, operated and maintained by qualified persons who understand any hazards involved and are thoroughly trained in the handling, installation, operation and maintenance of high voltage transmission and distribution equipment. These instructions are meant for only such **Qualified Persons**. They are not intended to be a substitute for adequate training and experience in safety procedures for this type of equipment.

A **Qualified Person** is one who is trained in and has skills necessary:

- to read and comprehend this instruction book – understanding that these instructions are general in nature
- to accept personal responsibility to prepare and maintain an intrinsically safe work environment and maintain control of the work site to safeguard all persons present
- to develop and implement a proper rigging, lifting, and installation plan along with all safety precautions required to insure safe and proper lifting and installation of the equipment.
- to distinguish between energized and non energized parts
- to determine proper approach distances to energized parts
- to properly work with and around energized or de-energized equipment that may be pressurized with gas
- for proper use of personal protective equipment, insulating and shielding materials, insulated tools for working near energized and /or pressurized electrical equipment
- to recognize and take necessary precautions for the unique and dynamic conditions of site and specialized equipment to maintain a safe work environment during handling, installation, operation, and maintenance of high voltage switching equipment

The instructions in this manual are general guidelines for this type of equipment and not specific to the equipment supplied. Portions of it may not be applicable or may not have complete instructions for your specific equipment.

If you do not understand any part of these instructions or need assistance, contact Southern States Service Division at 770-946-4562 during normal business hours (8:00am – 4:30pm EST, M-F) or 770-946-4565 after normal business hours.

## LIMITED WARRANTY

Southern States, LLC (“SLLC”) warrants only to the Warranty Holder (hereinafter defined as the “End User” or the “Immediate Purchaser”, as applicable, pursuant to the terms and conditions of this Limited Warranty as set forth below), that the Product identified below will, upon shipment, be free of defects in workmanship and material for the applicable Warranty Period. The “Warranty Period” is that period of time during which this Limited Warranty is effective, and such period begins on the invoice date issued by SLLC for the Product, and continues until the earlier to occur of (1) the expiration of the Warranty Duration period, or (2) the Number of Operations, both as specified in the table below. If the Product is both purchased and installed within the United States or Canada, this Limited Warranty is granted to each end user of the Product who acquired the Product for its own use during the Warranty Period (“End User”). In all other situations, this Limited Warranty is granted only to the first purchaser of the Product (“Immediate Purchaser”) from SLLC. No primary or remote purchaser or owner of the Product who is not a Warranty Holder may claim any benefit under this Limited Warranty, or any remedial promise included in this Limited Warranty. SLLC shall, upon prompt written notice from the Warranty Holder, correct a nonconforming Product by repair or replacement at the sole discretion of SLLC of the nonconforming Product or any part or component of a nonconforming Product necessary in SLLC’s discretion to make such Product conforming. Any transportation charges, labor for removing, reinstalling the Product or part, and/or costs related to providing access to the Product shall be the responsibility of the Warranty Holder. Correction in this manner will constitute the Warranty Holder’s exclusive remedy and fulfillment of all SLLC’s liabilities and responsibilities hereunder. SLLC’s duty to perform under this limited warranty may be delayed, at SLLC’s sole option, until SLLC has been paid in full for all products purchased by the Warranty Holder. No such delay will extend the Warranty Period. If SLLC does not make such repair or replacement, SLLC’s liability for damages on account of any claimed nonconformity will in no event exceed the purchase price of the Product in question. This Limited Warranty does not apply to any Product that has been disassembled, repaired, or altered by anyone other than SLLC. This Limited Warranty will not apply to any Product that has been subjected to improper or abnormal use of the Product. SLLC has no responsibility to repair or replace any Product or component thereof manufactured by another party, but SLLC will assign, to the extent assignable, to the Warranty Holder any manufacturers’ warranty that applies to products and components not manufactured by SLLC.

**THIS LIMITED WARRANTY IS EXCLUSIVE AND IN LIEU OF ALL OTHER WARRANTIES. THERE ARE NO OTHER EXPRESS, IMPLIED, OR STATUTORY WARRANTIES. ALL IMPLIED WARRANTIES WHICH MAY ARISE BY IMPLICATION OF LAW, OR APPLICATION OF COURSE OF DEALING OR USAGE OF TRADE, INCLUDING, BUT NOT LIMITED TO, IMPLIED WARRANTIES OF MERCHANTABILITY OR FITNESS FOR A PARTICULAR PURPOSE, NONINFRINGEMENT OR OTHERWISE ARE EXPRESSLY EXCLUDED. SLLC SHALL NOT BE LIABLE OR RESPONSIBLE FOR ANY CONSEQUENTIAL, INCIDENTAL, INDIRECT, EXEMPLARY, SPECIAL, OR PUNITIVE DAMAGES, EVEN IF SLLC HAS BEEN ADVISED OF THE POSSIBILITY OF SAME. THE WARRANTY HOLDER IS SOLELY RESPONSIBLE FOR THE SUITABILITY OF THE PRODUCT FOR ANY PARTICULAR APPLICATION.**

Product Purchased Region	Product Installed Region	Warranty Holder	Warranty Duration
U.S and Canada	U.S and Canada	End User	5 Years
All Other Conditions		Immediate Purchaser	Earlier of 1 year from installation or 18 months from shipment

Revised 7/14/15

**Type RDA & RDA-1**  
Aluminum Double End Break  
3-Phase, Group Operated  
Disconnect Switch  
**Volt: 345kV**  
**Amp: All**





---

## Table of Contents

---

Table of Contents .....	VI
List of Tables and Figures.....	VII
Summary & Introduction .....	1
Summary .....	1
Important .....	1
Introduction.....	2
Recommended Tools & Values .....	3
Product Description.....	4
Typical Disconnect Switch.....	4
Installation & Adjustment Procedures .....	5
Assembly .....	5
Proper Contact Engagement.....	10
Contact Misalignments and Corrective Procedures .....	12
Mounting and Final Adjustment.....	15
Operating Mechanism .....	17
Recommended Inspection Maintenance.....	20
General Instructions for Threaded Clevises .....	21

---

## List of Tables and Figures

---

### **Tables** **Page**

---

Table 1: Recommended Tools and Torque Values .....	3
--	---

### **Figures** **Page**

---

Figure 1: Identification of parts (no scale) RDA 345kV, 2,000 amp shown .....	4
Figure 2: Match mark locations .....	5
Figure 3: Spacers (“A”) are mounted above the corona shields (“B”) to maintain equal height of live parts when live part accessories are used. Otherwise, no spacers are supplied.....	6
Figure 4: Jack Screw Adjustment .....	7
Figure 5: Find and mark exact center of rotating insulator. ....	7
Figure 6: Adjusting the rotating insulator for concentric rotation .....	8
Figure 7: Timesaving Tip .....	9
Figure 8: Mounting Switch .....	10
Figure 9: The switch blade should hit both stops “A” and “B” simultaneously.....	10
Figure 10: The blade tips must be centered in the contact fingers.....	11
Figure 11: Blade rotation.....	11
Figure 12: Blade tip attempts to move up or down during final blade rotation. Recheck rotating insulator adjustments.....	12
Figure 13: Blade misalignment requiring bearing adjustment. ....	12
Figure 14: Blade striking one jaw ahead of the other. ....	12
Figure 15: Tap the lower bearing housing in the same direction the insulator is leaning. For example, in Figure 13 in which the stack is leaning toward the left side of the picture, tap the housing in that direction to tilt the stack back to perpendicular, which is to the right of its present centerline.....	13
Figure 16: Adjust jaw up or down so that leading edge of blade tip touches the contact fingers first. ....	14
Figure 17: Sling attachment .....	15
Figure 18: Arcing horn attachment. Blade arcing horn (arrow) goes under jaw horn.....	16
Figure 19: Correct arcing horn adjustment has horn parallel to movement of the blade tip, allowing light contact through full length of engagement. ....	16
Figure 20: Improper adjustment allows arcing horn to droop into blade path. <i>Could cause switch malfunction.</i> .....	16
Figure 21: Schematic drawing of a typical interphase pipe arrangement with the auxiliary switch arm at “A”..	17
Figure 22: Adjustable arm assembly.....	18
Figure 23: Adjustable arm .....	18

## Summary & Introduction

### Summary

These instructions do not intend to cover all details or variations in equipment, or provide for every possible contingency to be met in connection with installation, operation or maintenance. Should information be desired or should particular problems arise which are not covered sufficiently for the purchaser's purposes, the matter should be referred to the local Southern States Representative.

The contents of this instruction manual should not become part of or modify any prior or existing agreement, commitment or relationship. The sales contract contains the entire obligations of Southern States. The Warranty contained in the contract between the parties is the sole warranty of Southern States. Any statements contained herein do not create new warranties or modify the existing warranty.

### Important

The information contained herein is general in nature and not intended for specific application purposes. It does not relieve the user of responsibility to use sound practices in application, installation, operation, and maintenance of the equipment purchased. Southern States reserves the right to make changes in the specifications shown herein or to make improvements at any time without notice or obligations. Should a conflict arise between the general information contained in this publication and the contents of drawings or supplementary material, or both, the latter shall take precedence.

## Summary & Introduction

### Introduction

Southern States switches designated RDA and RDA-1 that are rated 345kV come in current ratings of 1600, 2000, and 3000 continuous amperes. The illustration below shows the basic design configuration of these switch lines; however, individual differences may exist between models due to different mounting schemes, insulator types and sizes, and customer requirements. But regardless of their appearance, all RDA and RDA-1 switches share basic mechanical details, and the installation procedure is the same for all.

Since these switches are normally shipped without insulators, installation consists of removing the live parts from the base, mounting the base on the structure, mounting the insulators to the base, and mounting the live parts to the insulator.

These switches may be assembled on the structure, or assembled on the ground and hoisted to structure according to preference. When assembling switches on the ground, be sure the base rests on a firm, level surface. Metal sawhorses, or their equivalent, may have to be constructed for this purpose.

When hoisting switches, LIFT BY THE SWITCH BASE ONLY.

Before mounting the switches on the structure, refer to the Operating Mechanism drawing because there may be differences in the switch poles that require that they be mounted in specific locations.

Do not change any factory setting on the switch unless directed to in this manual.

All photographs and sketches in this manual are for illustration purposes only and may not be to scale. Refer to the Unit Assembly drawing or the Operating Mechanism drawing provided with each disconnect switch for specific details. During installation, it may be necessary to make adjustments other than those described in this manual. Contact your local representative or the factory if questions should arise.

Southern States After Sales and Service Department is available for field installation assistance along with providing parts support for all Southern States products.

Contact After Sales and Service at 770-946-4562.

**⚠ DANGER**

Indicates an imminently hazardous situation, which, if not avoided, will result in death or serious injury.

**⚠ WARNING**

Indicates a potentially hazardous situation, which, if not avoided, could result in death or serious injury.

**⚠ CAUTION**

Indicates a potentially hazardous situation, which, if not avoided, may result in minor or moderate injury. It may also be used to alert against unsafe practices.

## Recommended Tools & Values

**Table 1: Recommended Tools and Torque Values**

Recommended Tools		Recommended Torque Values	
Type	Sizes	Bolt/Nut size	Torque (Ft-lb)
Hand Wrenches and/or Sockets	15/16", 3/4", 5/8", 9/16"	1/2"	40
Drill Bit	1/4"	5/8"	92
		3/4"	127
		1"	286

Product Description

Typical Disconnect Switch

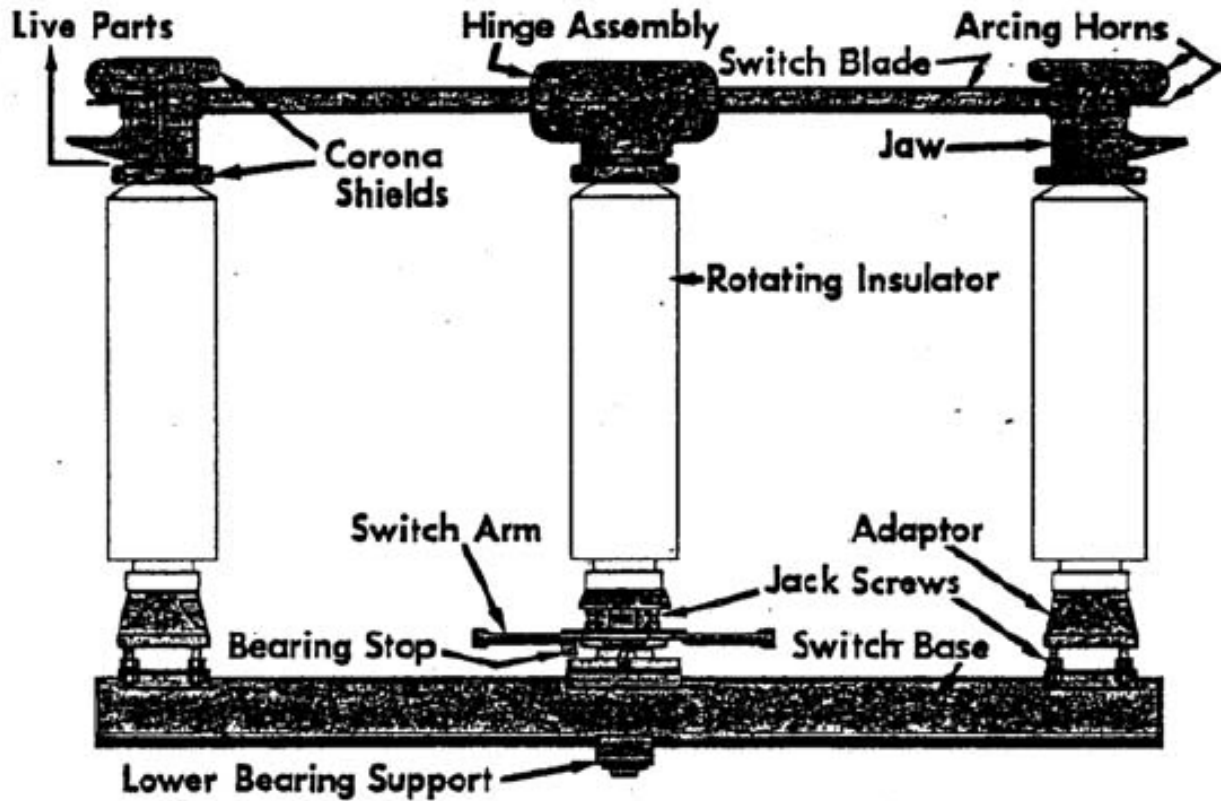


Figure 1: Identification of parts (no scale) RDA 345kV, 2,000 amp shown

## Installation & Adjustment Procedures

### Assembly

The general procedure for installing these switches is as follows:

1. Uncrate the switches, remove the shipping ties, and check for damage in transit. If any damage is found, immediately file a claim with the carrier and notify the factory.
2. Using any convenient means, match mark the lower parts of the hinge assembly with the switch arm and the rotating hub to ensure correct re-assembly as shown in Figure 2. Also match mark one blade tip with its jaw.

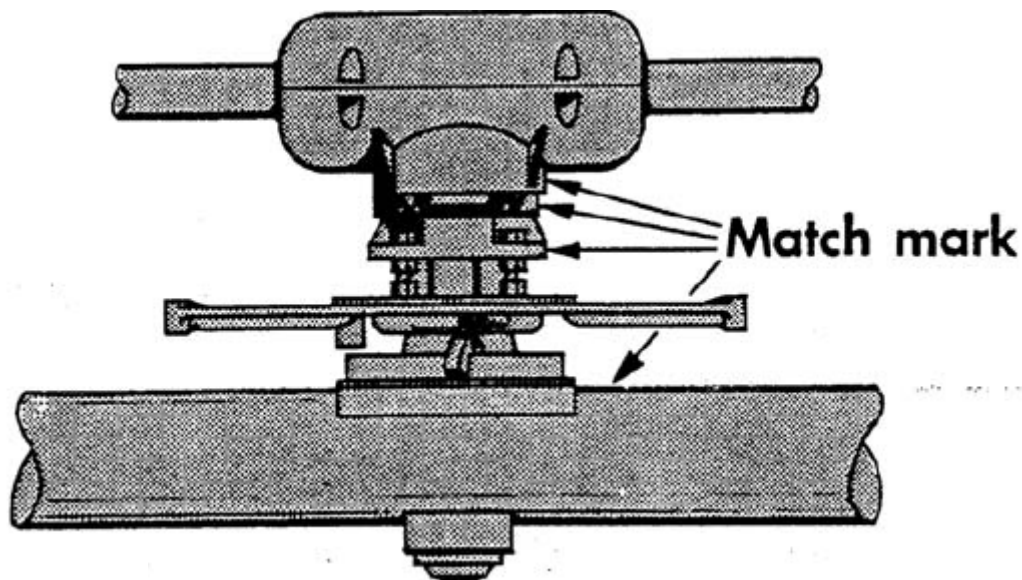
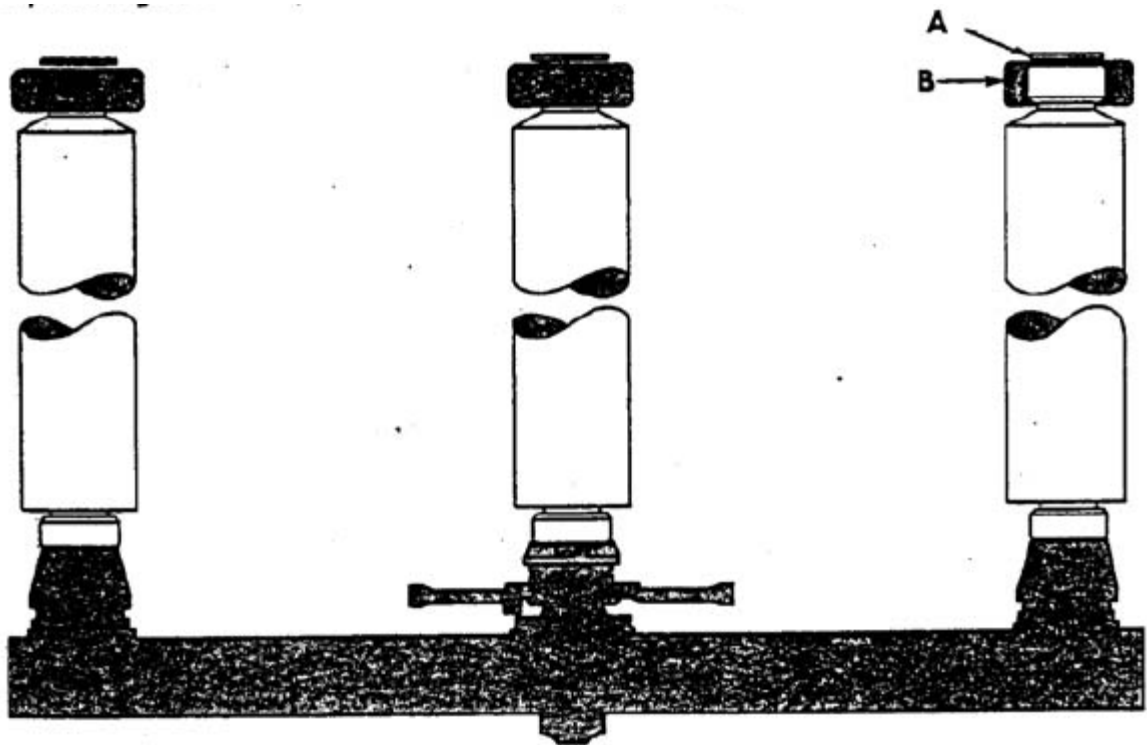


Figure 2: Match mark locations

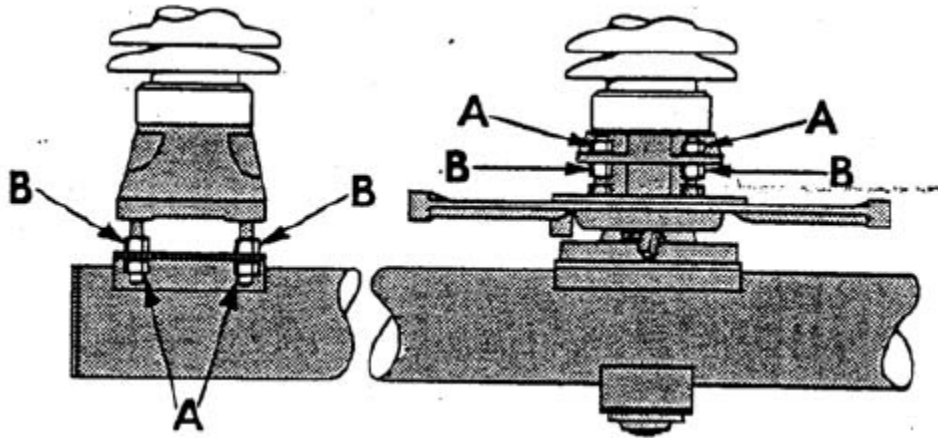
3. Rotate the switch arm to relieve the contact pressure on the switch blade. Remove the live parts from the adaptors and save the bolts for re-use (IF they are of a type specified on the Unit Assembly Drawing for insulator mounting – galvanized, stainless steel, or bronze).  
*NOTE: Some poles may have an auxiliary switch arm. Check the Op. Mech. Drawing for proper adjustment of this arm.*
4. Mount the insulators as indicated in Figure 3, using the bolts specified in the field assembly bolt list (SF Drawing). Be sure that the match marks made earlier line up. Place the corona shields as indicated in Figure 3. If the switch is equipped with a grounding switch jaw or outriggers, spacers will have to be used to maintain equal height of live parts. Refer to the Operating Mechanism Drawing.



**Figure 3: Spacers (“A”) are mounted above the corona shields (“B”) to maintain equal height of live parts when live part accessories are used. Otherwise, no spacers are supplied.**

5. Use a plumb bob or level and true up the end insulators. It is important that they be perpendicular to the base in both planes. Use the jack screws to level these stacks. (Due to the overhang of the insulator skirts, it will be necessary to use a piece of scrap metal or wood to extend the plumb bob string beyond the skirts). See Figure 4 for jack screw adjustments procedure.

Adjustment to these switches mainly concern getting the insulator stacks properly aligned. This is done with the jack screws that support the adaptors to which the insulators are bolted. The best procedure to do this is described below.



**Figure 4: Jack Screw Adjustment**

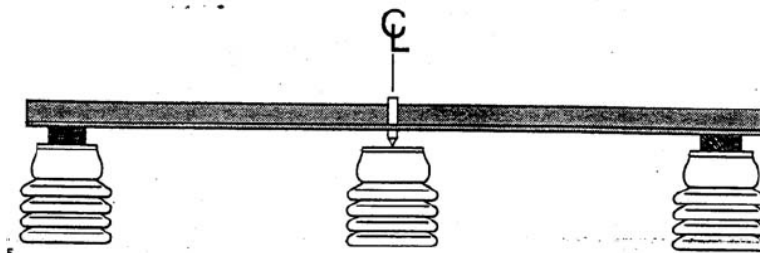
- To adjust the insulator stack, first loosen all four nuts (A). Tilt the insulator to the required position by screwing up or down on nuts (B). Re-tighten nuts (A).
6. The rotating insulator requires special attention to ensure good switch operation. It is necessary that this stack rotate about its axis uniformly; that is, it must not “wobble” as it rotates. However, due to irregularities in the mounting faces of individual insulator units, it is not unusual for an insulator stack to be out of alignment six inches or more. And while this switch is designed to tolerate a certain amount of misalignment, the rotating insulator should be adjusted so that evident “wobble” is  $\frac{1}{4}$  inch or less. The best procedure to achieve this is described on the following page.



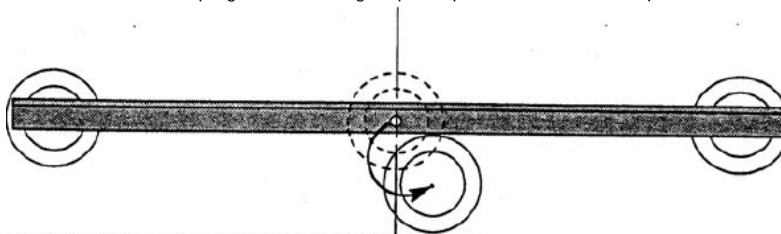
**Figure 5: Find and mark exact center of rotating insulator.**

Preparation

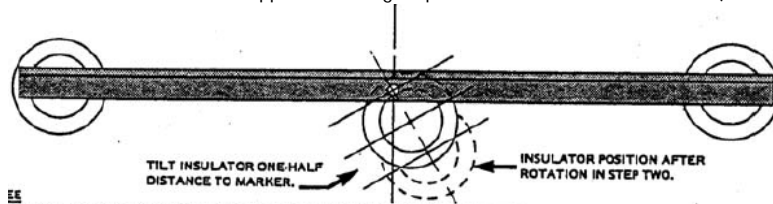
- A. Place a mark on the exact center of the rotating insulator
- B. Make a marker of any convenient material such as metal angle or lumber.
- C. Make a sharp pointer and attach it to the center of the marker. Place the marker over the center of the rotating insulator in such a manner that it can be used as a reference point but does not drag on the insulator top during rotation. Blocks of wood, etc., can be used on the ends to compensate for sag. The marker should be free to be repositioned, as described below.



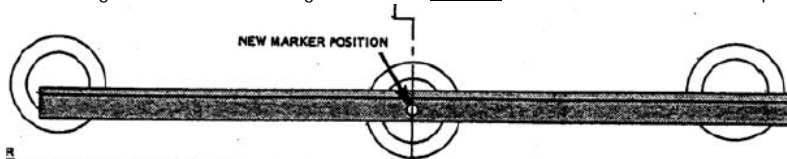
Step One – Rotate the insulator up against a bearing stop and position the reference point over the center of the insulator top.



Step Two – Rotate the insulator to the opposite bearing stop. Observe for eccentric rotation (“wobble”).



Step Three – If during rotation the insulator has wobbled. Leave it against the bearing stop in step two. Use the jack screws that mount the rotating insulator to the bearing to tilt it back one-half the distance to the reference point on the marker.



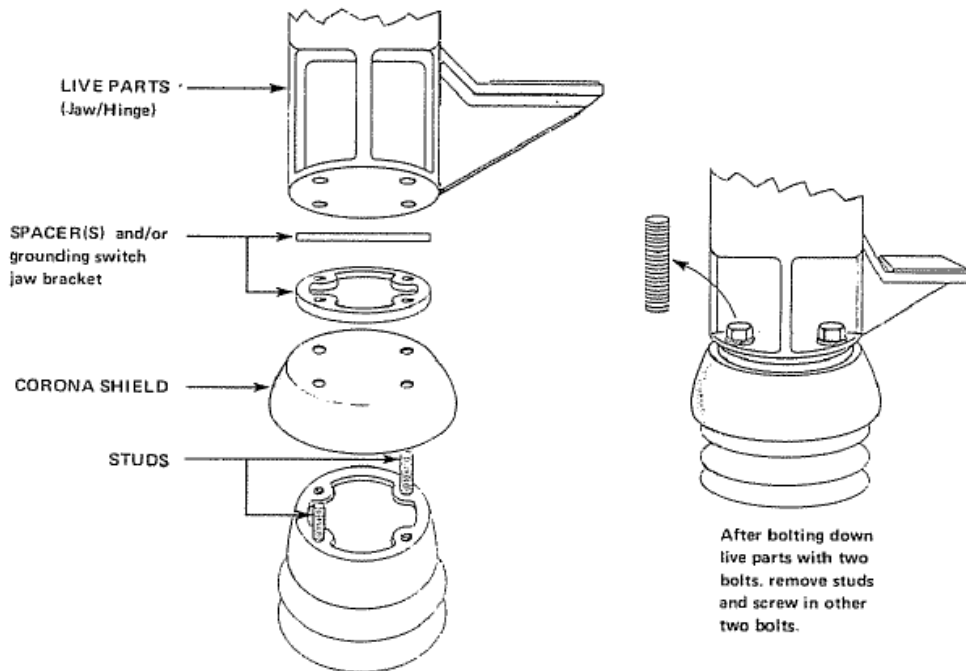
Step Four – Rotate the insulator back to the beginning position (Step One). Reposition the reference point over the center of the insulator. Repeat the last three steps until the insulator rotates true.

This method works whether the rotating insulator is out of adjustment axially, laterally, or any combination in between.

Once the center insulator rotates true, do not disturb the settings of its jack screws. Any further adjustments will be made with the jaw insulator jack screws.

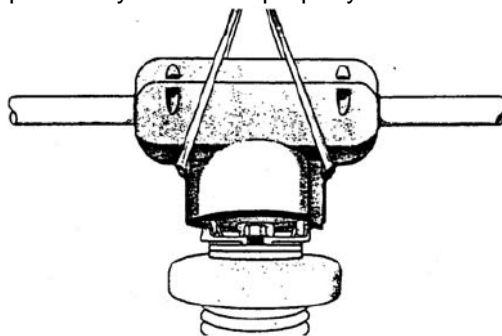
**Figure 6: Adjusting the rotating insulator for concentric rotation**

**TIMESAVING TIP** for mounting live parts when hardware must be placed between the insulator and the live parts: Use two studs of sufficient length to allow later removal (easily made by cutting the heads off two bolts) to align the parts. Bolt the live parts down with mounting bolts, using the two free holes; then remove the studs and screw in the other two bolts.



This procedure can cut a significant amount of time from installation, and will work in all cases except on the center insulator of the double-side-break RDA, RDA-1, and RDC switches.

Where alignment difficulties are encountered with the center stack on double side break switches, match mark and remove the top insulator unit (after adjustment for concentric rotation) and bolt the parts together on the ground, where alignment will be easier. The hoist the blade mechanism assembly and top insulator section into position as an assembled unit and reattach the insulator sections. This will eliminate having to align three non-captive parts in the air. However, if this procedure is used, be sure to match mark the top insulator unit with the next lower unit before removal in order to preserve the concentric rotation adjustments previously made and properly orient the live parts.



**Figure 7: Timesaving Tip**

## Installation & Adjustment Procedures

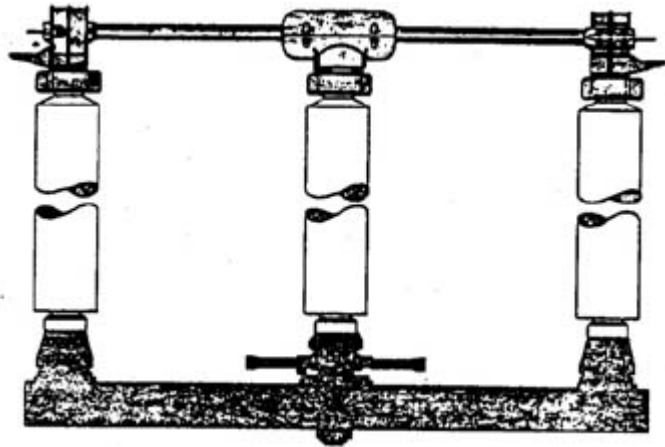
- Mount the hinge and blade assembly as shown in Figure 8. Be sure that the match marks made earlier are aligned. The jaws also may be mounted at this time.

*Note: If applicable, at this time also mount accessories such as: grounding switch jaw, quick break devise, outriggers, etc., as shown on the Op. Mech. Drawing. Use the spacers supplied to maintain equal height of the live parts on the rotating and stationary insulators.*

**Figure 8: Mounting Switch**

FIRST make sure the match marks made earlier are aligned.

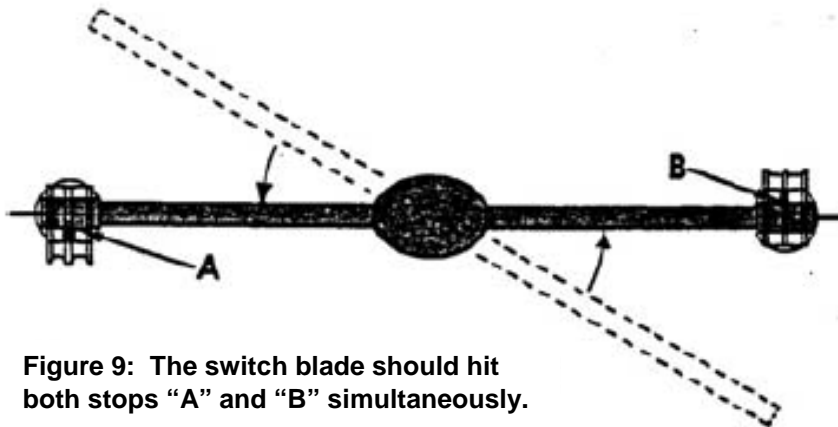
Then mount the blade assembly. Again, make sure the match marks made earlier are aligned.



## Proper Contact Engagement

Carefully close the switch, checking for proper contact engagement described below.

*NOTE: Final adjustment usually cannot be made to these switches until the conductors are attached. Therefore, the conductors should be bolted on before proceeding further. If this is not possible, be sure to recheck the contact engagements described in A through D below after the conductors are ties on and before energizing the switch.*



**Figure 9: The switch blade should hit both stops "A" and "B" simultaneously.**

Installation & Adjustment Procedures

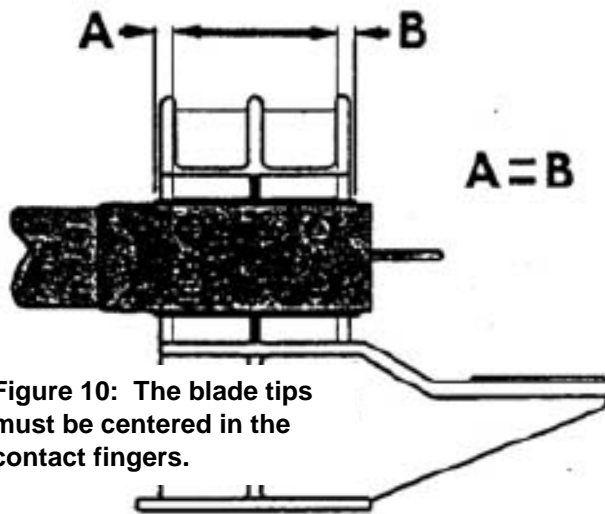


Figure 10: The blade tips must be centered in the contact fingers.

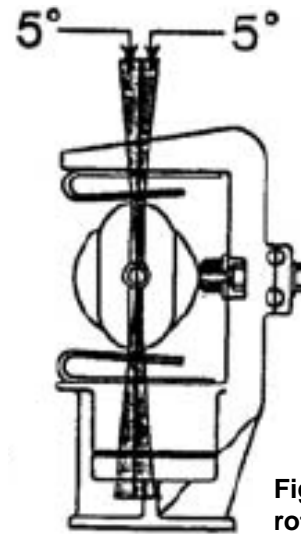


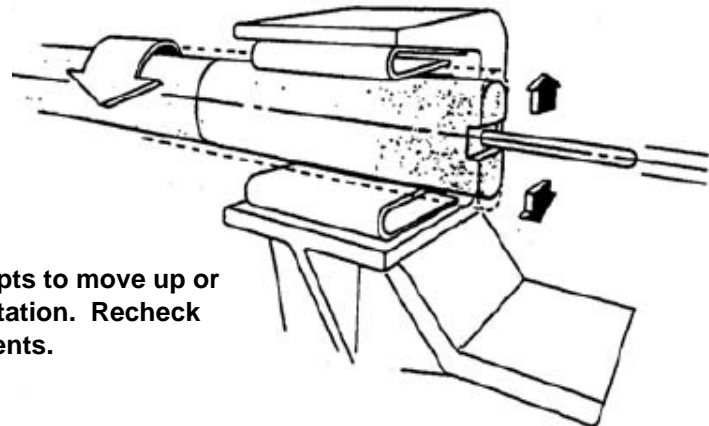
Figure 11: Blade rotation.

- A. The blade tips must hit the stop in the jaws simultaneously (Figure 9). Minor misalignments can be corrected by tilting the jaw insulator stacks with the jack screws.
- B. The blade tips should enter the jaws centrally, without dragging on either contact surface (Figure 10). Minor misalignments can be corrected by jacking the jaw up or down with the jack screws.
- C. The silver of the blade tips should be centered on the silver of the jaw contacts (figure 11). Minor misalignments can be corrected by tilting the jaws toward or away from the center stack, using the jaw jack screws.
- D. Although the switch is fully closed and will have adequate contact pressure if the blade has rotated to within plus or minus 5° or perpendicular in the contacts, every effort should be made to get the tips as nearly vertical in the contacts as possible. Adjust the bearing stops as required.

If the above conditions A, B, or C cannot be achieved with minor adjustments to the jaw insulator jack screws, it will be necessary to make adjustments to the rotating insulator bearing described on the following pages.

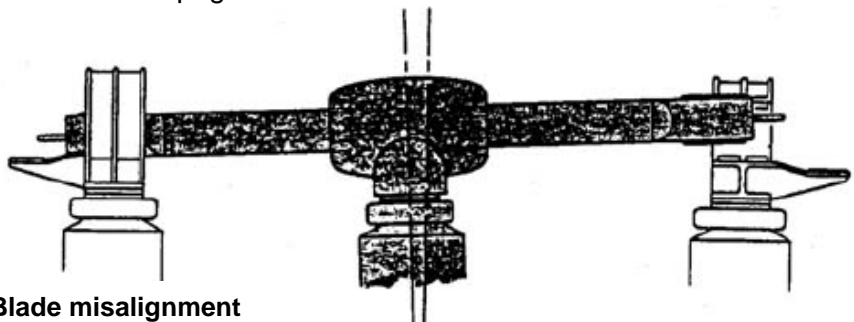
## Contact Misalignments and Corrective Procedures

- A. Blade tip moves, or attempts to move, vertically, during final rotation in contacts.  
Corrective Procedure: The center insulator is not rotating true. Recheck adjustments described in Figure 5.



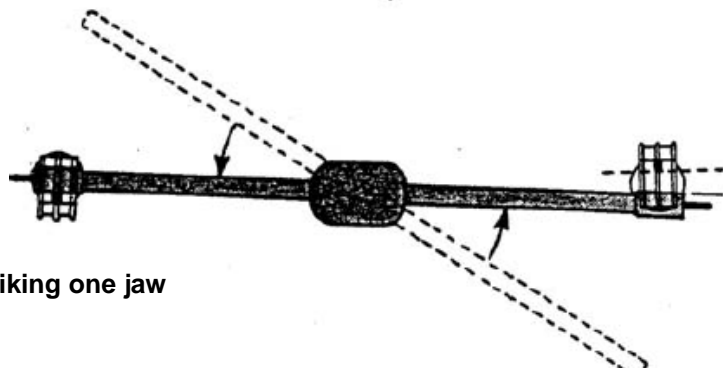
**Figure 12: Blade tip attempts to move up or down during final blade rotation. Recheck rotating insulator adjustments.**

- B. Blade tip high and short on one jaw, low and long on the other.  
Corrective Procedure: See next page.



**Figure 13: Blade misalignment requiring bearing adjustment.**

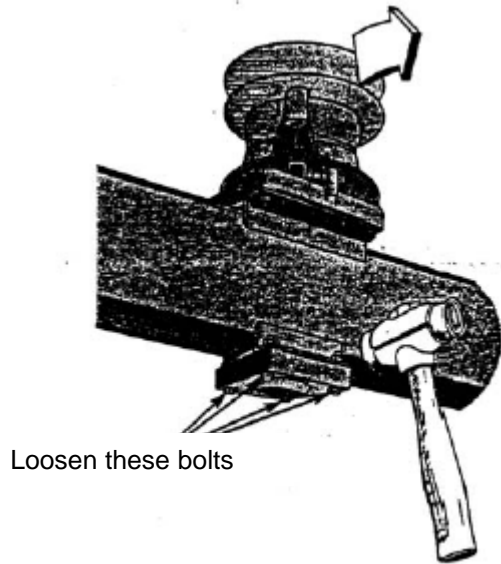
- C. One blade tip striking one jaw ahead of the other.  
Corrective Procedure: See next page.



**Figure 14: Blade striking one jaw ahead of the other.**

## Installation &amp; Adjustment Procedures

- **Corrective Procedure for Misalignments “B” and “C” on previous page:**  
If either condition “B” or “C” is encountered, and if it is certain that both jaw insulator stacks are properly plumbed, it will be necessary to adjust the rotating insulator bearing. This is done as follows:
  - Place the switch in an “almost-closed” position and loosen the lower bearing housing bolts as shown.



**Figure 15:** Tap the lower bearing housing in the same direction the insulator is leaning. For example, in Figure 13 in which the stack is leaning toward the left side of the picture, tap the housing in that direction to tilt the stack back to perpendicular, which is to the right of its present centerline.

Use a non-metallic mallet (rawhide or similar) to tap the lower housing until the blade tips are horizontal in the jaws. *NOTE: Due to the height of the stack, very little movement of the bearing housing produces considerable movement of the blade tips.*

Do not use excessive muscle when making this adjustment. Tap the housing only with enough force to produce incremental movements of the insulator stack. The lower bearing housing is case aluminum, which is very strong but can break if struck too hard.

Be sure to tighten the bearing housing bolts securely.

- D. Blade tip enters jaw, but “walks out” when rotating to vertical in contacts.  
Corrective Procedure: First, recheck the rotating insulator to make sure it is rotating true (see Figure 6). If concentric rotation is verified but the blade tip still walks out, use the jack screws on the base of the affected jaw stack to adjust the height of the jaw so that the leading edge of the blade tip touches the contact fingers first. This will establish a “Bite-in” action that will assist proper contact seating. However, do not allow the blade to drag across the jaw contacts during entry.

Installation & Adjustment Procedures

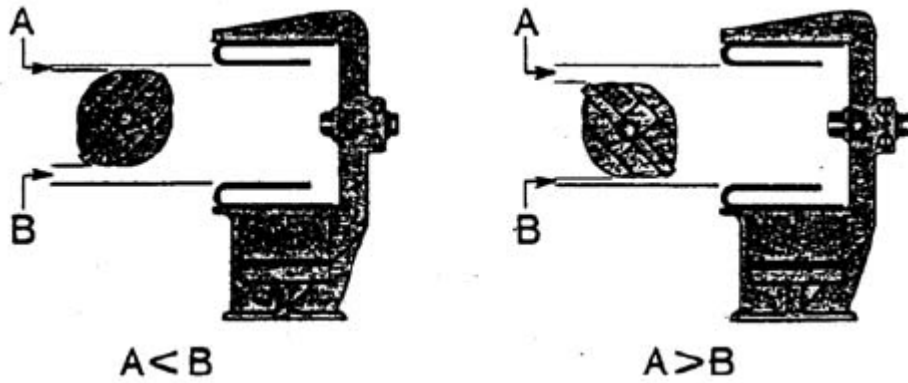
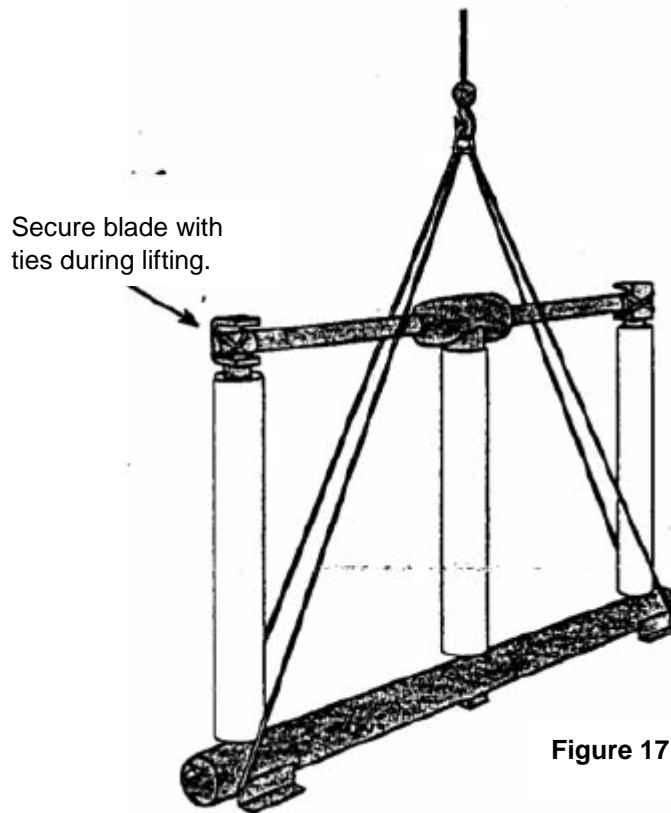


Figure 16: Adjust jaw up or down so that leading edge of blade tip touches the contact fingers first.

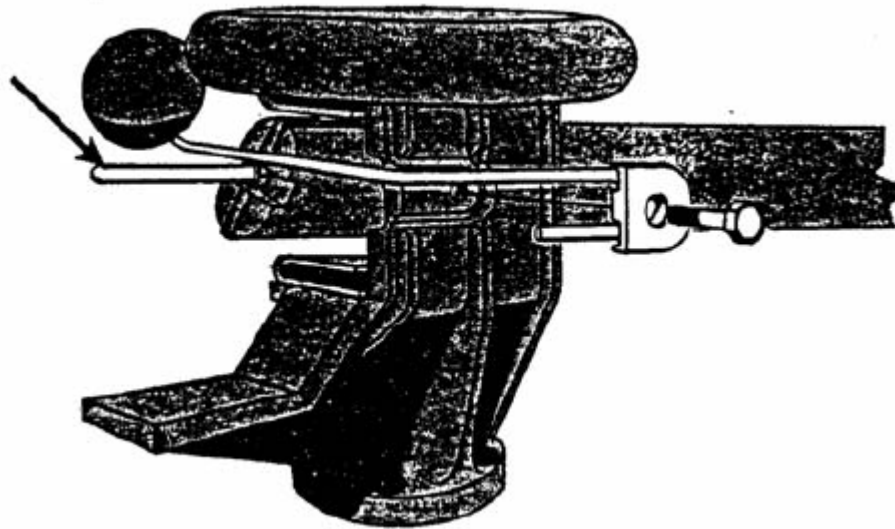
## Mounting and Final Adjustment

1. If the switch has been assembled on the ground, at this time mount it on the structure.  
LIFT BY THE SWITCH BASE ONLY.



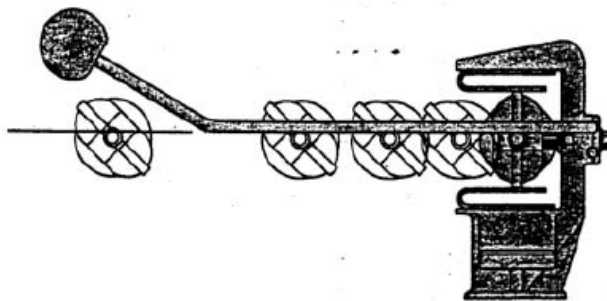
**Figure 17: Sling attachment**

2. If the adjustments described in the steps above were made while the switch was on the ground, carefully check contact engagement after the switch is bolted to the structure and the conductors are attached.  
**NOTE:** Final adjustment usually cannot be made on these switches until the conductors are attached, because conductor loads often pull tail insulator stacks several inches out of plumb. Therefore, if possible, install the conductors at this time to avoid the possibility of having to readjust the switch later.
3. Install the arcing horn and corona shield on each jaw as shown in Figure 18. The horns should touch *lightly* throughout their stroke. Arcing horns rubbing together with excessive pressure can cause the blade to rotate outside the contacts causing switch malfunction. Bend the stationary horn as required to achieve enough pressure for contact, but not so much as to cause binding.

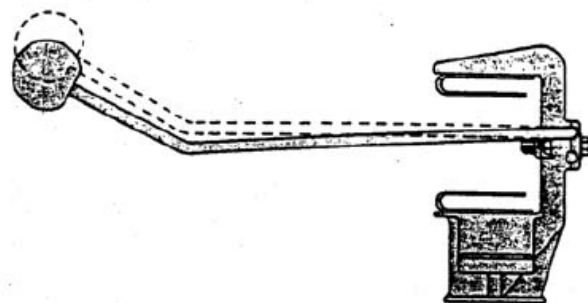


**Figure 18: Arcing horn attachment. Blade arcing horn (arrow) goes under jaw horn.**

**Arcing Horn Adjustment:**



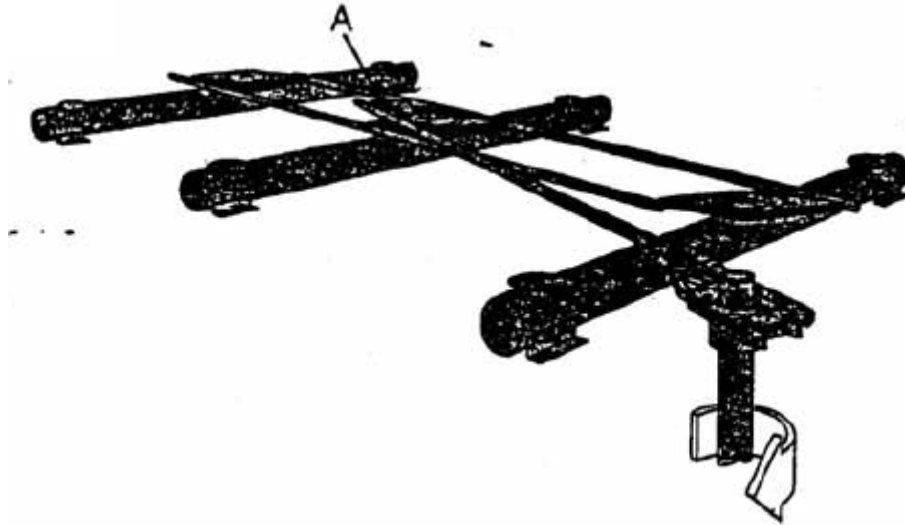
**Figure 19: Correct arcing horn adjustment has horn parallel to movement of the blade tip, allowing light contact through full length of engagement.**



**Figure 20: Improper adjustment allows arcing horn to droop into blade path. Could cause switch malfunction.**

4. When all adjustments are made, install the operating mechanism as directed on the following pages.

## Operating Mechanism



**Figure 21: Schematic drawing of a typical interphase pipe arrangement with the auxiliary switch arm at "A".**

1. Included with every switch is an Operating Mechanism Drawing (Op. Mech. Drawing). Study this drawing carefully, and with all switch poles closed, install mounting brackets, bushings, manual operation devices (if used), vertical pipe, adjustable crank arm, reach rod, and interphase pipe. *Be sure that pipe collar above the vertical bearing supports the full weight of the vertical pipe.*

**IMPORTANT:** On some installations you will find self-piercing set screws in the pipe clevises. These screws should be tightened to only grip the pipe during initial adjustments. **DO NOT** pierce the pipe until directed to do so.

**NOTE:** When a switch pole is equipped with an auxiliary arm, the best method for operating mechanism attachment is to wait until after this pole is completely adjusted before installing the interphase pipes. This will eliminate trying to coordinate and adjust all three poles at once.

2. After mounting all operating mechanism components, use any convenient means to match mark all clevis connections, adjustable arm, and manual operator attachments to check for slippage during trial operations.
3. If a motor operator is to be used, at the point refer to the motor operator installation instructions for mounting and trial operations.
4. Place all switch poles in the fully closed position.

Installation & Adjustment Procedures

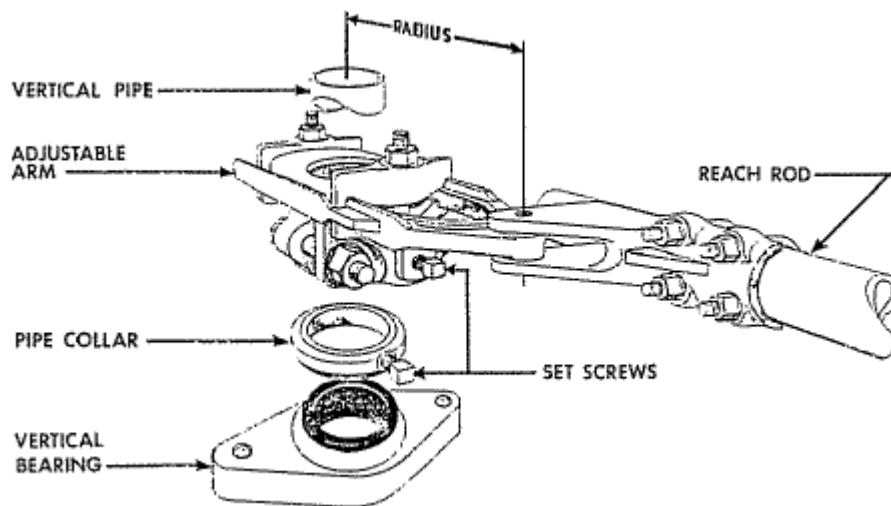


Figure 22: Adjustable arm assembly

**⚠ CAUTION** Pipe collar must support full weight of pipe.

5. ADJUSTMENT: If a motor operator is used, DO NOT use electrical operations until all adjustments are made. All grounding switch poles should be closed, all line switch poles open.
  - The adjustable arm should travel 180° from toggle closed to toggle open. Manually test operate.
  - If the switch does not fully open, the radius of the arm is too short. To correct:
    - a. Check first to see that nothing has slipped.
    - b. Return the switch to the closed position.
    - c. Loosen the adjustable arm and clevis bolts as shown below.
    - d. Lengthen the radius of the adjustable arm about ¼ inch and allow the clevis to reposition itself the same distance (shortening the pipe).
    - e. Test operate again and adjust as necessary.

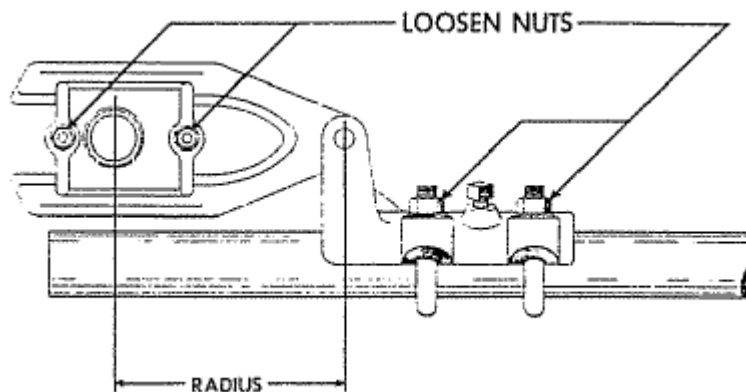


Figure 23: Adjustable arm

---

## Installation & Adjustment Procedures

- If the switch does not fully open, the radius of the arm is too short. To correct:
  - a. Check first to see that nothing has slipped.
  - b. Return the switch to the closed position.
  - c. Loosen the adjustable arm and clevis bolts as shown in Figure 20.
  - d. Shorten the radius of the adjustable arm about  $\frac{1}{4}$ " and allow the clevis to reposition itself the same distance (lengthening the pipe).
  - e. Test operate again and adjust as necessary.
- When the switch is completely adjusted, securely tighten all bolts and tighten all set screws until the pipe walls are pierced. For heavy wall pipe, drill the set screw holes, using the threaded drill guides supplied and a  $\frac{1}{4}$ " drill.

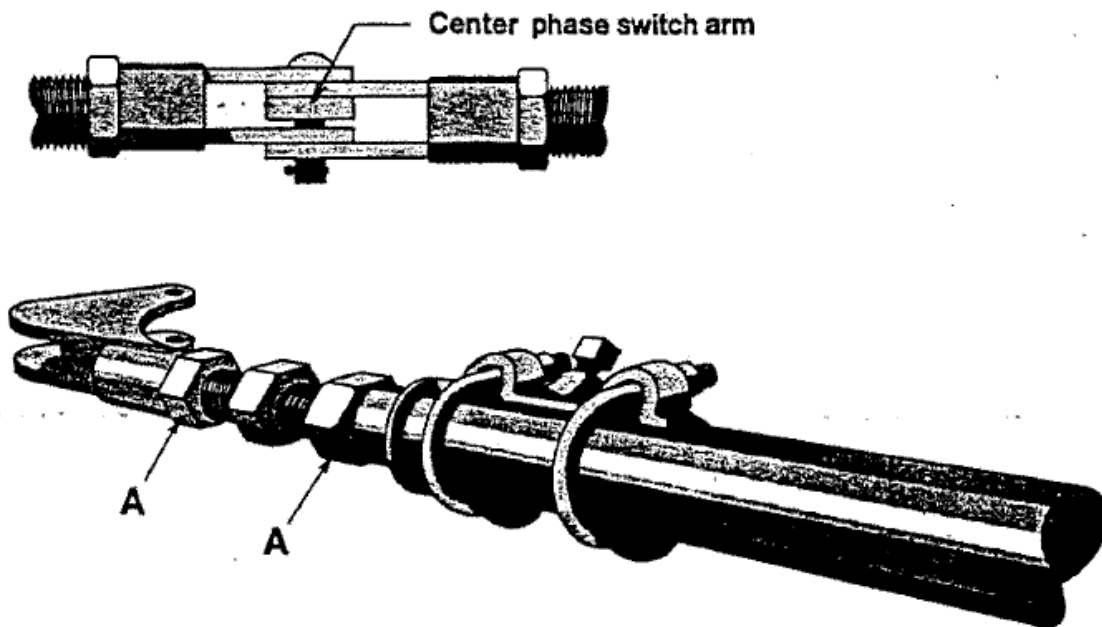
## Recommended Inspection Maintenance

---

It is recommended that maintenance on these switches be performed in accordance with ANSI STANDARDS C37.35-1976.

## General Instructions for Threaded Clevises

When threaded clevises are specified, one is generally attached to the adjustable arm, and two more to the center phase switch arm (refer to the plan view of the operating mechanism drawing and the illustration below).



Operating mechanism adjustments consist mainly of incremental lengthenings and/or shortenings of the pipe that connect the switch arms together. To make these adjustments, simply loosen both jam nuts "A" and screw the stud in or out as required. Be sure to retighten both jam nuts securely.

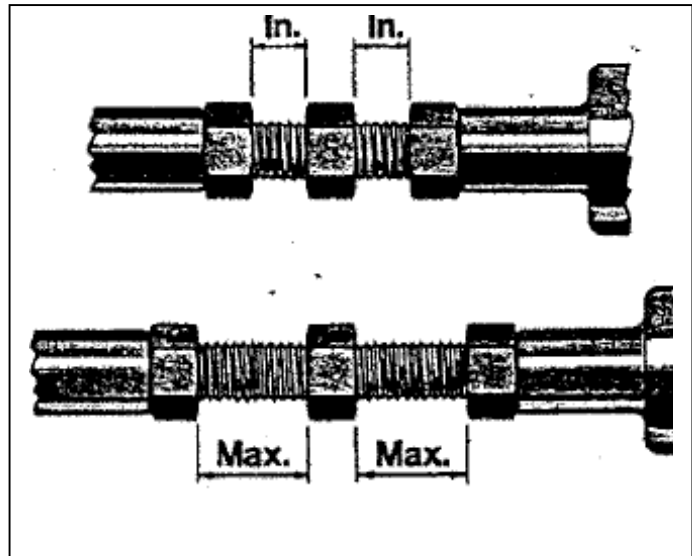
**▲ CAUTION ▲ DANGER** Do not screw the stud out of the clevises. This could cause the pipe to fall, resulting in serious injury to personnel below.

General Instructions for Threaded Clevises

Be sure the initial setting is correct, and do not adjust beyond the maximum allowable dimension. If adjustment beyond the maximum allowable dimension is needed loosen the U-bolts on the outboard phase clevis and reposition the pipe toward the center phase.

Initial dimension for  $\frac{3}{4}$ " stud is  $\frac{11}{16}$ "; 1" stud is  $\frac{1}{2}$ ".

Maximum allowable for  $\frac{3}{4}$ " stud is  $1\text{-}\frac{3}{16}$ ".  
Maximum allowable for 1" stud is 1".







# Southern States

**The Quality Name in High Voltage Switching**

30 Georgia Avenue  
Hampton, Georgia 30228  
Phone: 770-946-4562  
Fax: 770-946-8106  
E-mail: [support@southernstatesllc.com](mailto:support@southernstatesllc.com)  
<http://www.southernstatesllc.com>

©2015 Southern States, LLC  
IB-111-RDA.RDA-1 R2 345 03082016 Printed U.S.A.