

Southern States, Inc.

The Quality Name in High Voltage Products

Type RDA 500kV
Torsional Gear Arm Drive
Three Phase Operation

30 Georgia Ave,
Hampton, GA 30228
770-946-4562 Telephone
770-946-8106 Fax

Safety Information

DANGER

IMPROPER HANDLING, INSTALLATION, OPERATION OR MAINTENANCE OF THIS EQUIPMENT MAY CAUSE IMMEDIATE HAZARDS WHICH WILL LIKELY RESULT IN SERIOUS PERSONNEL INJURY OR DEATH.

WARNING

The equipment covered by this publication must be handled, installed, operated and maintained by qualified persons who have direct knowledge and experience dealing with the hazards involved and are thoroughly trained in the handling, installation, operation and maintenance of high voltage transmission and distribution equipment. These instructions are meant for only such **Qualified Persons**. They are not intended to be a substitute for adequate training and experience in safety procedures for this type of equipment.

A **Qualified Person** is one who is trained in and has skills necessary:

- to read and comprehend this instruction book – understanding that these instructions are general in nature
- to accept personal responsibility to prepare and maintain an intrinsically safe work environment and maintain control of the work site to safeguard all persons present
- to develop and implement a proper rigging, lifting, and installation plan along with all safety precautions required to insure safe and proper lifting and installation of the equipment.
- to distinguish between energized and non energized parts
- to determine proper approach distances to energized parts
- to properly work with and around energized or de-energized equipment that may be pressurized with gas
- for proper use of personal protective equipment, insulating and shielding materials, insulated tools for working near energized and /or pressurized electrical equipment
- to recognize and take necessary precautions for the unique and dynamic conditions of site and specialized equipment to maintain a safe work environment during handling, installation, operation, and maintenance of high voltage switching equipment

The instructions in this manual are general guidelines for this type of equipment and not specific to the equipment supplied. Portions of it may not be applicable or may not have complete instructions for your specific equipment.

If you do not understand any part of these instructions or need assistance, contact Southern States Service Division at 770-946-4562 during normal business hours (EST) or 770-946-4565 after normal business hours.



LIMITED WARRANTY

Southern States, LLC (“SLLC”) warrants only to the Warranty Holder (hereinafter defined as the “End User” or the “Immediate Purchaser”, as applicable, pursuant to the terms and conditions of this Limited Warranty as set forth below), that the Product identified below will, upon shipment, be free of defects in workmanship and material for the applicable Warranty Period. The “Warranty Period” is that period of time during which this Limited Warranty is effective, and such period begins on the invoice date issued by SLLC for the Product, and continues until the earlier to occur of (1) the expiration of the Warranty Duration period, or (2) the Number of Operations, both as specified in the table below. If the Product is both purchased and installed within the United States or Canada, this Limited Warranty is granted to each end user of the Product who acquired the Product for its own use during the Warranty Period (“End User”). In all other situations, this Limited Warranty is granted only to the first purchaser of the Product (“Immediate Purchaser”) from SLLC. No primary or remote purchaser or owner of the Product who is not a Warranty Holder may claim any benefit under this Limited Warranty, or any remedial promise included in this Limited Warranty. SLLC shall, upon prompt written notice from the Warranty Holder, correct a nonconforming Product by repair or replacement at the sole discretion of SLLC of the nonconforming Product or any part or component of a nonconforming Product necessary in SLLC’s discretion to make such Product conforming. Any transportation charges, labor for removing, reinstalling the Product or part, and/or costs related to providing access to the Product shall be the responsibility of the Warranty Holder. Correction in this manner will constitute the Warranty Holder’s exclusive remedy and fulfillment of all SLLC’s liabilities and responsibilities hereunder. SLLC’s duty to perform under this limited warranty may be delayed, at SLLC’s sole option, until SLLC has been paid in full for all products purchased by the Warranty Holder. No such delay will extend the Warranty Period. If SLLC does not make such repair or replacement, SLLC’s liability for damages on account of any claimed nonconformity will in no event exceed the purchase price of the Product in question. This Limited Warranty does not apply to any Product that has been disassembled, repaired, or altered by anyone other than SLLC. This Limited Warranty will not apply to any Product that has been subjected to improper or abnormal use of the Product. SLLC has no responsibility to repair or replace any Product or component thereof manufactured by another party, but SLLC will assign, to the extent assignable, to the Warranty Holder any manufacturers’ warranty that applies to products and components not manufactured by SLLC.

THIS LIMITED WARRANTY IS EXCLUSIVE AND IN LIEU OF ALL OTHER WARRANTIES. THERE ARE NO OTHER EXPRESS, IMPLIED, OR STATUTORY WARRANTIES. ALL IMPLIED WARRANTIES WHICH MAY ARISE BY IMPLICATION OF LAW, OR APPLICATION OF COURSE OF DEALING OR USAGE OF TRADE, INCLUDING, BUT NOT LIMITED TO, IMPLIED WARRANTIES OF MERCHANTABILITY OR FITNESS FOR A PARTICULAR PURPOSE, NONINFRINGEMENT OR OTHERWISE ARE EXPRESSLY EXCLUDED. SLLC SHALL NOT BE LIABLE OR RESPONSIBLE FOR ANY CONSEQUENTIAL, INCIDENTAL, INDIRECT, EXEMPLARY, SPECIAL, OR PUNITIVE DAMAGES, EVEN IF SLLC HAS BEEN ADVISED OF THE POSSIBILITY OF SAME. THE WARRANTY HOLDER IS SOLELY RESPONSIBLE FOR THE SUITABILITY OF THE PRODUCT FOR ANY PARTICULAR APPLICATION.

Product Purchased Region	Product Installed Region	Warranty Holder	Warranty Duration
U.S and Canada	U.S and Canada	End User	Five (5) Years
All Other Conditions		Immediate Purchaser	Earlier of 1 year from installation or 18 months from shipment

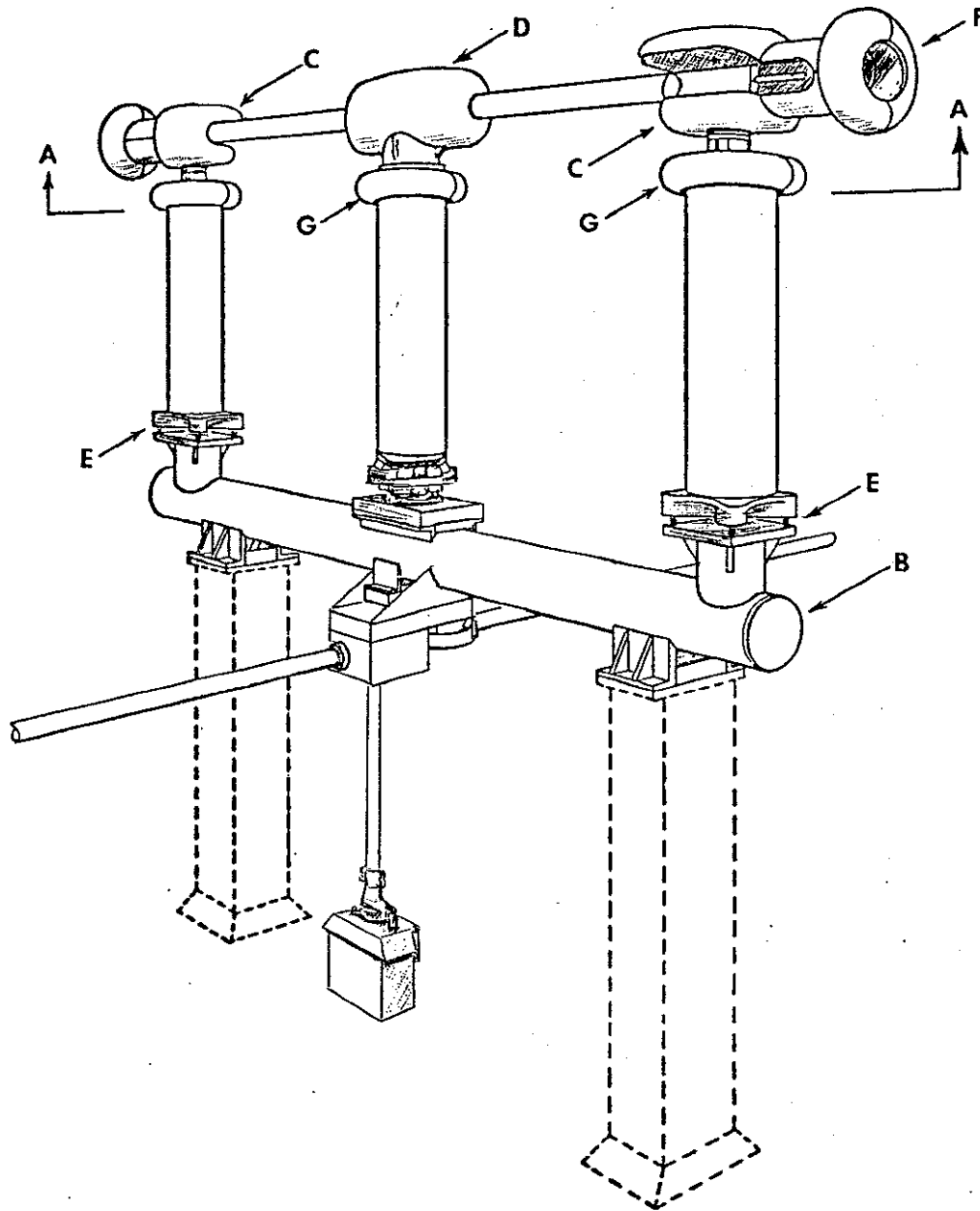

Figure 1 — This illustration shows an RDA with motor operation. The purpose of this drawing is to show relationships of the parts, and not specific components. For mounting dimensions, refer to the Operating Mechanism drawing that comes with each switch.

- | | |
|-----------------------------------|--------------------|
| A — Live parts | E — Jack screws |
| B — Base | F — Corona shields |
| C — Jaws | G — Corona rings |
| D — Live part operating mechanism | |

These instructions give the general procedure for adjusting RDA 500 kV switches. It may be necessary to make adjustments not described in this manual. If any questions should arise concerning the installation or adjustment of this equipment, please call your local Southern States representative, or the factory.

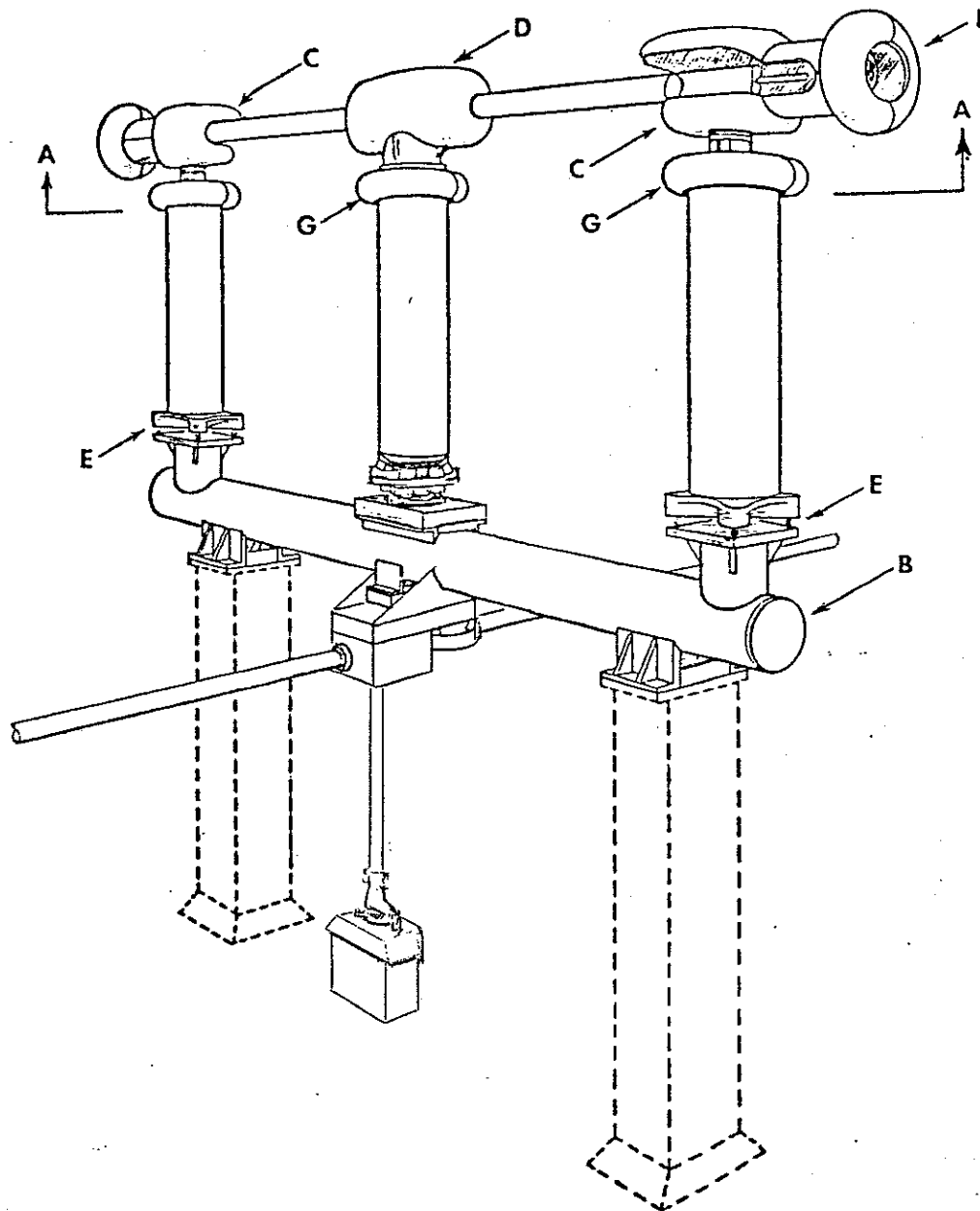

Figure 1 — This illustration shows an RDA with motor operation. The purpose of this drawing is to show relationships of the parts, and not specific components. For mounting dimensions, refer to the Operating Mechanism drawing that comes with each switch.

- | | |
|-----------------------------------|--------------------|
| A — Live parts | E — Jack screws |
| B — Base | F — Corona shields |
| C — Jaws | G — Corona rings |
| D — Live part operating mechanism | |

These instructions give the general procedure for adjusting RDA 500 kV switches. It may be necessary to make adjustments not described in this manual. If any questions should arise concerning the installation or adjustment of this equipment, please call your local Southern States representative, or the factory.

These instructions describe the steps to install this switch on the structure — that is, first bolting the base to the station columns, then the insulators to the base, and so on. Another procedure that is often used is assembling the entire switch on the ground, then hoisting it to the structure. This can save many operations from a bucket truck, but since each switch weighs approximately 7000 pounds, heavier equipment may be needed. To use this alternate method:

1. Bolt the base to a firm mounting surface that is level and stable. Metal sawhorses, or their equivalent, may have to be constructed.
2. Follow the steps in paragraphs I, II, III, V, and VI.
3. At the completion of paragraph VI lift the assembled switch pole to the mounting structure and bolt it into place. When doing this, be sure to refer to the Operating Mechanism drawing, because there are differences in each switch pole, and they must be positioned properly.
4. Proceed with the adjustment described in paragraph VII.

NOTE: All drawings in this manual are for illustration only. Actual switch components may differ slightly in appearance.

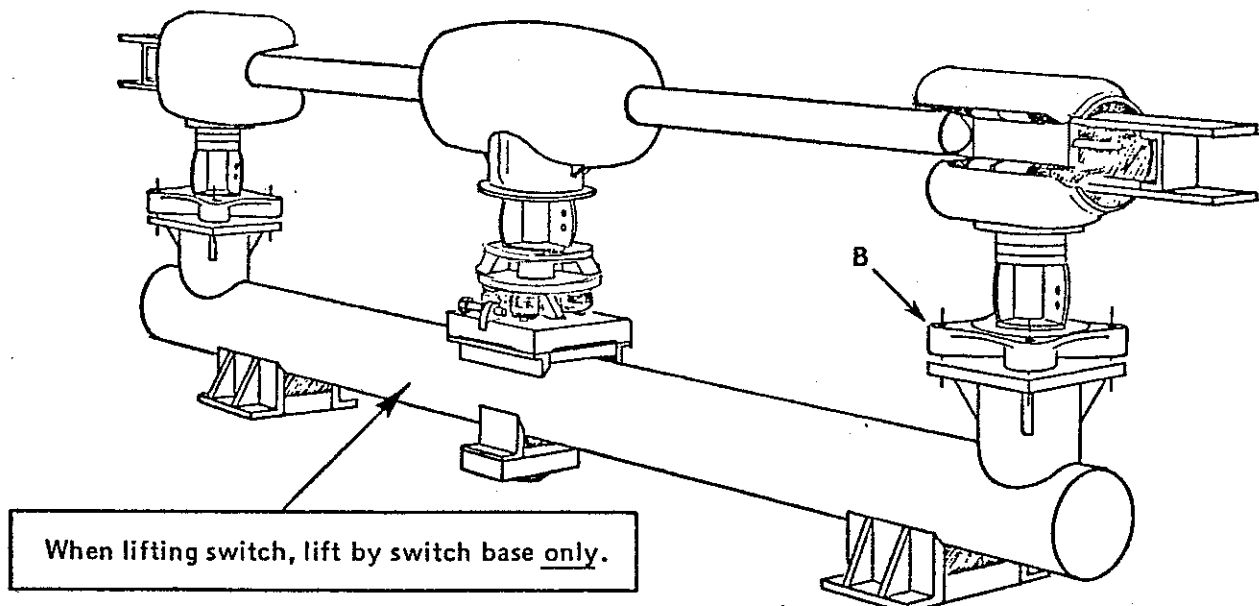

Figure 2 - The switch as shipped. Depending upon shipping constraints, the torsional drive gearboxes and grounding switch hinge assemblies (if applicable) may be shipped attached to the switch base. Other components such as corona shields, operating mechanism components, brackets, nuts, bolts, etc., are boxed separately. The insulator mounting adaptor (B) may be either the casting shown, or a 1/2" steel plate.

I. UNPACKING AND INSPECTION

1. Remove all shipping ties and check for damage in shipment. Unpack and lay out all boxed components, bolts, operating pipes, etc., and check against the bill of material on the Operating Mechanism drawing.
2. Do not attempt to make any adjustment or install any component until directed to do so in this manual.
3. Read this instruction manual before beginning any work.

II. INSTALLATION

Installation consists of partial disassembly (removal of the live parts from the base on which they are shipped), mounting the base on the structure, mounting the insulators to the base, and mounting the live parts atop the insulators. Certain adjustments are also necessary, since insulator and structure irregularities prevent fine adjustment at the factory.

III. REMOVAL OF THE LIVE PARTS

OPEN SWITCH BEFORE UNBOLTING LIVE PARTS

1. Make reference marks as shown in figure 3 to ensure correct reassembly.
2. Open the switch by rotating the coupling on the gearbox.
3. Remove the bolts that mount the jaws to the base adaptor. See Figure 4. There will be two 1/2 inch spacers that fit under each jaw. Retain these spacers with the jaw for later use.

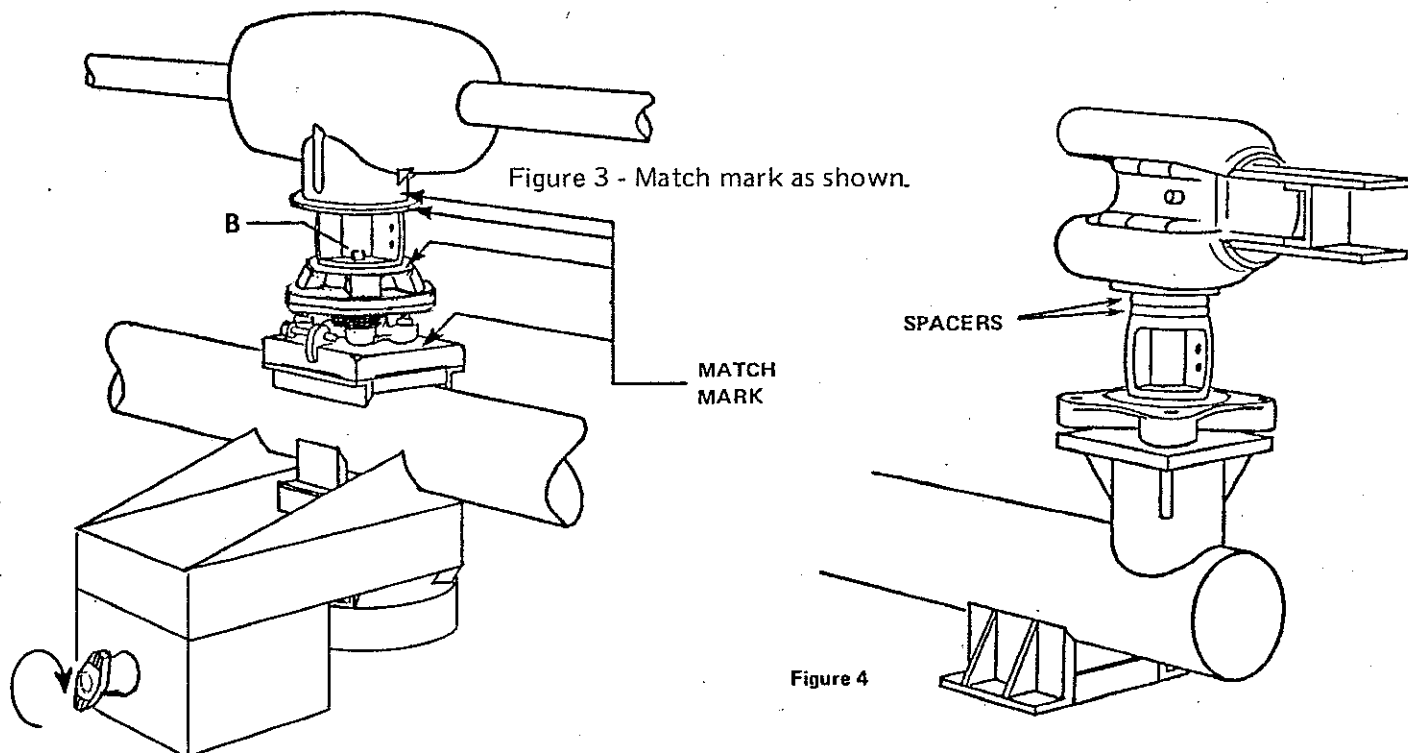

4. After matchmarking the components shown in Figure 3, remove the blade and "Watermelon," housing as a unit by removing the shipping bolts "B".

IV. MOUNTING THE BASE

Check the Op. Mech. drawing for the proper position of each switch pole, and verify that the mounting surfaces have the correct spacing and elevation. Bolt the switch base to its mounting position, using the bolts specified on the Op. Mech. drawing.

The mounting surfaces must be level. If they are not, use shims between the switch base mounting feet and the structure to level the switch base.

V. MOUNTING THE INSULATORS

1. If possible, assemble all insulator stacks on the ground, and hoist each stack as a completed unit. In mounting the insulator stacks, the best method is to unscrew the top nuts from the jack screws and remove the mounting adaptor from the switch base; the adaptor then can be more easily bolted to the bottom of the insulator stack, due to better access with a socket wrench. Refer to the Field Assembly Bolt List (SF drawing) for the proper bolts.

NOTE: All insulator to adaptor bolts and nuts are high strength A-325. Hoist the stack and adaptor to the base and bolt down securely with the top jack screw nuts.

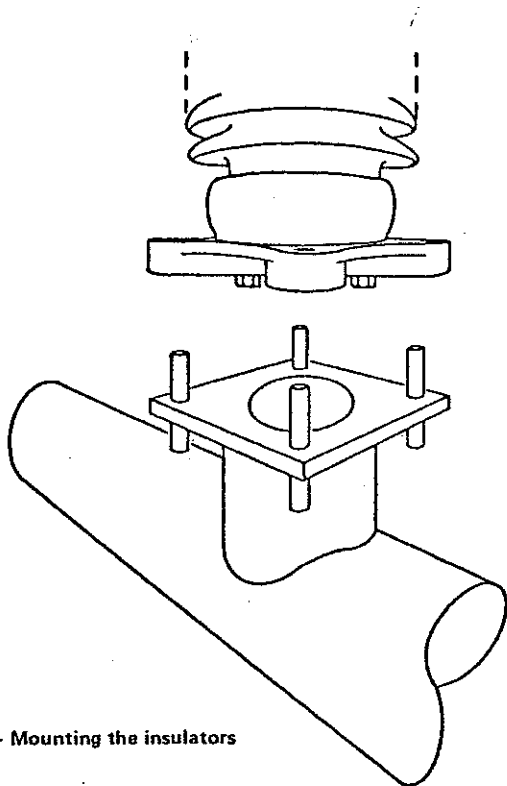

Figure 5 – Mounting the insulators

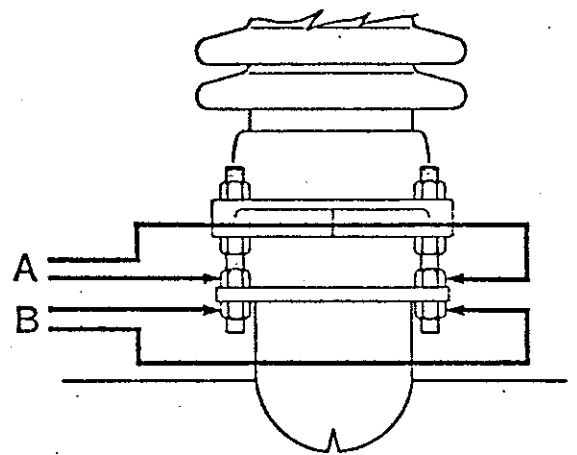

Figure 6 – To adjust the insulator stack, loosen four nuts (B). Tilt insulator to required position by screwing up or down on nuts (A). Retighten nuts (B).

2. Use a plumb bob or level and true up the end insulators. It is important that they be perpendicular to the base in both planes. Use the jack screws to level these stacks. (Due to the overhang of the insulator skirts, it will be necessary to use a piece of scrap metal or wood to extend the plumb bob string beyond the skirts.)
3. The rotating insulator requires special attention to ensure good switch operation. It is necessary that this stack rotate about its axis uniformly; that is, it must not “wobble” as it rotates. However, due to irregularities in the mounting faces of individual insulator units, it is not unusual for an insulator stack to be out of alignment six inches or more. And while this switch is designed to tolerate a certain amount of misalignment, the rotating insulator should be adjusted so that evident “wobble” is 1/2 inch or less. The best procedure to achieve this is described on the following page.

Figure 7 — Adjusting the rotating insulator for concentric rotation.

PREPARATION

Make a marker of any convenient material such as metal angle or lumber. Make a sharp pointer and attach it to the center of the marker. Place the marker over the center of the rotating insulator in such a manner that it can be used as a reference point but does not drag on the insulator top during rotation. Blocks of wood, etc. can be used on the ends to compensate for sag. The marker should be free to be repositioned, as described below.

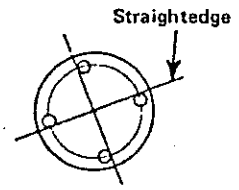
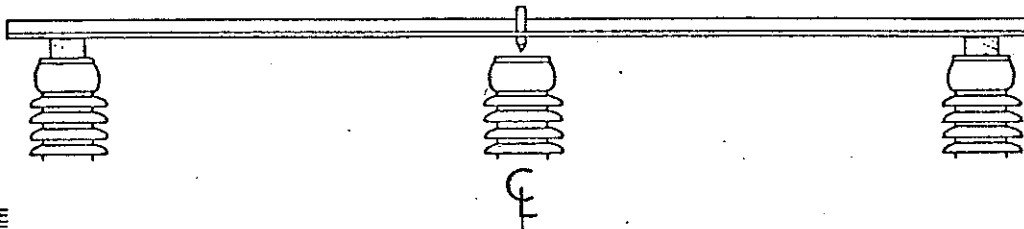

STEP ONE

Rotate the insulator up against a bearing stop, and position the reference point over the center of the insulator top.

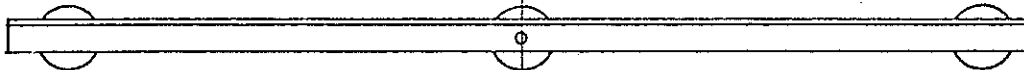

Method for finding insulator center

STEP TWO

Rotate the insulator to the opposite bearing stop. Observe for eccentric rotation ("wobble").

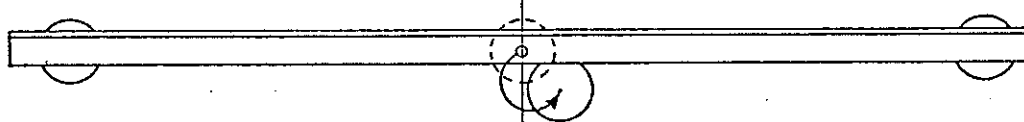

STEP THREE

If during rotation the insulator has wobbled, leave it against the bearing stop in step two. Use the jack screws that mount the rotating insulator to the bearing to tilt it back one-half the distance to the reference point on the marker.

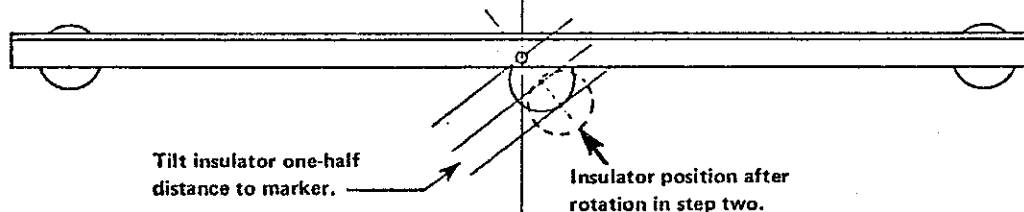

STEP FOUR

Rotate the insulator back to the beginning position (step one). Reposition the reference point over the center of the insulator. Repeat the last three steps until the insulator rotates true.

This method works whether the rotating insulator is out of adjustment axially, laterally, or any combination in between.

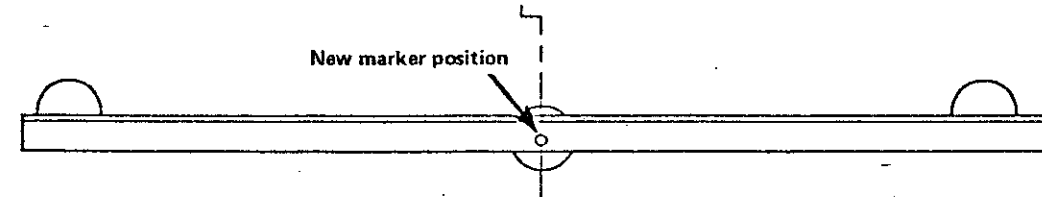

NOTE: IMPORTANT: — Once the insulator is adjusted to rotate true, DO NOT READJUST or otherwise change its jack screw settings.

VI. MOUNTING THE LIVE PARTS

1. Mount the "Watermelon" housing and blade assembly to the center insulator, making sure the match marks are aligned.

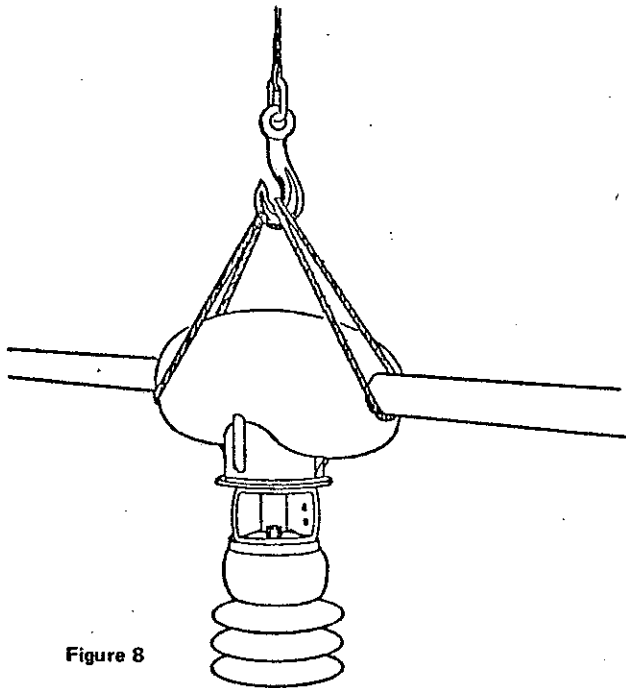

Figure 8

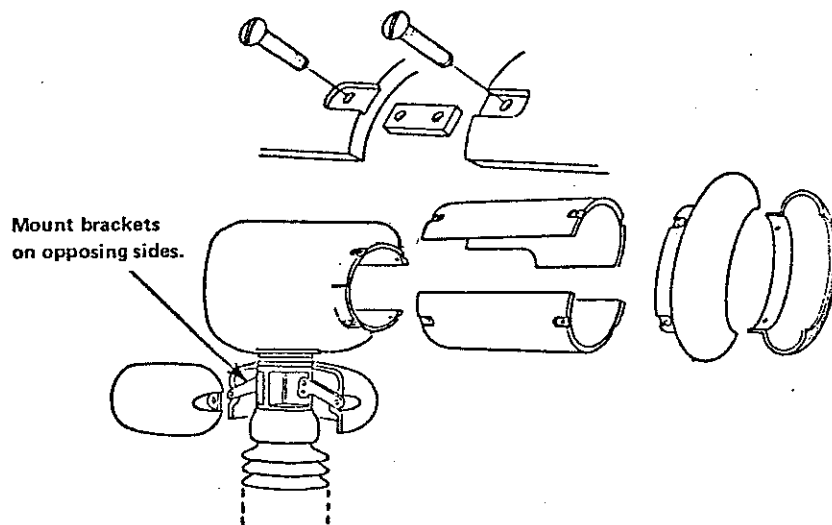
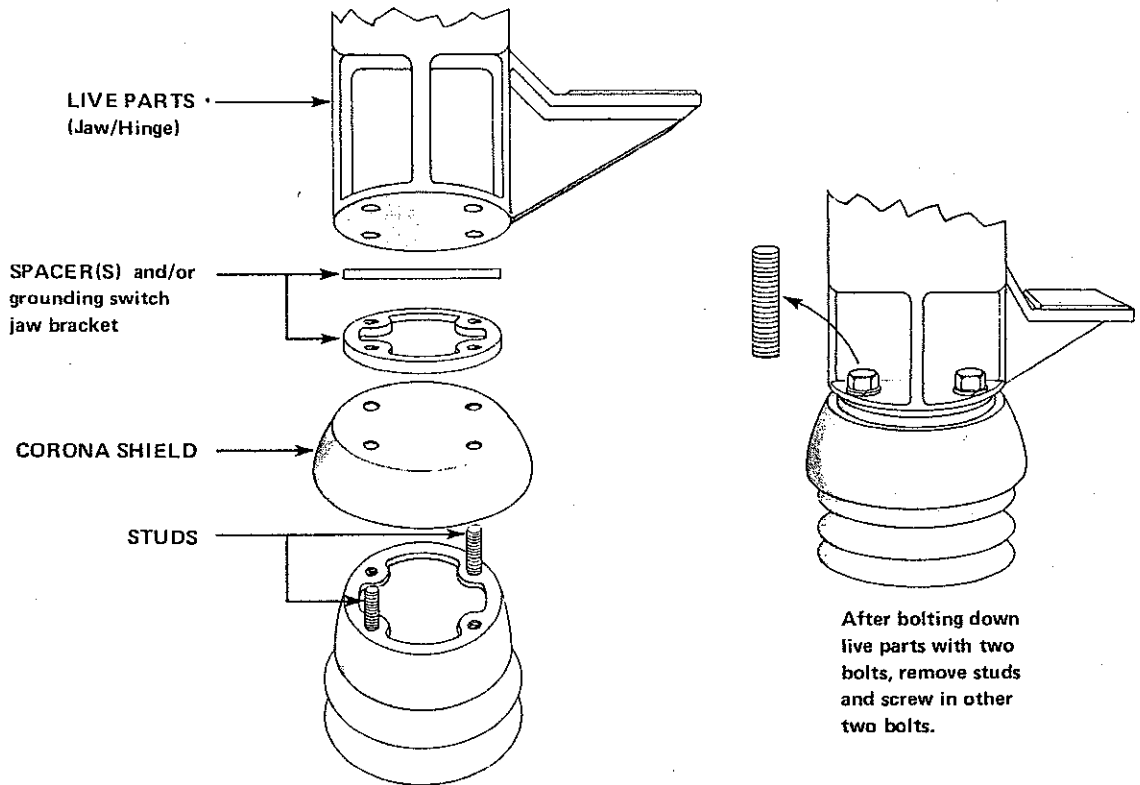

Figure 9

2. Mount the two jaws on their respective stacks. It will be necessary to open the switch slightly to do this.
If a grounding switch is used, the grounding switch jaw should be mounted at this time. Refer to the Op. Mech. Drawing and mount the grounding switch jaw bracket, and only one spacer. The spacer is mounted above the grounding switch jaw bracket.
3. The corona rings may be attached whenever convenient. However, the shields that cover the terminals cannot be mounted until after the conductors are attached.
Note: The brackets to which the jaw rings are mounted are attached on opposing sides of the jaw mounting surfaces. See figure 9.

TIMESAVING TIP for mounting live parts when hardware must be placed between the insulator and the live parts: Use two studs of sufficient length to allow later removal (easily made by cutting the heads off two bolts) to align the parts. Bolt the live parts down with mounting bolts, using the two free holes; then remove the studs and screw in the other two bolts.



This procedure can cut a significant amount of time from installation, and will work in all cases except on the center insulator of the double-side-break RDA, RDA-1, and RDC switches.

Where alignment difficulties are encountered with the center stack on double side break switches, matchmark and remove the top insulator unit (after adjustment for concentric rotation) and bolt the parts together on the ground, where alignment will be easier. Then hoist the blade mechanism assembly and top insulator section into position as an assembled unit and reattach the insulator sections. This will eliminate having to align three non-captive parts in the air. However, if this procedure is used, be sure to matchmark the top insulator unit with the next lower unit before removal in order to preserve the concentric rotation adjustments previously made and properly orient the live parts.

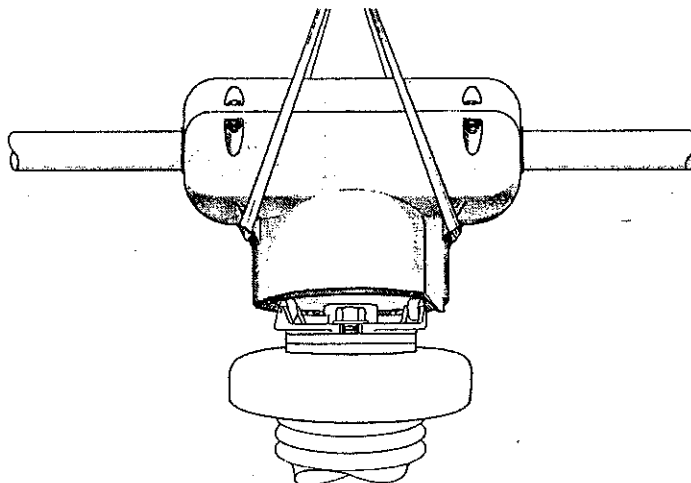

4. Final adjustment usually cannot be accomplished until the conductors are installed. This is because it is not unusual for the weight of long conductors to pull tall insulator stacks several inches out of plumb. For this reason, the conductors should be installed at this time to avoid later readjustments of the switch.
5. The arcing horns should be attached at this time. (Figure 10) The arcing horns should rub together with sufficient pressure to maintain contact throughout their stroke; however, they should not bind or force the blade out of alignment. The jaw horn can be bent as required to achieve proper contact.

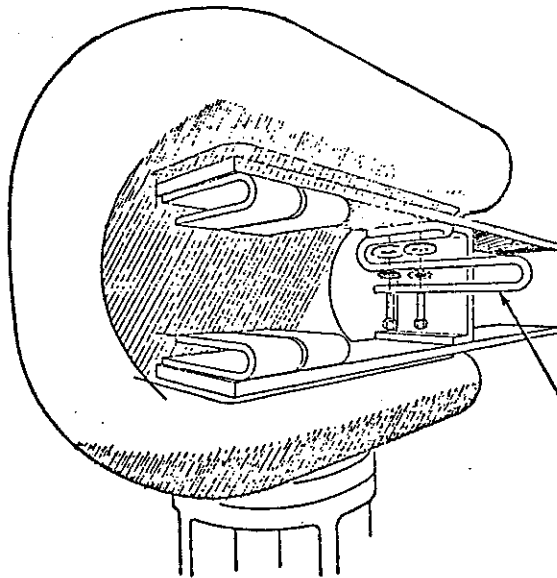

Figure 10

Arcing horn is attached with two 1/2 x 1-1/4 stainless steel hex bolts, plus E.S.P.W. and plainwasher.

6. Refer to the grounding switch installation booklet. Although the grounding switch(es) should not be adjusted until after the line switch is completely adjusted, bearing supports and certain operating pipes can be installed prior to lifting the assembled switch to the structure, which will save time and bucket lift operations.

VI. ADJUSTMENT

Although adjusted at the factory before shipment, any of several factors can cause minor adjustments to become necessary in the field. Final adjustments usually cannot be made until the conductors are attached to the switch terminals.

Requirements of proper adjustment (prior to installing the operating mechanism):

1. The blade must enter each jaw on a horizontal plane. It also must enter each jaw centrally, without dragging on either the upper or lower jaw contact surface. (Figure 11) Misalignments can be corrected by using the jack screws on the insulator that supports the jaw to raise or lower the jaw as necessary to permit central entry of the blade.
2. Each blade tip must strike the bumper in each jaw simultaneously when closing. (Figure 12)
 - If a jaw appears to receive the blade tip early or late, use the jack screws to tilt the jaw insulator toward or away from the blade tip as required.

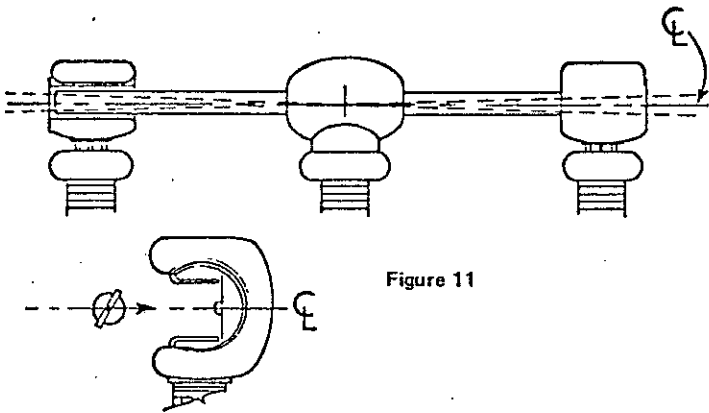

Figure 11

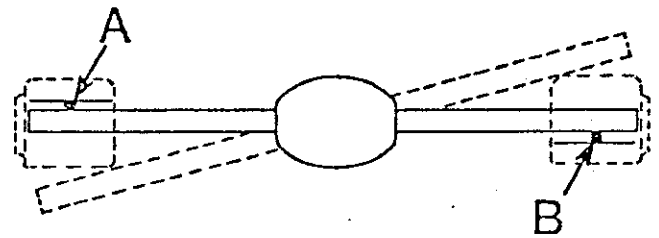

Figure 12

The switch blade should hit both stops "A" and "B" simultaneously.

3. The silver on the jaw contact leaves must be centered on the silver strips of the blade tip. (Figure 13)
 - If proper contact centering is not observed, adjust the jack screws of the jaw insulator to tilt the jaw fore or aft (on the base centerline) to center the contact surfaces.
4. When the operating arm at the base of the rotating insulator is against the closed position stop, the blade tip should be vertical in the jaw contacts. (Figure 14)
 - If necessary, run the closed position stop in or out to achieve proper contact. These switches will have adequate contact pressure if the blade tip is as much as five degrees off vertical; however, every attempt should be made to get the tip as nearly perpendicular in the contacts as possible.

Only after these four requirements are satisfied should the operating mechanism be installed.

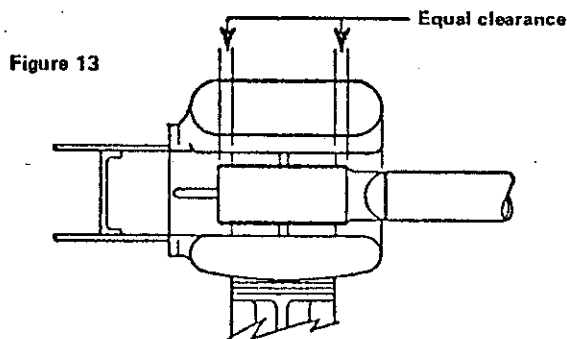

Figure 13

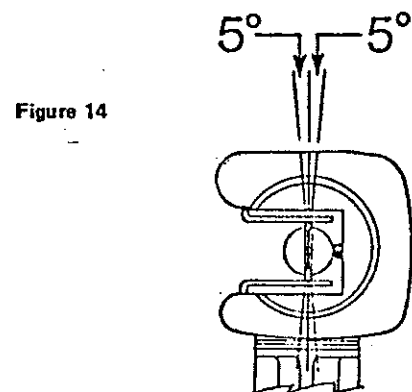

Figure 14

VII. MAINTENANCE

It is suggested that maintenance on these switches be performed in accordance with ANSI STANDARDS C37.35-1976.



Installation Instructions Supplement

After all contact adjustments are made and the switch is operating satisfactorily - but before installing the operating mechanism pipes - check each switch pole for proper metal-to-metal open gaps. This is done in the following manner:

- Refer to the unit assembly drawing for the open gap dimension.
- Open the switch completely and measure the open gap. The easiest way to do this is to cut a board to the proper length and, placing it against the jaw as shown below, move it in an arc toward the blade and hinge parts. Check both ends of each switch pole.
- If the switch blade is within the arc of the board, back off the open position stop on the insulator bearing on the base until the correct gap is obtained. Make sure the tang on the switch arm touches the stop bolt head, because this is the open position reference point when installing the operating pipes.
- Make sure that all three poles have the same open gap.

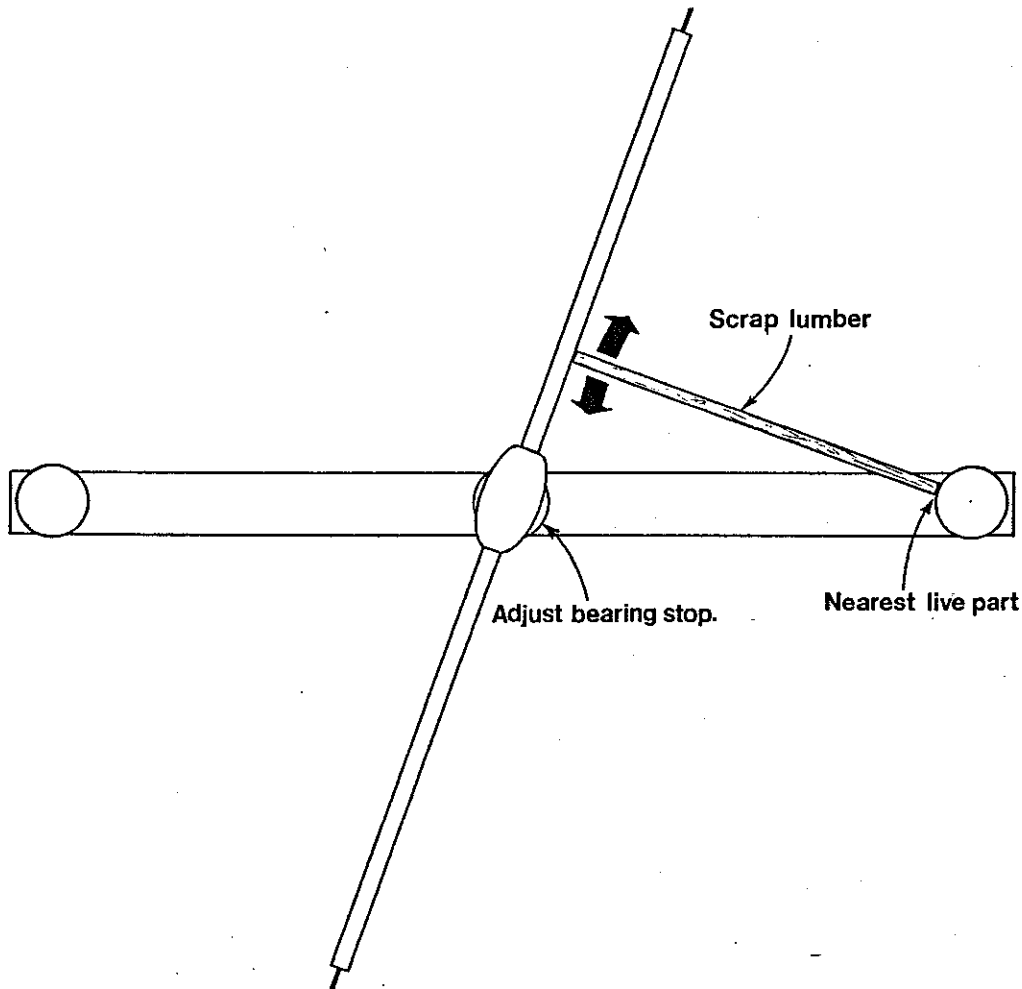

This switch uses a torsional type of operating mechanism with a multiple-revolution motor operator transmitting torque through factory-installed gearboxes to open and close each three phase switch.

Shown below is a schematic drawing of the operating mechanism. See the Op. Mech. Drawing for detailed mounting dimensions, and proper positioning of switch poles.

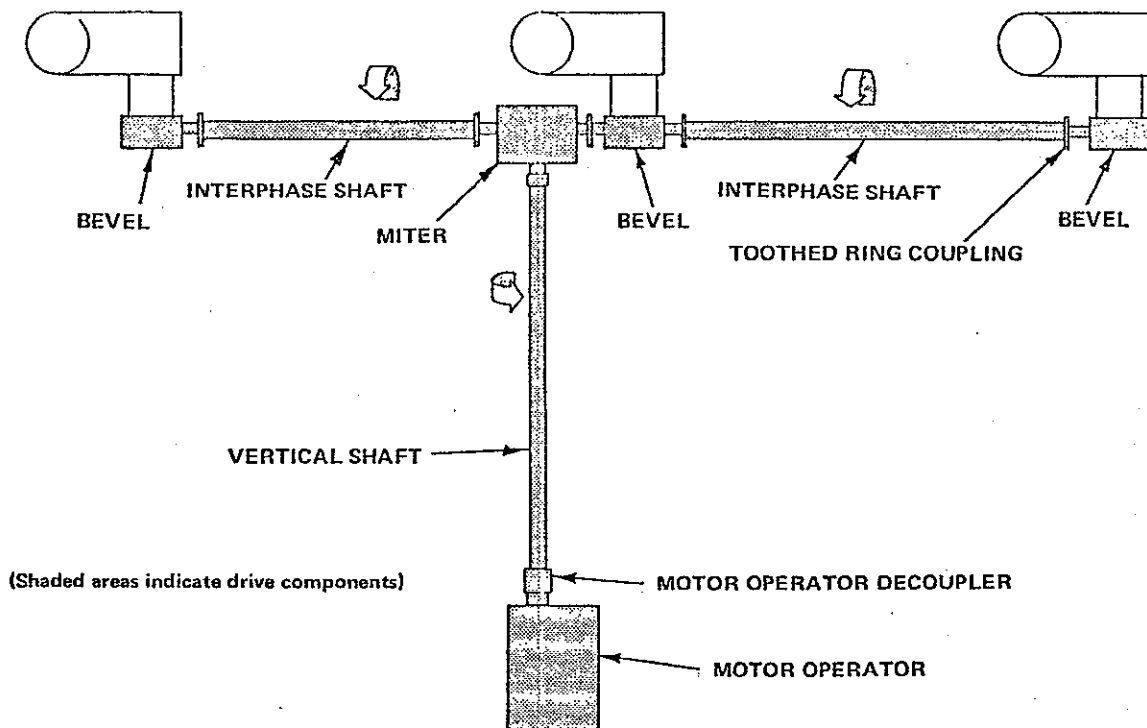

INSTALLATION:

CAUTION: DO NOT USE ELECTRICAL OPERATION UNTIL ALL OPERATING MECHANISM ADJUSTMENTS ARE COMPLETED.

After each pole has been mounted on the structure and checked out thoroughly for proper opening and closing, refer to the Op. Mech. Drawing and install the vertical operating shaft.

NOTE: Tighten set screws to grip pipe, but do not pierce pipe until directed to do so.

- II. Place all poles in the fully closed position and install the interphase shafts. The sketch below shows the method of attachment of these components. The toothed ring is to facilitate fine adjustment of each individual switch pole.

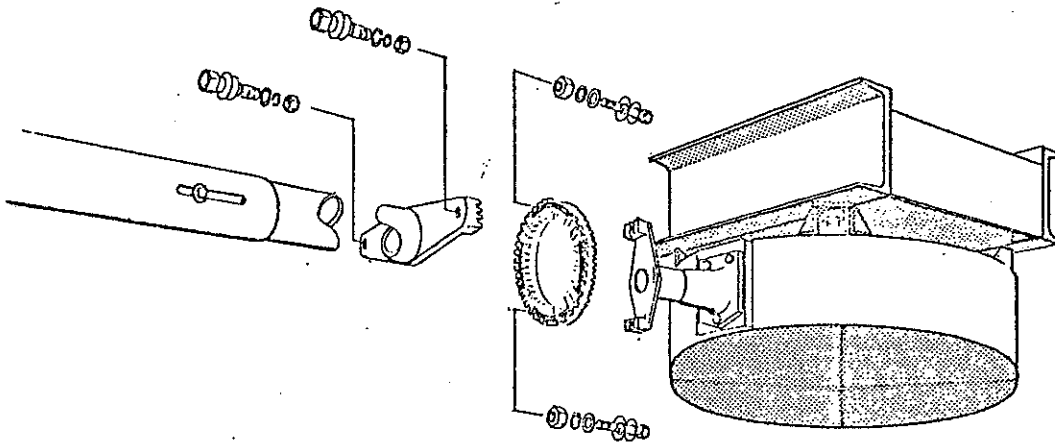

- III. Install the motor operator in the closed position as directed in the motor mechanism installation instructions. DO NOT allow the motor operator to support the weight of the vertical operating shaft.

ADJUSTMENT:

- IV. Match mark any pipe connection that might slip during trial operations.
- V. **HAND OPERATE ONLY**, using the manual crank on the motor operator. Using the stops on the switch poles for reference, perform several trial operations on the switch. All three poles should operate uniformly with both simultaneous openings and simultaneous closings being observed.

If non-uniform operation is noted, first check to see that nothing has slipped, then disconnect the toothed ring on the affected switch pole and either advance or retard the motion of the pole as necessary.

- VI. After the three phase switch operates manually in a satisfactory manner, coordinate the operation of the line switch with that of the motor mechanism. This is done as follows: Note the EXACT position that the lower decoupler member rests in when the line switch is both OPEN and CLOSED. This can be done best by match marking the decoupler with respect to the top of the motor operator housing.
- VII. Decouple the motor mechanism and operate it electrically, checking the position that the match marks rest in after both open and close *electrical* operations. If necessary, adjust the limit switches as directed on the motor mechanism installation instructions to match the rotation of the motor mechanism *exactly* to that of the switch. The closed position lock is adjustable to allow for rotational irregularities.
- VIII. When the adjustments in step VII are completed, couple the motor mechanism to the switch and test electrically.
- IX. When all the above adjustments are completed tighten all set screws until pipe walls are pierced,* and give all nuts, bolts, etc. a final check.

*It will be necessary to pre-drill all set screw holes to allow penetration of the heavy wall pipe.



Southern
States, Inc.



The Quality Name in High Voltage Switching

30 Georgia Avenue
Hampton, Georgia 30228
Phone: 770-946-4562
Fax: 770-946-8106
E-mail: support@southernstatesllc.com
<http://www.southernstatesllc.com>

©2015 Southern States, LLC
IB-111-RDA 500 3Phase Gear-Rev 1 100815 Printed U.S.A.