



The Quality Name in High Voltage Switching

TYPE EC-1V

Aluminum
Center Break Vee
Disconnect Switch

ALL Ratings

INSTALLATION &

INSTRUCTION

MANUAL

Safety Information

DANGER

IMPROPER HANDLING, INSTALLATION, OPERATION OR MAINTENANCE OF THIS EQUIPMENT MAY CAUSE IMMEDIATE HAZARDS WHICH WILL LIKELY RESULT IN SERIOUS PERSONNEL INJURY OR DEATH.

WARNING

The equipment covered by this publication must be handled, installed, operated and maintained by qualified persons who have direct knowledge and experience dealing with the hazards involved and are thoroughly trained in the handling, installation, operation and maintenance of high voltage transmission and distribution equipment. These instructions are meant for only such **Qualified Persons**. They are not intended to be a substitute for adequate training and experience in safety procedures for this type of equipment.

A **Qualified Person** is one who is trained in and has skills necessary:

- to read and comprehend this instruction book – understanding that these instructions are general in nature
- to accept personal responsibility to prepare and maintain an intrinsically safe work environment and maintain control of the work site to safeguard all persons present
- to develop and implement a proper rigging, lifting, and installation plan along with all safety precautions required to insure safe and proper lifting and installation of the equipment.
- to distinguish between energized and non energized parts
- to determine proper approach distances to energized parts
- to properly work with and around energized or de-energized equipment that may be pressurized with gas
- for proper use of personal protective equipment, insulating and shielding materials, insulated tools for working near energized and /or pressurized electrical equipment
- to recognize and take necessary precautions for the unique and dynamic conditions of site and specialized equipment to maintain a safe work environment during handling, installation, operation, and maintenance of high voltage switching equipment

The instructions in this manual are general guidelines for this type of equipment and not specific to the equipment supplied. Portions of it may not be applicable or may not have complete instructions for your specific equipment.

If you do not understand any part of these instructions or need assistance, contact Southern States Service Division at 770-946-4562 during normal business hours (EST) or 770-946-4565 after normal business hours.

LIMITED WARRANTY

Southern States, LLC (“SLLC”) warrants only to the Warranty Holder (hereinafter defined as the “End User” or the “Immediate Purchaser”, as applicable, pursuant to the terms and conditions of this Limited Warranty as set forth below), that the Product identified below will, upon shipment, be free of defects in workmanship and material for the applicable Warranty Period. The “Warranty Period” is that period of time during which this Limited Warranty is effective, and such period begins on the invoice date issued by SLLC for the Product, and continues until the earlier to occur of (1) the expiration of the Warranty Duration period, or (2) the Number of Operations, both as specified in the table below. If the Product is both purchased and installed within the United States or Canada, this Limited Warranty is granted to each end user of the Product who acquired the Product for its own use during the Warranty Period (“End User”). In all other situations, this Limited Warranty is granted only to the first purchaser of the Product (“Immediate Purchaser”) from SLLC. No primary or remote purchaser or owner of the Product who is not a Warranty Holder may claim any benefit under this Limited Warranty, or any remedial promise included in this Limited Warranty. SLLC shall, upon prompt written notice from the Warranty Holder, correct a nonconforming Product by repair or replacement at the sole discretion of SLLC of the nonconforming Product or any part or component of a nonconforming Product necessary in SLLC’s discretion to make such Product conforming. Any transportation charges, labor for removing, reinstalling the Product or part, and/or costs related to providing access to the Product shall be the responsibility of the Warranty Holder. Correction in this manner will constitute the Warranty Holder’s exclusive remedy and fulfillment of all SLLC’s liabilities and responsibilities hereunder. SLLC’s duty to perform under this limited warranty may be delayed, at SLLC’s sole option, until SLLC has been paid in full for all products purchased by the Warranty Holder. No such delay will extend the Warranty Period. If SLLC does not make such repair or replacement, SLLC’s liability for damages on account of any claimed nonconformity will in no event exceed the purchase price of the Product in question. This Limited Warranty does not apply to any Product that has been disassembled, repaired, or altered by anyone other than SLLC. This Limited Warranty will not apply to any Product that has been subjected to improper or abnormal use of the Product. SLLC has no responsibility to repair or replace any Product or component thereof manufactured by another party, but SLLC will assign, to the extent assignable, to the Warranty Holder any manufacturers’ warranty that applies to products and components not manufactured by SLLC.

THIS LIMITED WARRANTY IS EXCLUSIVE AND IN LIEU OF ALL OTHER WARRANTIES. THERE ARE NO OTHER EXPRESS, IMPLIED, OR STATUTORY WARRANTIES. ALL IMPLIED WARRANTIES WHICH MAY ARISE BY IMPLICATION OF LAW, OR APPLICATION OF COURSE OF DEALING OR USAGE OF TRADE, INCLUDING, BUT NOT LIMITED TO, IMPLIED WARRANTIES OF MERCHANTABILITY OR FITNESS FOR A PARTICULAR PURPOSE, NONINFRINGEMENT OR OTHERWISE ARE EXPRESSLY EXCLUDED. SLLC SHALL NOT BE LIABLE OR RESPONSIBLE FOR ANY CONSEQUENTIAL, INCIDENTAL, INDIRECT, EXEMPLARY, SPECIAL, OR PUNITIVE DAMAGES, EVEN IF SLLC HAS BEEN ADVISED OF THE POSSIBILITY OF SAME. THE WARRANTY HOLDER IS SOLELY RESPONSIBLE FOR THE SUITABILITY OF THE PRODUCT FOR ANY PARTICULAR APPLICATION.

Product Purchased Region	Product Installed Region	Warranty Holder	Warranty Duration
U.S and Canada	U.S and Canada	End User	Five (5) Years
All Other Conditions		Immediate Purchaser	Earlier of 1 year from installation or 18 months from shipment

Type EC-1V



Table of Contents

Chapter	Page
Table of Contents	V
List of Tables and Figures	VI
Summary & Introduction	1
Summary	1
Important	1
Introduction	2
Introduction	2
Ratings	3
Product Description	4
Typical Disconnect Switch	4
Receiving, Handling & Storage	5
Unpacking	5
Storage	5
Installation & Adjustment Procedures	6
Recommended Tools & Values	6
General Information & Mandatory Pre-Installation Requirements	6
Preferred Switch Assembly Method	7
Installation of the EC-1V When Shipped Unassembled	9
Contact Misalignments	12
Insulator Preload	14
Operating Mechanism (See Operating mechanism drawings provided for details)	15
Final Switch Adjustments (Tuning)	16
Changing Disconnect Opening Direction	21
Recommended Inspection Maintenance	23
Recommended Inspection and Maintenance	23
Patrolling Inspection (6 Months)	23
Routine Inspection and Maintenance (5 year)	23
Periodic Inspection and Maintenance (10 year)	23
Inspection Checklist	24

List of Tables and Figures

Tables	Page
Table 1: Ratings Table	3
Table 2: Recommended Tools and Torque Values	6
Table 3: Recommended Installation and Maintenance Table.....	23

Figures	Page
Figure 1: Typical EC-1V Switch Pole Assembled & Common Terminology.....	4
Figure 2: Contact Assembly.....	7
Figure 3: Attach Arcing Horns as Shown	8
Figure 4: Insulator Bearing Components	9
Figure 5: Jack Screws	11
Figure 6: Proper Contact Alignment.....	12
Figure 7: Misalignment "A".....	12
Figure 8: Misalignment "B".....	12
Figure 9: Misalignment "C"	13
Figure 10: Misalignment "D"	13
Figure 11: Misalignment "E".....	13
Figure 12: Preload Insulators.....	14
Figure 13: Typical Operating Mechanism	15
Figure 14: Typical Operating Arrangement	16
Figure 15: Type HOGO (High Output Geared Operator) Front View.....	17
Figure 16: Type SEGO (Safety Enhanced Gear Operator) Front View	18
Figure 17: Adjustable Arm Assembly.....	19

Summary & Introduction

Summary & Introduction

Summary

These instructions do not intend to cover all details or variations in equipment, or provide for every possible contingency to be met in connection with installation, operation or maintenance. Should information be desired or should particular problems arise which are not covered sufficiently for the purchaser's purposes, the matter should be referred to the local Southern States Representative.

The contents of this instruction manual should not become part of or modify any prior or existing agreement, commitment or relationship. The sales contract contains the entire obligations of Southern States. The Warranty contained in the contract between the parties is the sole warranty of Southern States. Any statements contained herein do not create new warranties or modify the existing warranty.

Important

The information contained herein is general in nature and not intended for specific application purposes. It does not relieve the user of responsibility to use sound practices in application, installation, operation, and maintenance of the equipment purchased. Southern States reserves the right to make changes in the specifications shown herein or to make improvements at any time without notice or obligations. Should a conflict arise between the general information contained in this publication and the contents of drawings or supplementary material, or both, the latter shall take precedence.

Summary & Introduction

Introduction

Southern States Type EC-1V is a three phase, group operated, center break “vee” air disconnect switch constructed primarily of high strength aluminum. Applications for these switches included disconnecting and sectionalizing of lines, and isolating or bypassing other electrical equipment. Poles can be mounted in a horizontal “upright,” vertical, or under-hung position. The switch can be operated using a manual operator or electrical motor operator (Operating Mechanism).

For easy installation, all models use jack screws which provide infinite adjustments and eliminate time consuming shimming of insulator stacks.

The installation procedure for all mounting positions and operating schemes is similar and explained herein. A system of pipes, bearing, and adjustable length arms is utilized to open and close the switch from a ground level operator.

The instructions contained within this manual are necessary for the safe installation, maintenance, and operation of the EC-1V switch. A qualified person, familiar with this of type equipment, should carefully read and follow the instructions.

These instructions are intended to provide a general guideline for the installation, adjustment, and maintenance of the EC-1V switch. It is not possible to cover all details, equipment variations, and potential conditions. Contact Southern States, LLC in the event conditions associated with a specific application are not sufficiently addressed.

All photographs and sketches in this manual are for illustration purposes only and may not be to scale. Refer to the Unit Assembly drawing or the Operating Mechanism drawing provided with each disconnect switch for specific details. During installation, it may be necessary to make adjustments other than those described in this manual. Contact your local representative or the factory if questions should arise.

Southern States After Sales and Service Department is available for field installation assistance along with providing parts support for all Southern States products.

Contact After Sales and Service at 770-946-4562, 7:30am-4:00pm EST Monday-Friday.
After Hours: 770-946-4565

Distinctive signal words are used to indicate the degree of hazard that may be encountered by the user. Identification of the signal words and their definition follow:

▲ DANGER

Indicates an imminently hazardous situation, which, if not avoided, will result in death or serious injury.

▲ CAUTION

Indicates a potentially hazardous situation, which, if not avoided, may result in minor or moderate injury. It may also be used to alert against unsafe practices.

▲ WARNING

Indicates a potentially hazardous situation, which, if not avoided, could result in death or serious injury.

Summary & Introduction

Ratings

Table 1: Ratings Table

RATINGS					
Maximum Voltage Rating (kV)	72.5	123	145	170	245
BIL (kV)	350	550	650	75	900
Rated Power Frequency	60 Hz				
Continuous Current	1200 A	2000 A – 3000 A		3000 A – 5000 A	
Short-Time Symmetrical Withstand (3 Sec.)	38 kA RMS	63 kA RMS		80 kA RMS	
Peak Withstand	99 kA	164 kA		208 kA	
Ambient Temperature Rating	-40°C to +50°C Standard -50°C Optional				

Product Description

Typical Disconnect Switch

In general, installing a disconnect switch consists of the following:

- Mounting the insulators to the switch base (**B**) (Refer to **Preferred Switch Assembly Method**, page 7).
- Mounting the live parts (**A**) to the insulators.
- Mounting the switch base (**B**) to the structure (Refer to the **Operating Mechanism Drawings** for structure and mounting details)
- Installing operating mechanism components
- Final adjustment or tuning (Refer to **Final Switch Adjustments (Tuning)**, page 16).

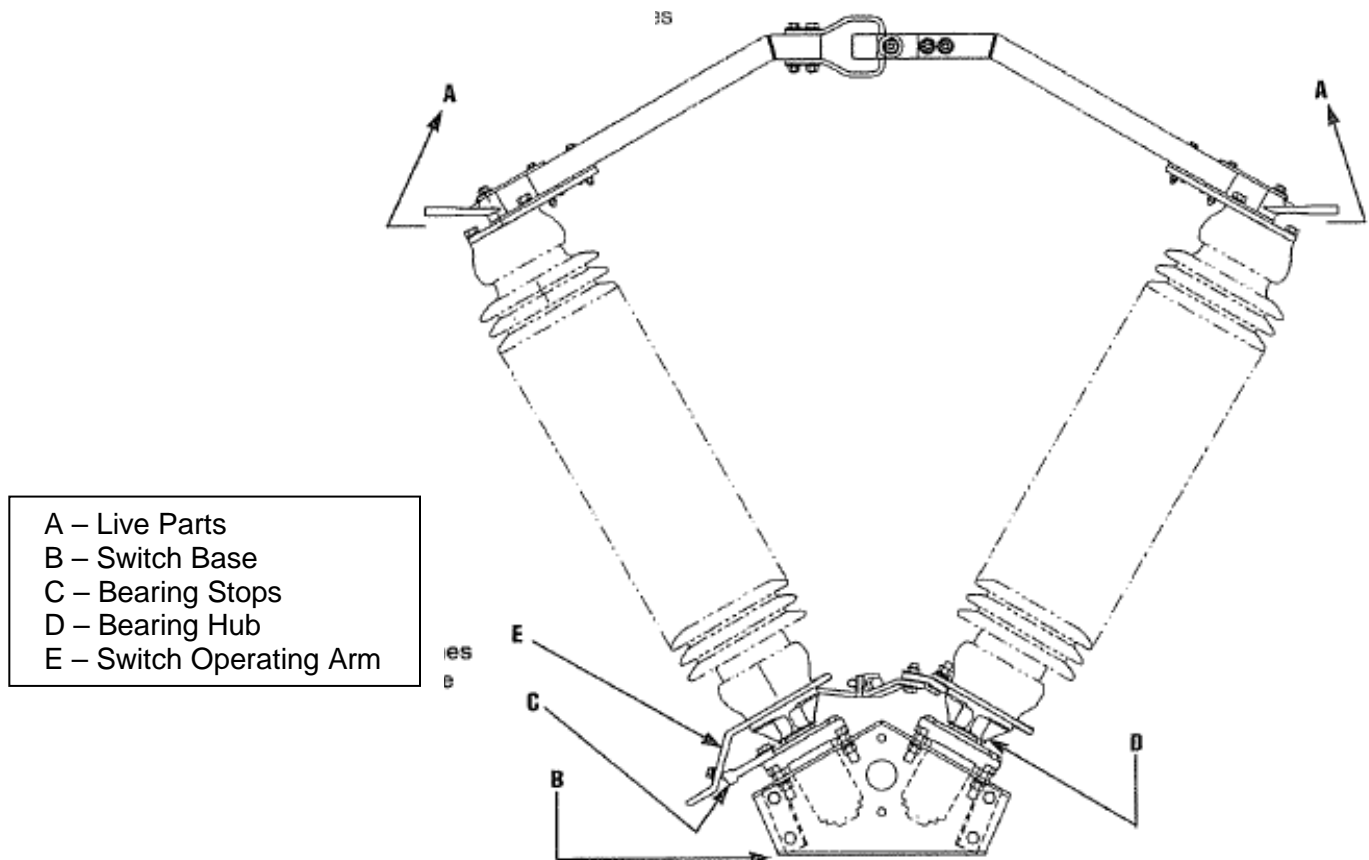

Figure 1: Typical EC-1V Switch Pole Assembled & Common Terminology
(123kV, 1200 amp shown.)

Receiving, Handling & Storage

Receiving, Handling & Storage

▲ CAUTION These switches are top-heavy and unstable unless bolted down. To prevent personnel injury or equipment damage, use extreme care when uncrating.

Unpacking

Unpack the equipment and check for damages or material shortages immediately. The bill-of-material from the Unit Assembly (switch) and Operating Mechanism drawings should be used for this purpose. If damage or a shortage is noted, file a claim immediately with the carrier and contact the factory.

Storage

All components of the EC-1 aluminum center side break disconnect switch are suitable for outdoor use and do not have any special storage requirements. Keep bearings out of standing water. Keep upright and support live parts with base. If a motor operator is furnished, be sure to connect the heater circuit using the provided external wiring, while the unit is in storage. Discard the wiring upon installation.

Typical crating is intended for storage less than 1 year. If long term storage is required please notify factory at time of order placement so that special crating can be used.

Installation & Adjustment Procedures

Installation & Adjustment Procedures

Recommended Tools & Values

Table 2: Recommended Tools and Torque Values

Recommended Tools		Recommended Torque Values	
Type	Sizes	Bolt/Nut size	Torque (Ft-lb)
Hand Wrenches and/or Sockets	15/16", 3/4", 5/8", 9/16"	1/2"	50 (S. Steel) 40 (All Others)
Drill Bit	1/4"	5/8"	92
		3/4"	127
		1"	286

General Information & Mandatory Pre-Installation Requirements

All photographs and sketches in this manual are for illustration purposes only and may not be to scale. Refer to the Unit Assembly drawing or the Operating Mechanism drawing provided with each disconnect switch for specific details on switch opening direction and handle location(s). *During installation, it may be necessary to make adjustments other than those described in this manual.* Contact your local representative or the factory if questions should arise.

Southern States Service Department is available for field installation assistance along with providing parts support for all Southern States products.

Contact the Service Department at 770-946-4562.

Installation & Adjustment Procedures

Preferred Switch Assembly Method

The Type EC-1V center break Vee switch is normally shipped assembled on insulators. Control components are packed separately. Installation consists of mounting the switch pole on the structure and installing the operating linkage.

These instructions give the general procedure for adjusting EC-1V switches. It may be necessary to make adjustments not described in the manual. If any questions should arise concerning the installation or adjustment of its equipment, please call your local Southern States representative or the factory direct.

1. Prior to mounting preassembled switches on the structure, each pole should be thoroughly inspected for damage in shipment. If damage is noted, immediately file a claim with the carrier and notify the factory.
2. Assemble the switch pole on the ground and hoist it to the structure as a complete unit.

▲ CAUTION To prevent overturning during assembly, the switch base must be securely attached to a level, stable platform.

▲ CAUTION Lift fully assembled pole unit by the base only. **DO NOT lift the pole unit by the live parts.** Refer to Error! Reference source not found..

4. Test each switch pole for free operation and blade alignment. When closed, the blades should be in a straight line with the bearing stops touching (**Figure 2**). These stops can be adjusted if necessary.
5. After mounting the switch, shimming the base or other minor adjustments may be necessary.
6. **Using main sling attachment to the switch base only** and auxiliary sling attachment to keep the switch upright, mount the switches on the structure as shown on the plan view of the operating mechanism drawing. Be sure to orient each pole with the switch operating arm in the proper position. When lifting, positively lock the switch closed. This can be done by using clamps, wire, or straps to keep the switch operating arm ("E" on **Figure 1**) hard against the bearing stop.
7. When switch is mounted on the structure AND conductors are attached to terminal pads, check each pole for proper contact. Switch blades must come together with the male blade contact touching (not jamming) or within 1/16" of the blade stop in the female contact assembly.

If necessary, adjust the jack screws as described under "Contact Misalignments" in the following section.

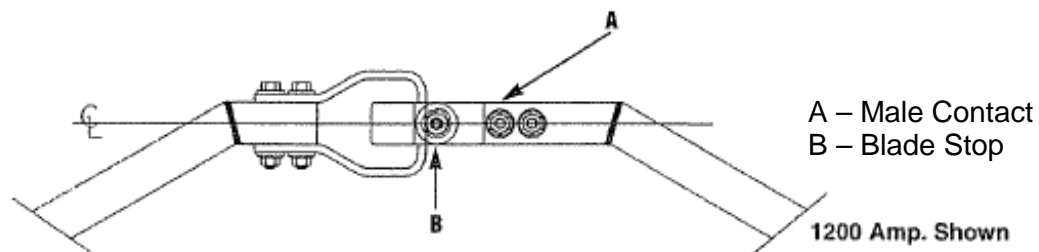

Figure 2: Contact Assembly

Installation & Adjustment Procedures

8. Preload the insulator as described under “Insulator Preload” in the following section.
9. If arcing horns are used, refer to **Figure 3** and the unit assembly drawing for installation. Arcing horns should rub against the male contact with enough pressure to maintain contact but not so hard as to cause binding. The horns can be bent if necessary to achieve proper contact.

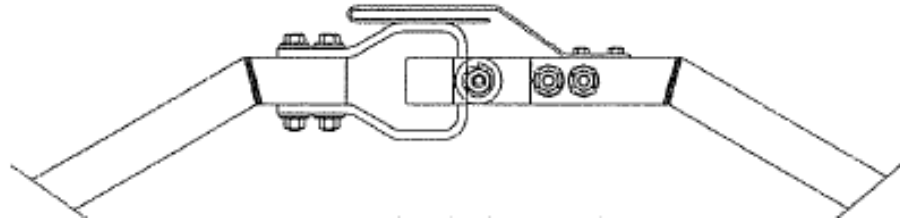

Figure 3: Attach Arcing Horns as Shown

Installation & Adjustment Procedures

Installation of the EC-1V When Shipped Unassembled

1. Prior to assembly, all components should be checked for any obvious damage in shipment. If damage is noted, immediately file a claim with the carrier and notify the factory.
2. The preferred method of field assembly is to bolt the switch base directly to its mounting structure and assemble the switch in place. Refer to the operating mechanism and the unit assembly drawing to ensure proper positioning of the base.
 - An alternative method is to assemble the switch on the ground and hoist to structure as a completely assembled unit. To do this:
 - Bolt the base to a firm, level surface sturdy enough to prevent overturn. These switches are top-heavy and very unstable. To prevent possible personal injury or equipment damage, select an assembly surface that will prevent overturn in both planes, end-to-end and side-to-side.
3. Refer to the unit assembly drawing. Check jack screw dimensions for proper height. Be certain that all four jack screws on each bearing are set correctly. Tighten jam nuts securely.
4. To install insulators, refer to the unit assembly drawing for proper orientation of parts. Only one set of bearing stops (positioned on control end of base) is used. Position switch arm directly on hub of bearing with bearing stops. Place an intrapole arm on top, being careful to set at proper angle with respect to the switch arm when against the bearing stop. Bolt insulators directly to the intrapole arm plate (**Figure 4**).

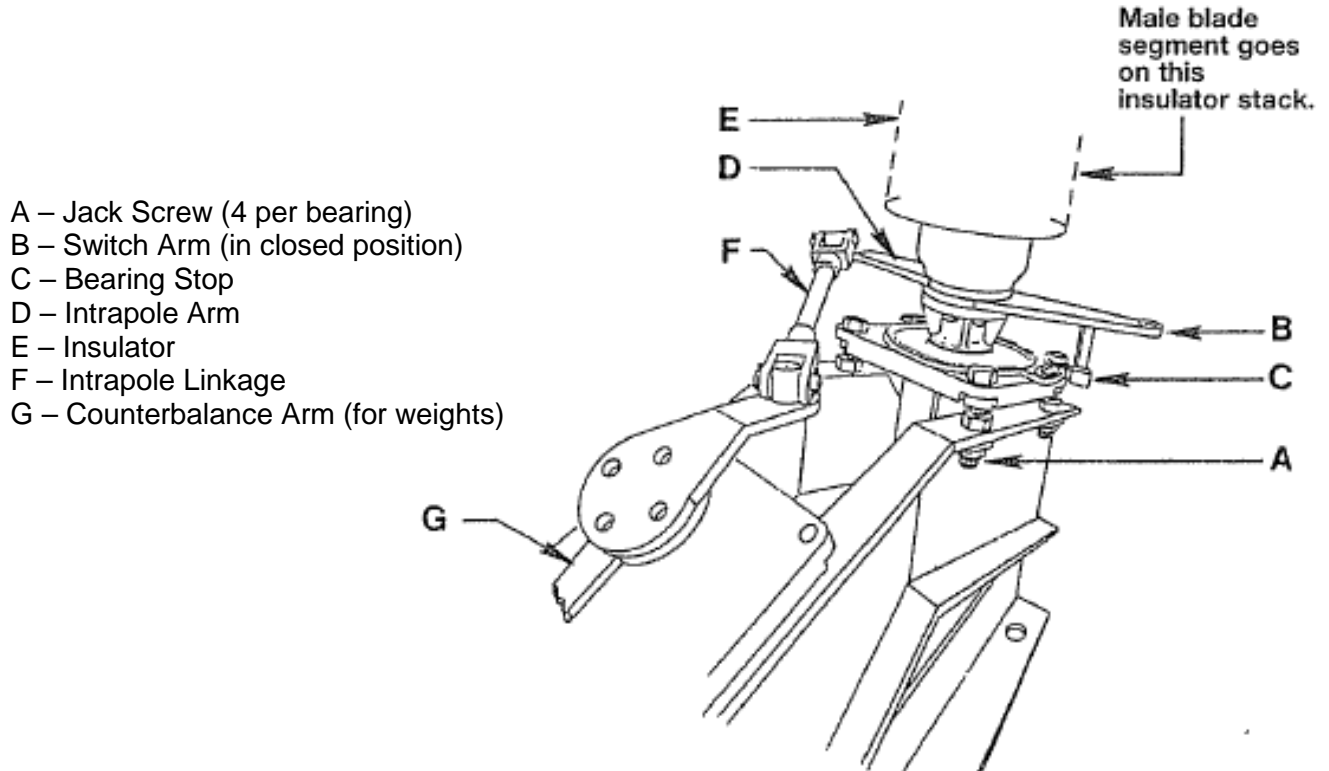

Figure 4: Insulator Bearing Components

Installation & Adjustment Procedures

5. Place counterbalance arm directly on the other bearing hub and other intrapole arm on top. Be certain the angle between the two arms is set correctly. Bolt insulators directly to the intrapole arm plate.

NOTE: Field assembly of switches with multiple unit insulator stacks is easier when the lowest unit is mounted first and balance of units mounted to it rather than mount the entire stack as a single unit.

6. Rotate insulator with switch arm clockwise (facing down) against the stop and attach intrapole linkage. Be sure length of this linkage is properly set to dimension shown on drawing.
7. Depending upon its application, this type switch will be counterbalanced either by weight or by spring. Refer to unit assembly drawing and attach appropriate number of weights – or the spring – to the counterbalance.
8. On top of stack with the switch arm only, securely bolt the male blade assembly in line with length of the base.
9. On the other stack, securely bolt the female blade assembly. The switch will have to be opened slightly to do this.

Installation & Adjustment Procedures

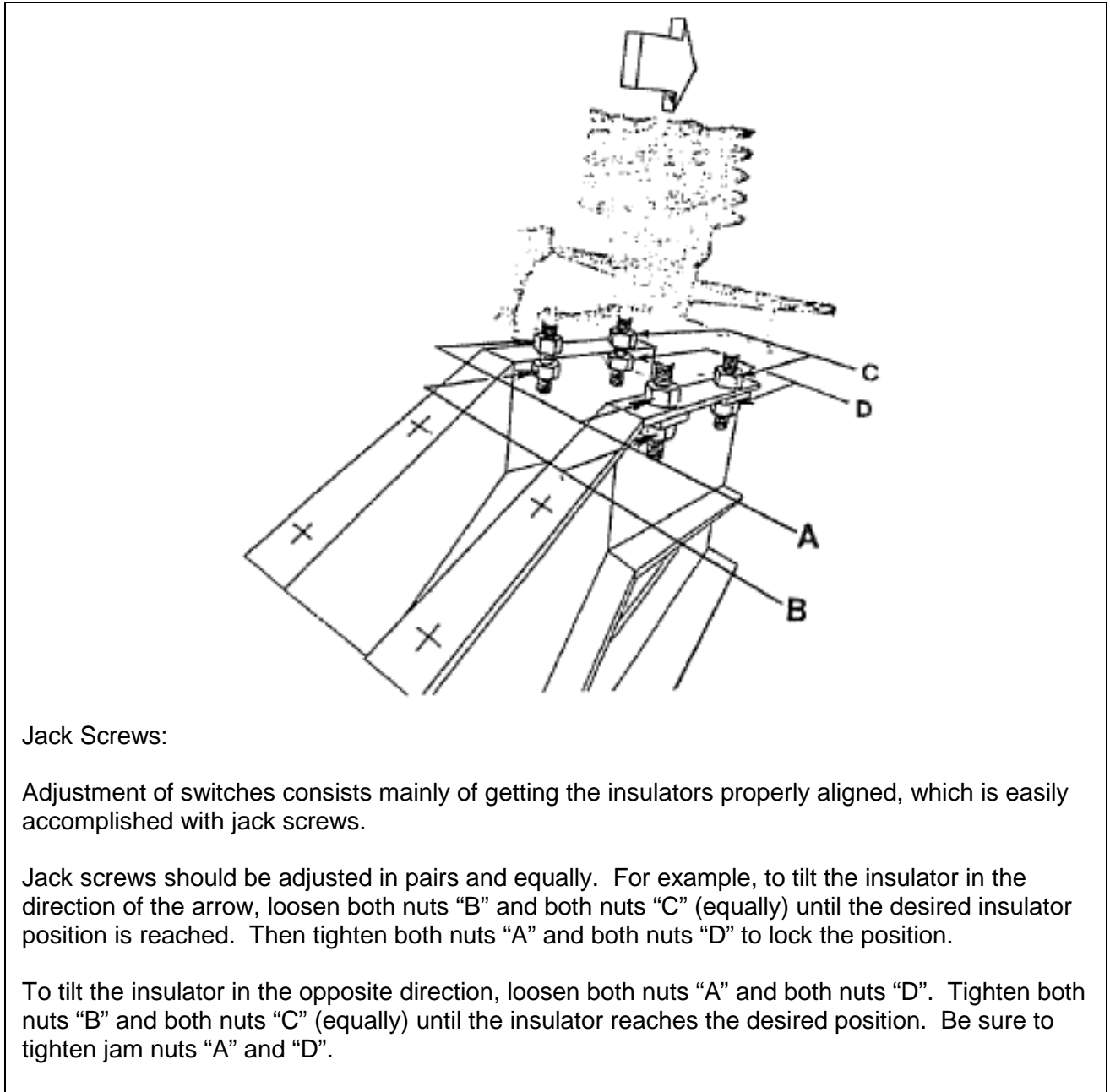

Jack Screws:

Adjustment of switches consists mainly of getting the insulators properly aligned, which is easily accomplished with jack screws.

Jack screws should be adjusted in pairs and equally. For example, to tilt the insulator in the direction of the arrow, loosen both nuts "B" and both nuts "C" (equally) until the desired insulator position is reached. Then tighten both nuts "A" and both nuts "D" to lock the position.

To tilt the insulator in the opposite direction, loosen both nuts "A" and both nuts "D". Tighten both nuts "B" and both nuts "C" (equally) until the insulator reaches the desired position. Be sure to tighten jam nuts "A" and "D".

Figure 5: Jack Screws

Installation & Adjustment Procedures

Contact Misalignments

Check for proper blade alignment. The blade segments should meet on centerline of base, on center of each other and the stop plug centered and touching (not jamming) the male contact stirrup (**Figure 6**).

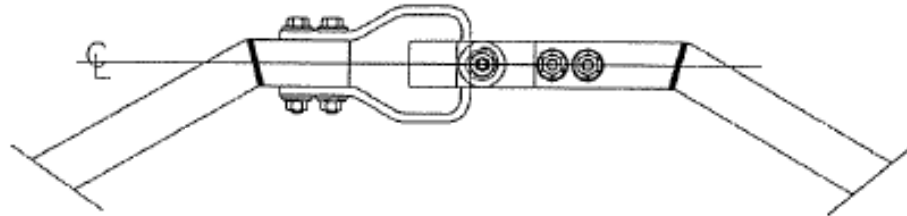

Figure 6: Proper Contact Alignment

There are three general types of blade misalignments correctable by jack screws and two correctable by linkage adjustments.

Field Assembly Note: Due to probable insulator stack deflection caused by conductor loads, the following adjustments will be pointless until the conductors are attached to both ends of the switch.

IMPORTANT: When adjusting jack screws, adjust each pair of jack screws equally (count the flats). This is to ensure the insulators will move along the centerline of the base in a straight line. See **Figure 5**.

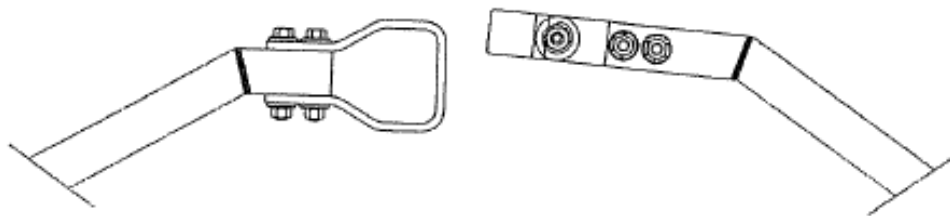

Figure 7: Misalignment "A"

- A. **Misalignment "A":** Jack the left insulator to the left and the right insulator to the left until the stop plug is centered on the stirrup. Adjust insulators one at a time and in equal increments.

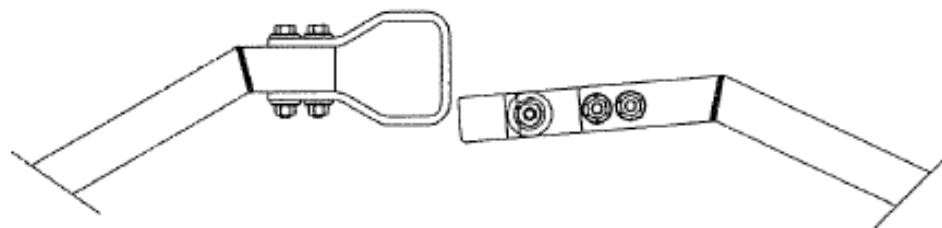

Figure 8: Misalignment "B"

- B. **Misalignment "B":** Jack the left insulator to the right and the right insulator to the right until the stop plug is centered on the stirrup. Adjust insulators one at a time and in equal increments.

Installation & Adjustment Procedures

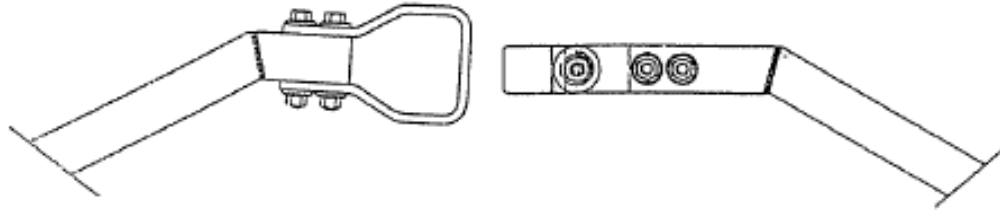

Figure 9: Misalignment “C”

- C. **Misalignment “C”**: Jack insulators toward each other – one at a time and in equal increments – until stop plug is centered on the stirrup.

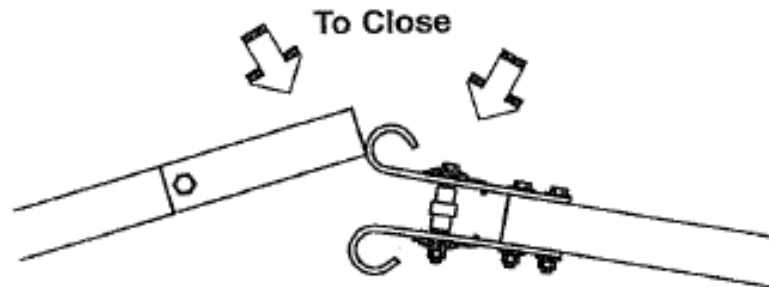

Figure 10: Misalignment “D”

- D. **Misalignment “D”**: The stirrup striking the trailing edge of the female contact is the result of the intrapole linkage being too short. Lengthen this linkage as required for smooth closing without interference or dragging.

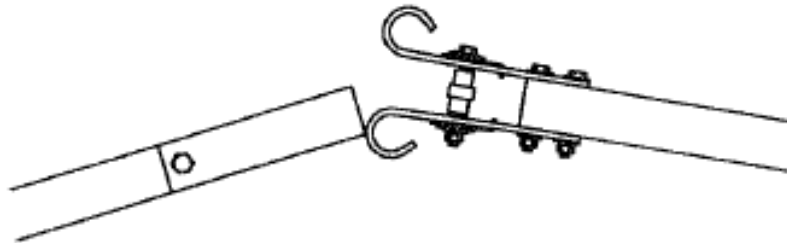

Figure 11: Misalignment “E”

- E. **Misalignment “E”**: The stirrup strikes the **leading** edge of the female contact. Shorten the linkage to correct this condition.

Installation & Adjustment Procedures

Insulator Preload

1. When the contact engagement is correctly set, preload the insulators toward the center of the gap. Add one flat on both outside jack screw nuts and subtract one flat on both inside nuts (**Figure 12**). This is done on both bearings.

To add, turn the nuts clockwise (facing down). To subtract, turn the nuts counter-clockwise.

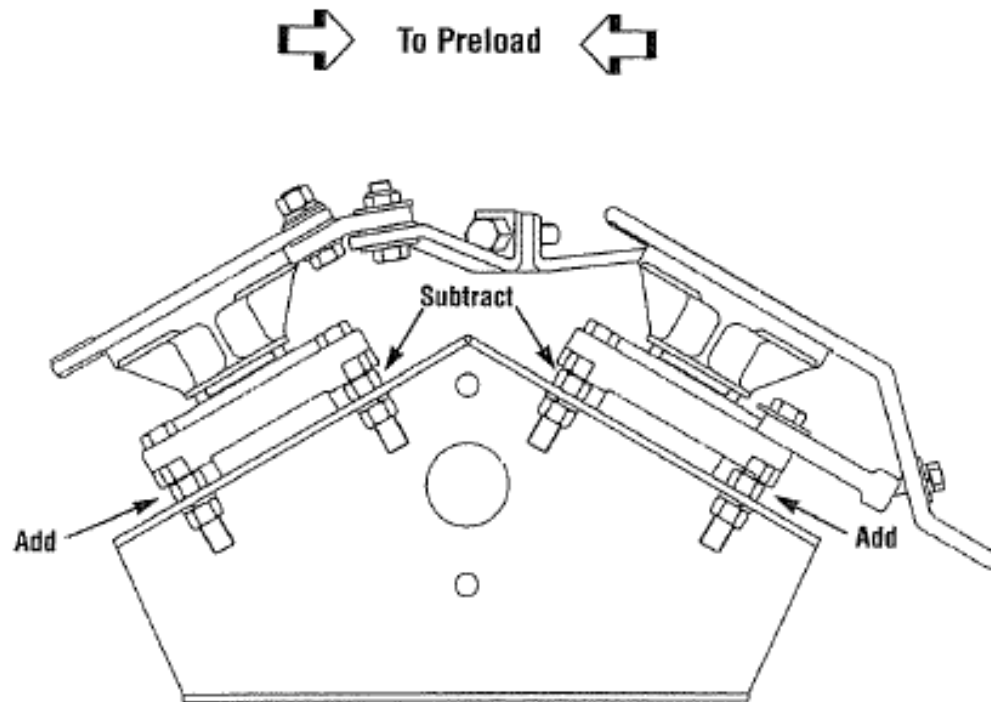
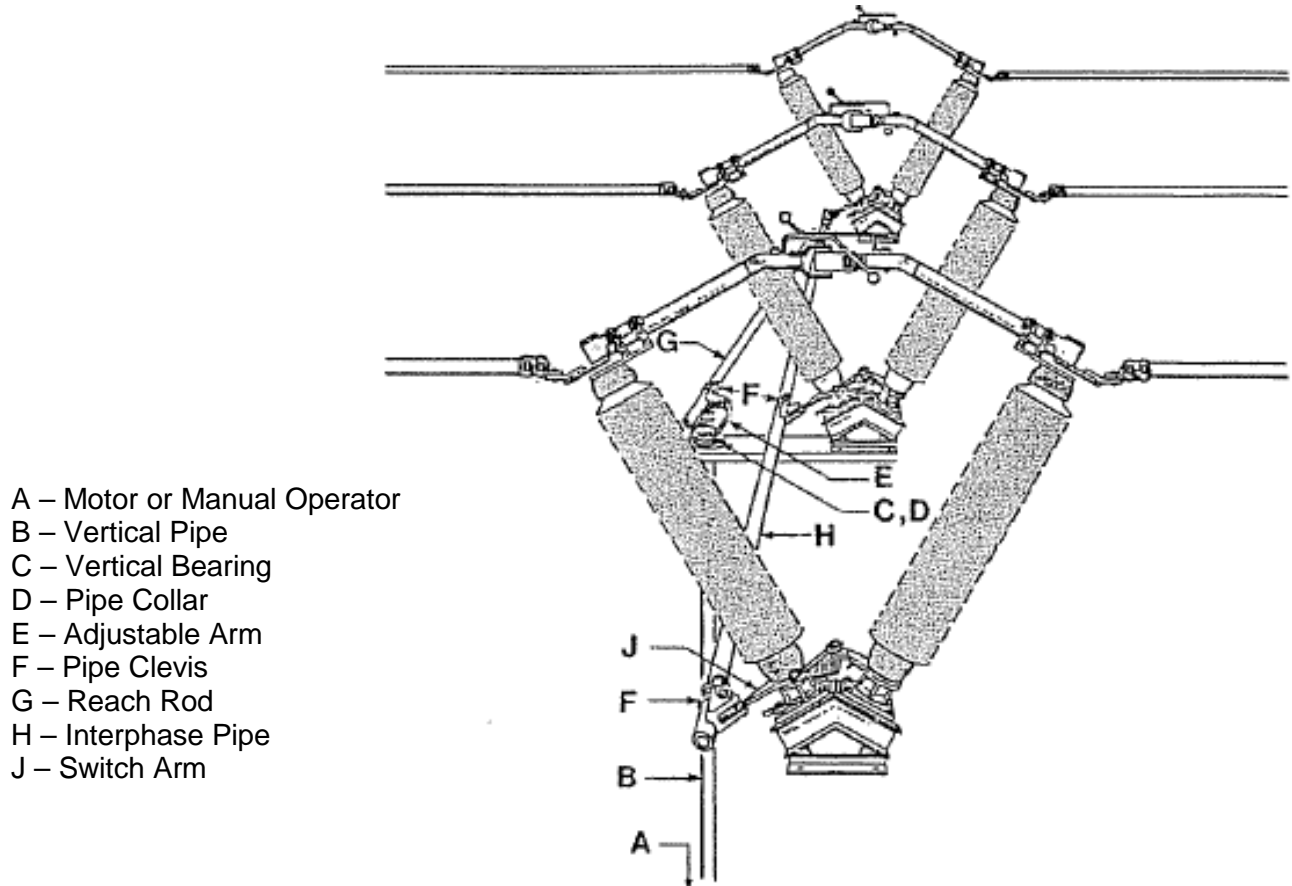

Figure 12: Preload Insulators

2. **Field Assembly** – If arcing horns are used, refer to the unit assembly drawing and Figure 3, and bolt on this equipment.
3. **Field Assembly** – Install operating mechanism components as directed on the following pages.

Installation & Adjustment Procedures

Operating Mechanism (See Operating mechanism drawings provided for details)



- A – Motor or Manual Operator
- B – Vertical Pipe
- C – Vertical Bearing
- D – Pipe Collar
- E – Adjustable Arm
- F – Pipe Clevis
- G – Reach Rod
- H – Interphase Pipe
- J – Switch Arm

Figure 13: Typical Operating Mechanism

1. Lay out all Operating Mechanism parts and check them against the Op-Mech drawing bill-of-materials.
2. To ensure that the bearing stops do not interfere with switch adjustments, loosen all open/close bearing stops, and slide them out of the way.
3. Refer to the Operating Mechanism drawing, and install all mounting brackets, bearings, bushings, pipe clevises, switch operating device, adjustable arm, reach rod, and other necessary components. Refer to **Figure 13**.

▲ CAUTION The pipe collar (above the vertical bearing) must support the entire weight of the vertical operating pipe. To prevent unnecessary component damage, **do not allow the pipe to rest on the switch operating device**. Refer to **Figure 14**.

4. While installing the pipes and clevises that have piercing bolts/set screws, do not pierce the pipe until instructed. Tighten the piercing bolts such that they grip the pipe until all adjustments are made.

Installation & Adjustment Procedures

5. After mounting all op-mech components, match-mark all clevis connections, the adjustable arm, and the switch operating devices' coupling, so that any slippage occurring during trial operations can be readily detected. Refer to **Figure 14**.

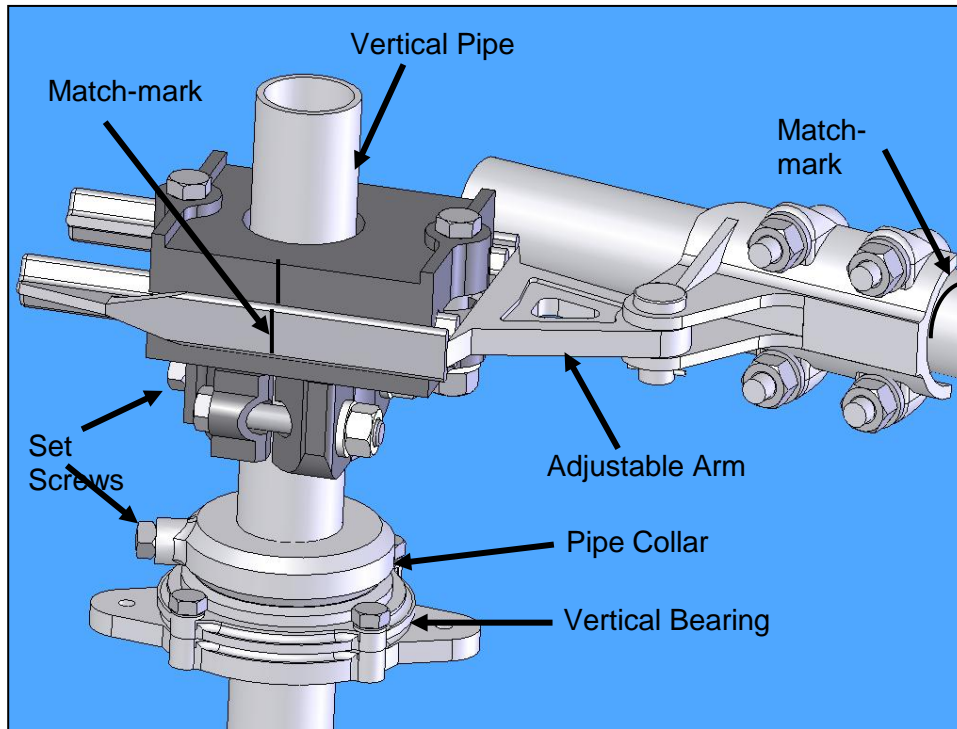

Figure 14: Typical Operating Arrangement

Final Switch Adjustments (Tuning)

1. The operating mechanism is intended to fully open and fully close the disconnect switch by rotating the vertical operating pipe about 180° using an operator (manual or electrical). The interphase pipe controls the individual operation of each switch pole, using a push/pull control. The reach rod translates the motion of the vertical operating pipe to the interphase linkage. The adjustable arm controls the total amount of switch operation available.

HINT: For easiest adjustment start with the reach rod connected to the drive phase and the interphase pipe disconnected from the other two phases. Once the drive phase is properly adjusted, connect the interphase pipe and continue tuning the other two phases, one at a time.
2. Switch Operating Devices:
 - 2.1. Worm gear operator (HOGO – High Output Geared Operator) (Optional)
 - 2.1.1. The weight of the vertical operating pipe should be supported by pipe collar (**Figure 14**) by maintaining the 1/4" - 3/8" gap (**Figure 15**).

Installation & Adjustment Procedures

2.1.2. When the switch is properly adjusted the operator handle should hang freely in both the open and closed positions to permit the use of a customer supplied padlock. Refer to **Figure 15**.

▲ CAUTION Be aware that there is an adjustable stop on the operator. **Do not over operate as damage will occur to the operator.**

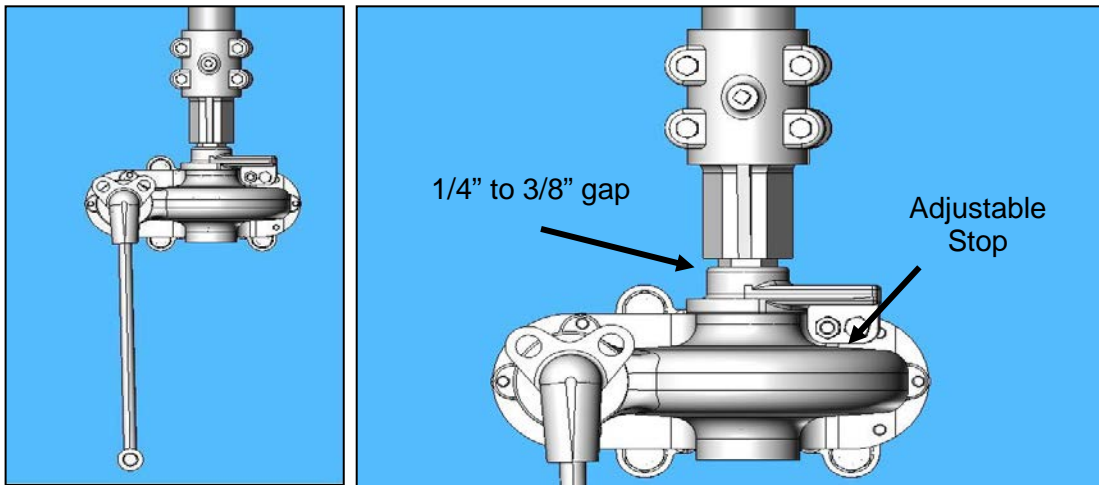

Figure 15: Type HOGO (High Output Geared Operator) Front View

Installation & Adjustment Procedures

- 3.1. Worm gear operator (SEGO – Safety Enhanced Gear Operator) (Optional)
 - 3.1.1. The weight of the vertical operating pipe should be supported by pipe collar by maintaining the 1/4"-3/8" gap.
 - 3.1.2. When the switch is properly adjusted the operator handle should hang freely in both the open and closed positions to permit the use of the customer supplied padlock.

⚠ CAUTION Be aware that there is an adjustable stop on the operator. Do not over operate as damage will occur to the operator.

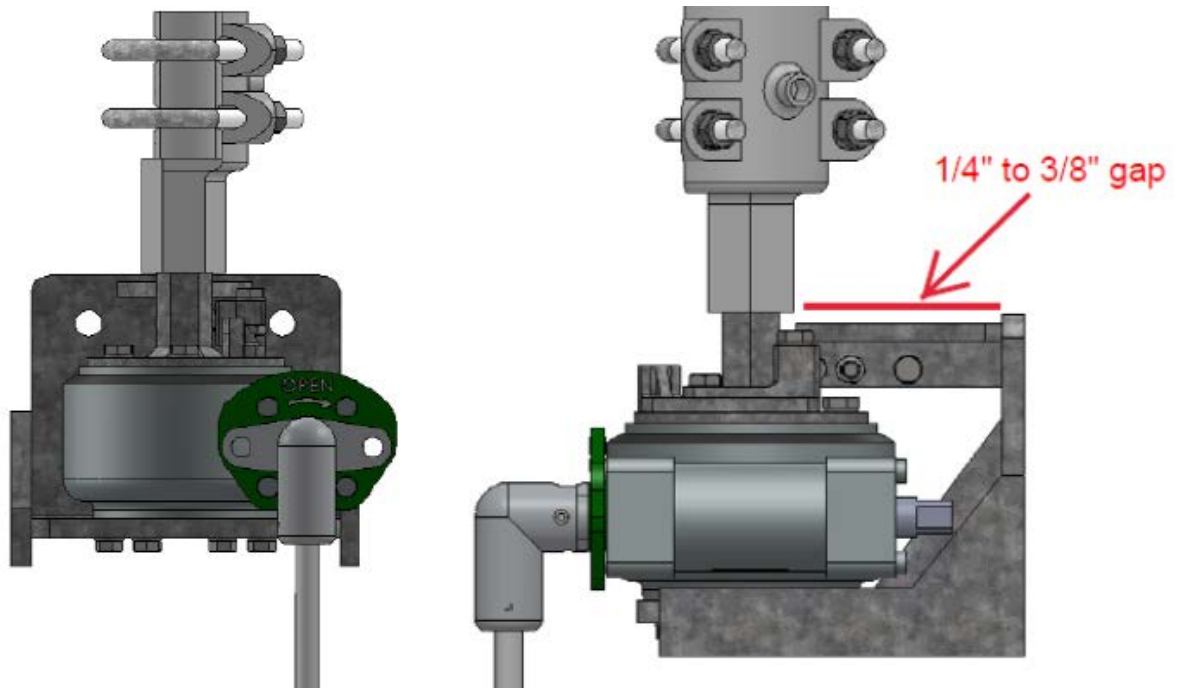

Figure 16: Type SEGO (Safety Enhanced Gear Operator)

Installation & Adjustment Procedures

- 2.2. Swing handle operator
 - 2.2.1. When the switch is properly adjusted the handle should hang vertically and free in both the open and closed positions to permit the use of a customer supplied padlock.
- 2.3. Electrical motor operator
 - 2.3.1. Please refer to motor operator instruction manual for proper installation and setup.
 - 2.3.2. Use manual operation while completing switch setup.
 - 2.3.3. **Do not** electrically operate until all switch adjustments are complete. **ALWAYS** operate the motor operator decoupled first to ensure proper setup.
3. Preliminary Switch Settings:
 - 3.1. Start with the disconnect switch and operating mechanism in the closed position.
 - 3.1.1. The switch is in the fully closed position when the centerline of the male blade assembly is aligned with the centerline of the Female Blade Assembly.
 - 3.2. Set the adjustable arm to the preliminary setting on the Operating Mechanism drawing, adjustment may be necessary to achieve proper operation.
 - 3.3. Be sure that all stops have been loosened to prevent binding during test operations.
4. Final Adjustment:
 - 4.1. Before making any adjustments always check that none of the pinned joints have slipped. If slippage occurs, correct it and repeat the operation to verify that adjustment is really needed.
 - 4.2. Open the disconnect switch with the operator. The switch is in the fully open position when both blades are approximately 90° to the switch base.
 - 4.3. If the switch **does not** fully open before the operator reaches the fully open position, the adjustable arm radius is too short. Close the switch, match-mark the adjustable arm and the pipe clevis, and loosen the bolts on the adjustable arm and pipe clevis. **Lengthen the adjustable radius arm approximately 1/4". Allow the pipe clevis to reposition itself the same 1/4".** Refer to **Figure 15**. Test operation and readjust as necessary.

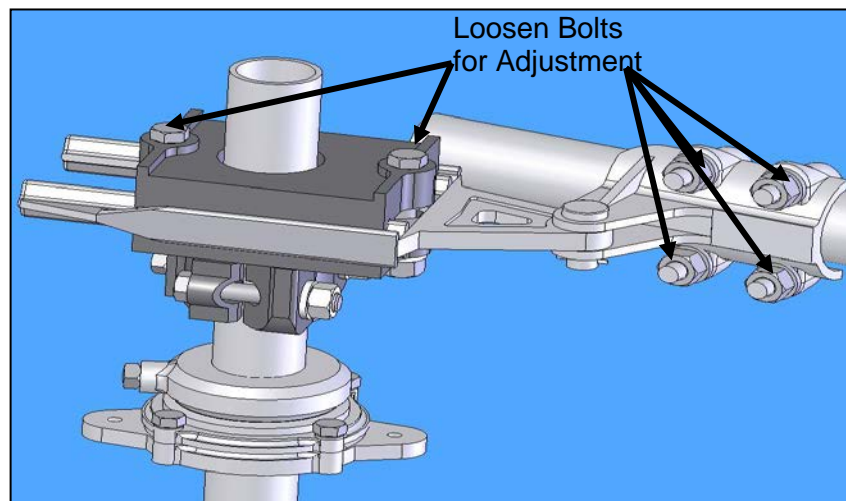

Figure 17: Adjustable Arm Assembly

Installation & Adjustment Procedures

- 4.4. If the switch is fully open before the operator reaches the fully open position, the adjustable arm radius is too long. Close the switch, match-mark the adjustable arm and the pipe clevis, and loosen the bolts on the adjustable arm and pipe clevis. **Shorten the adjustable radius arm approximately 1/4". Allow the pipe clevis to reposition itself the same 1/4".** Refer to **Figure 15**. Test operation and readjust as necessary.
- 4.5. If the switch has too much toggle in either open or closed position, loosen the pipe clevis and adjust to allow for an equal toggle amount in both positions.
- 4.6. All poles of the fully adjusted disconnect switch should operate together, although a slight variance between poles is acceptable. The primary objective is for all poles to fully open and fully close. Minor adjustments of the inter-phase pipe clevises may be necessary for pole coordination.
- 4.7. Setting Toggle:
 - 4.7.1. Toggle is obtained when the switch is in the either fully open or fully closed position and the connection point between the adjustable arm and pipe clevis has gone past the centerline of the vertical operating pipe. The operating linkage will almost seem to snap past this point.
 - 4.7.2. If possible the switch should go into toggle in both the open and closed positions. This is not always possible, it is most important that the switch goes into toggle in the closed position, because this will help to prevent the disconnect switch from trying to open during a fault condition.
- 4.8. Final Check:
 - 4.8.1. Once all final adjustments are complete, be sure that all nuts are tightened to their specified torque (Refer to **Table 2**).
 - 4.8.2. Apply a minimal amount of grease to the point of each piercing bolt and then tighten the bolt until it pierces the pipe wall. For heavy walled pipe, (schedule 80 or above, 3" or above) pre-drill the piercing bolt holes with a piercing bolt drill guide (provided) and a 1/4" drill bit.
 - 4.8.3. Position bearing stops to lightly touch, in both the open and closed positions.

Installation & Adjustment Procedures

Changing Disconnect Opening Direction

The following are instructions for making field modifications to the opening direction of the disconnect switch if it is determined that it is necessary. If parts or assistance are required please contact your Local Representative or Southern States Service Division, contact information provide on the back page.

If disassembly is required by these instructions *IT SHOULD BE PERFORMED ON THE GROUND*. If this is not possible, proper safety and handling techniques must be used by installation crew to prevent damage to the components or injury to personnel.

1. Horizontally mounted disconnect switches without ground switch
 - 1.1. The simplest way to change disconnect opening direction is to rotate the **entire disconnect switch** and operating mechanism 180°. For visual reference to see what is affected simply rotate the operating mechanism 180° in your hand. You will notice that the operating linkage will rotate to the opposite end of the disconnect switch and that the operator will rotate to the opposite structure leg (diagonally from its original location).
 - 1.2. Sling each switch phase and rotate the entire assembly on the structure 180 degrees. Refer to Error! Reference source not found..
 - 1.3. The switch operator will also need to be relocated. There are 2 options:
 - 1.3.1. Move the operator to the opposite leg, diagonally from its original location. This is the best option as it allows for the original setup to be maintained.
 - 1.3.2. Maintain the operator on the same side of the structure. Assemble the components using the alternate position arrangement shown on the operating mechanism drawing. NOTE on 4 Column structures the operator will be on the same side of the structure, but it **MUST** move to the opposite end of the structure to obtain proper operation.
2. All other disconnect mountings without ground switch – PARTIAL DISASSEMBLY WILL BE REQUIRED
 - 2.1. Disconnect adjustment
 - 2.1.1. With the disconnect phase on the ground, open the switch by hand and secure the linkage in this position.
 - 2.1.2. Unbolt the female blade from the insulator. Place the blade in the closed position and reattach to the insulator. DO NOT move the switch linkage.
 - 2.1.3. Unbolt the male blade from the insulator. Place the blade in the closed position and reattach to the insulator. It will likely be necessary to allow the linkage to move toward the “new” OPEN direction to be able to reassemble.
 - 2.1.4. Minor adjustments maybe required to the operating rod to achieve proper open close operation as described in Section 2 above.
 - 2.2. Operator and Operating linkage adjustment
 - 2.2.1. Swing handle or Worm gear operator

NOTE: Due to space constraints you may not be able to move the adjustable arm to the opposite side of the pipe (structure side). In these cases it is impossible to achieve CLOCKWISE handle rotation to OPEN using a swing handle. The worm gear operator will have to be changed to achieve proper rotation. Please contact representative.

 - a. Leave the operator in the starting position as originally shown on the operating mechanism drawing.

Installation & Adjustment Procedures

- b. To achieve CLOCKWISE handle rotation to OPEN you must attach the adjustable arm 180 degrees from its original setup. The pipe clevis will also need to be rotated to the opposite side of the adjustable arm (side closest to the structure) but with the radius of the clevis still pointing toward the disconnect switch. The adjustable arm will now rotate toward the structure instead of away from it.
 - c. Attach all other items as shown in the operating mechanism drawing.
 - d. If the mechanism was originally setup for PUSH to OPEN it has now been changed to PULL to OPEN and vice versa.
3. Horizontally mounted disconnect switches with EVG-1 ground switch – PARTIAL DISASSEMBLY WILL BE REQUIRED. Please contact Local Representative or Southern States Service Division immediately. **New brackets for the ground switch and a new main switch operator will be required to make this change.**
 - 3.1. Disconnect adjustment
 - 3.1.1. With the disconnect phase on the ground, remove the ground switch and mounting bracket as a complete assembly.
 - 3.1.2. If the insulators have not been installed, unbolt the live parts from the switch bearings and flip the paddle arms on each bearing along the long axis of the switch base. Reinstall all items as described in **Preferred Switch Assembly Method**.
 - 3.1.3. If the insulators have been installed, unbolt the male and female blades from the insulator. Unbolt the insulators from the switch bearings and flip the paddle arms on each bearing along the long axis of the switch base. Reinstall all items as described in **Preferred Switch Assembly Method**.
 - 3.1.4. Minor adjustments maybe required to the operating rod to achieve proper open close operation as described in Section 2 above.
 - 3.2. Ground Switch Adjustment
 - 3.2.1. Rotate the ground switch jaw 180 degrees and reattach to disconnect blade.
 - 3.2.2. Install new support bracket to the switch base. The ground switch must be installed on the OPEN side of the disconnect. Adjust the jacking bolts on the bracket until ground switch fits properly into its jaw.
 - 3.3. Operator and Operating linkage adjustment
 - 3.3.1. Both operators must move to the opposite leg(s) of the structure directly across from their current position
 - 3.3.2. Operator
 1. Setup operating linkages as shown in revised operating mechanism drawings that will be provided.
 2. Please note that a new operator will be needed for the main switch. The ground switch operator is the same.

Recommended Inspection Maintenance

Recommended Inspection Maintenance

The EC-1V has been designed to operate with low maintenance. Periodic inspection is important for satisfactory operation. Frequency of inspection and maintenance depends on the installation site, weather and atmospheric conditions, experience of operating personnel and special operation requirements.

Table 3: Recommended Installation and Maintenance Table

		Installation Tests	Patrolling Inspection 6 month	Routine 5 Year *	Periodic 10 Year *
Insulators	Contamination	X	X	X	X
	Damage	X	X	X	X
Cabinet (if motor operator supplied)	Any loose parts on the floor of the cabinet?	X	X	X	X
	Wiring Secure	X	X	X	X
	Links Secure	X	X	X	X
	Inspect Mechanism for loose parts	X	X	X	X
	Heaters Energized	X	X	X	X
	Door Seal	X	X	X	X
	Mechanical	Operational Tests	X		X
Electrical	Contact Resistance	X		X	X
Liveparts Inspection	Inspect Contacts	X		X	X
	Inspect Arcing Horns	X		X	X

*Note: Harsh environments with excessive airborne contaminants, such as, salt spray and industrial pollutants will require inspection/maintenance every two (2) years.

For specific instructions please refer to the SCE disconnect maintenance guidelines.

Patrolling Inspection (6 Months)

The patrolling inspection is a largely visual inspection on an energized unit in service. The frequency of the inspection is determined by the local conditions and policies of the owner of the equipment. Refer to **Table 3** for recommended inspection items.

Routine Inspection and Maintenance (5 year)

Routine inspection is performed on a de-energized unit. The frequency of the inspection is determined by the local conditions and policies of the owner of the equipment. Refer to **Table 3** for recommended inspection items.

Periodic Inspection and Maintenance (10 year)

Periodic inspection is performed on a de-energized unit. The frequency of the inspection is determined by the local conditions and policies of the owner of the equipment. Refer to **Table 3** for recommended inspection items.

Recommended Inspection Maintenance

Inspection Checklist

245kV EC-1V TYPE DISCONNECTS			
SUBSTATION NAME		POSITION	
SITE REP:		DATE:	
ACCEPTED BY QC:		DATE:	
INSTALLER:			
SAP NUMBER:		KV RATING:	
S.S. #		AMP RATING:	
INSTALLATION PER SOUTHERN STATES MANUAL			
	Installer	Site Rep	OC
Check for damage or material shortages (Page 1)			
All Nuts, Bolts and other hardware are Tight and Torque marked			
Pipe Collar supporting Vertical Drive Pipe (Refer to 6.2.1.2 Page 13)			
All Cotter Keys are Bent			
Blades Centered in The Clip (Figure 6 Page 6)			
Blades Closed Gap 3/4" to 1/4" (Figure 6 Page 6)			
Blades Closed & Aligned (Refer to 2.2 on Page 6)			
Blades Straight In Open Position (Figure 17 Page 14)			
Verify Contact Wipe - Timing (within 3/4")			
Open rotation Stops Engaged On Insulator Stack (Figure 9 Page 7)			
Closed rotation Stops factory set no adjustment required (Figure 10 Page 8)			
Verify Min. Gap On HOGO Handle 1/4 to 3/8 gap (Figure 16 Page 13)			
Blade Lock adjusted per (Figure 14 Page 11)			
Handle is 40 inches from grade (+/-) 3 inches			
Handle is Hanging Free (Refer to 6.2.1.3. on Page 13)			
Handle - Clockwise to Open			
Handle and Structure Ground Attached			
Handle Stop Touching in The Closed Position			
Handle Stop Touching In The Open Position			
Handle operating pressure less than 35 pounds of force			
Name Plate attached by handle			
Signs- Open & Closed Properly Installed			
Toggle in Closed Position (Refer to 6.4.7 on Page 14)			
Toggle in Open Position (Refer to 6.4.7 on Page 14)			
HOLD Point contact QC 48 Hours notice			
Piercing Bolts Set After Buy-off			



The Quality Name in High Voltage Switching

30 Georgia Avenue
Hampton, Georgia 30228
Phone: 770-946-4562
Fax: 770-946-8106
E-mail: support@southernstatesllc.com
<http://www.southernstatesllc.com>

©2017 Southern States, LLC
IB-136-EC1V-R5 060217 Printed U.S.A.