



# **COLE TYPE P SCE EDITION**

Copper Center Break  
Disconnect Switch

For 72.5-245 kV Ratings

**INSTALLATION &**

**INSTRUCTION**

**MANUAL**



## Safety Information

### DANGER

IMPROPER HANDLING, INSTALLATION, OPERATION OR MAINTENANCE OF THIS EQUIPMENT MAY CAUSE IMMEDIATE HAZARDS WHICH WILL LIKELY RESULT IN SERIOUS PERSONNEL INJURY OR DEATH.

### WARNING

The equipment covered by this publication must be handled, installed, operated and maintained by qualified persons who have direct knowledge and experience dealing with the hazards involved and are thoroughly trained in the handling, installation, operation and maintenance of high voltage transmission and distribution equipment. These instructions are meant for only such **Qualified Persons**. They are not intended to be a substitute for adequate training and experience in safety procedures for this type of equipment.

A **Qualified Person** is one who is trained in and has skills necessary:

- to read and comprehend this instruction book – understanding that these instructions are general in nature
- to accept personal responsibility to prepare and maintain an intrinsically safe work environment and maintain control of the work site to safeguard all persons present
- to develop and implement a proper rigging, lifting, and installation plan along with all safety precautions required to insure safe and proper lifting and installation of the equipment.
- to distinguish between energized and non energized parts
- to determine proper approach distances to energized parts
- to properly work with and around energized or de-energized equipment that may be pressurized with gas
- for proper use of personal protective equipment, insulating and shielding materials, insulated tools for working near energized and /or pressurized electrical equipment
- to recognize and take necessary precautions for the unique and dynamic conditions of site and specialized equipment to maintain a safe work environment during handling, installation, operation, and maintenance of high voltage switching equipment

The instructions in this manual are general guidelines for this type of equipment and not specific to the equipment supplied. Portions of it may not be applicable or may not have complete instructions for your specific equipment.

If you do not understand any part of these instructions or need assistance, contact Southern States Service Division at 770-946-4562 during normal business hours (EST) or 770-946-4565 after normal business hours.

## LIMITED WARRANTY

Southern States, LLC (“SLLC”) warrants only to the Warranty Holder (hereinafter defined as the “End User” or the “Immediate Purchaser”, as applicable, pursuant to the terms and conditions of this Limited Warranty as set forth below), that the Product identified below will, upon shipment, be free of defects in workmanship and material for the applicable Warranty Period. The “Warranty Period” is that period of time during which this Limited Warranty is effective, and such period begins on the invoice date issued by SLLC for the Product, and continues until the earlier to occur of (1) the expiration of the Warranty Duration period, or (2) the Number of Operations, both as specified in the table below. If the Product is both purchased and installed within the United States or Canada, this Limited Warranty is granted to each end user of the Product who acquired the Product for its own use during the Warranty Period (“End User”). In all other situations, this Limited Warranty is granted only to the first purchaser of the Product (“Immediate Purchaser”) from SLLC. No primary or remote purchaser or owner of the Product who is not a Warranty Holder may claim any benefit under this Limited Warranty, or any remedial promise included in this Limited Warranty. SLLC shall, upon prompt written notice from the Warranty Holder, correct a nonconforming Product by repair or replacement at the sole discretion of SLLC of the nonconforming Product or any part or component of a nonconforming Product necessary in SLLC’s discretion to make such Product conforming. Any transportation charges, labor for removing, reinstalling the Product or part, and/or costs related to providing access to the Product shall be the responsibility of the Warranty Holder. Correction in this manner will constitute the Warranty Holder’s exclusive remedy and fulfillment of all SLLC’s liabilities and responsibilities hereunder. SLLC’s duty to perform under this limited warranty may be delayed, at SLLC’s sole option, until SLLC has been paid in full for all products purchased by the Warranty Holder. No such delay will extend the Warranty Period. If SLLC does not make such repair or replacement, SLLC’s liability for damages on account of any claimed nonconformity will in no event exceed the purchase price of the Product in question. This Limited Warranty does not apply to any Product that has been disassembled, repaired, or altered by anyone other than SLLC. This Limited Warranty will not apply to any Product that has been subjected to improper or abnormal use of the Product. SLLC has no responsibility to repair or replace any Product or component thereof manufactured by another party, but SLLC will assign, to the extent assignable, to the Warranty Holder any manufacturers’ warranty that applies to products and components not manufactured by SLLC.

THIS LIMITED WARRANTY IS EXCLUSIVE AND IN LIEU OF ALL OTHER WARRANTIES. THERE ARE NO OTHER EXPRESS, IMPLIED, OR STATUTORY WARRANTIES. ALL IMPLIED WARRANTIES WHICH MAY ARISE BY IMPLICATION OF LAW, OR APPLICATION OF COURSE OF DEALING OR USAGE OF TRADE, INCLUDING, BUT NOT LIMITED TO, IMPLIED WARRANTIES OF MERCHANTABILITY OR FITNESS FOR A PARTICULAR PURPOSE, NONINFRINGEMENT OR OTHERWISE ARE EXPRESSLY EXCLUDED. SLLC SHALL NOT BE LIABLE OR RESPONSIBLE FOR ANY CONSEQUENTIAL, INCIDENTAL, INDIRECT, EXEMPLARY, SPECIAL, OR PUNITIVE DAMAGES, EVEN IF SLLC HAS BEEN ADVISED OF THE POSSIBILITY OF SAME. THE WARRANTY HOLDER IS SOLELY RESPONSIBLE FOR THE SUITABILITY OF THE PRODUCT FOR ANY PARTICULAR APPLICATION.

<b>Product Purchased Region</b>	<b>Product Installed Region</b>	<b>Warranty Holder</b>	<b>Warranty Duration</b>
<b>U.S and Canada</b>	<b>U.S and Canada</b>	<b>End User</b>	<b>Five (5) Years</b>
<b>All Other Conditions</b>		<b>Immediate Purchaser</b>	<b>Earlier of 1 year from installation or 18 months from shipment</b>

## Type P



# Table of Contents

<b>Chapter</b>	<b>Page</b>
Table of Contents .....	V
List of Tables and Figures .....	VI
Summary & Introduction .....	1
Summary .....	1
Important .....	1
Introduction .....	2
Ratings .....	3
Product Description .....	4
Typical Disconnect Switch .....	4
Receiving, Handling & Storage .....	5
Unpacking .....	5
Storage .....	5
Installation & Adjustment Procedures .....	6
Recommended Tools & Values .....	6
Preferred Switch Assembly Method: .....	7
Live Part Installation & Contact Adjustment: .....	11
Mounting Disconnect Switch Onto the Structure: .....	14
Optional Accessories: .....	15
Operating Mechanism .....	17
Final Switch Adjustments (Tuning): .....	18
Changing Disconnect Opening Direction .....	22
Recommended Inspection Maintenance .....	25
Patrolling Inspection (6 Months) .....	25
Routine Inspection and Maintenance (5 year) .....	25
Periodic Inspection and Maintenance (10 year) .....	25
Inspection Checklist .....	26

## List of Tables and Figures

<b>Tables</b>	<b>Page</b>
Table 1: Ratings Table .....	3
Table 2: Recommended Tools and Torque Values .....	6
Table 3: Recommended Installation and Maintenance Table.....	25

<b>Figures</b>	<b>Page</b>
Figure 1: Typical P Switch Pole Assembled & Common Terminology.....	4
Figure 2: Match-Marked Components (72.5kV bearing) .....	8
Figure 3: Match-Marked Components (72.5kV bearing) .....	8
Figure 4: Insulator Stack Alignment (72.5kV Bearing).....	9
Figure 5: Insulator Stack Alignment (245kV Bearing).....	10
Figure 6: Switch - Fully Closed Position.....	11
Figure 7: Blade Contact Adjustment .....	11
Figure 8: Blade Stops (72.5kV Bearing).....	12
Figure 9: Blade Stops (245kV Bearing).....	13
Figure 10: Blade Stops (245kV Bearing) Closed Position .....	13
Figure 11: Insulator Stack Adjustment for Various Mounting Positions (72.5kV Bearing).....	14
Figure 12: Insulator Stack Adjustment for Various Mounting Positions (245kV Bearing).....	14
Figure 13: Sling Attachment .....	15
Figure 14: Blade Lock.....	16
Figure 15: Typical Operating Arrangement .....	17
Figure 16: Type HOGO (High Output Geared Operator) Front View .....	18
Figure 17: Type SEGO (Safety Enhanced Gear Operator) Front View .....	19
Figure 18: Switch – Fully Open Position (Top View) .....	21
Figure 19: Adjustable Arm Assembly .....	21

## Summary & Introduction

### Summary

These instructions do not intend to cover all details or variations in equipment, or provide for every possible contingency to be met in connection with installation, operation or maintenance. Should information be desired or should particular problems arise which are not covered sufficiently for the purchaser's purposes, the matter should be referred to the local Southern States Representative.

The contents of this instruction manual should not become part of or modify any prior or existing agreement, commitment or relationship. The sales contract contains the entire obligations of Southern States. The Warranty contained in the contract between the parties is the sole warranty of Southern States. Any statements contained herein do not create new warranties or modify the existing warranty.

### Important

The information contained herein is general in nature and not intended for specific application purposes. It does not relieve the user of responsibility to use sound practices in application, installation, operation, and maintenance of the equipment purchased. Southern States reserves the right to make changes in the specifications shown herein or to make improvements at any time without notice or obligations. Should a conflict arise between the general information contained in this publication and the contents of drawings or supplementary material, or both, the latter shall take precedence.

## Summary & Introduction

### Introduction

Southern States Type P switch is a three phase, group operated, center side break air disconnect switch. Poles can be mounted in a horizontal “upright”, vertical, or under hung position. The switch can be operated using a manual operator or electrical motor operator (Operating Mechanism).

The installation procedure for all mounting positions and operating schemes is similar and explained herein. A system of pipes, bearing, and adjustable length arms is utilized to open and close the switch from a ground level operator.

The instructions contained within this manual are necessary for the safe installation, maintenance, and operation of the Type P switch. A qualified person, familiar with this of type equipment, should carefully read and follow the instructions.

These instructions are intended to provide a general guideline for the installation, adjustment, and maintenance of the Type P switch. All details, equipment variations, and potential conditions may not be covered in this manual. Contact Southern States, LLC in the event conditions associated with a specific application are not sufficiently addressed.

All photographs and sketches in this manual are for illustration purposes only and may not be to scale. Refer to the Unit Assembly drawing or the Operating Mechanism drawing provided with each disconnect switch for specific details. During installation, it may be necessary to make adjustments other than those described in this manual. Contact your local representative or the factory if questions should arise.

Southern States After Sales and Service Department is available for field installation assistance along with providing parts support for all Southern States products.

Contact After Sales and Service at 770-946-4562, 7:30am-4:00pm EST Monday-Friday.  
After Hours: 770-946-4565

Distinctive signal words are used to indicate the degree of hazard that may be encountered by the user. Identification of the signal words and their definition follow:

**▲ DANGER**

Indicates an imminently hazardous situation, which, if not avoided, will result in death or serious injury.

**▲ CAUTION**

Indicates a potentially hazardous situation, which, if not avoided, may result in minor or moderate injury. It may also be used to alert against unsafe practices.

**▲ WARNING**

Indicates a potentially hazardous situation, which, if not avoided, could result in death or serious injury.

## Summary & Introduction

### Ratings

**Table 1: Ratings Table**

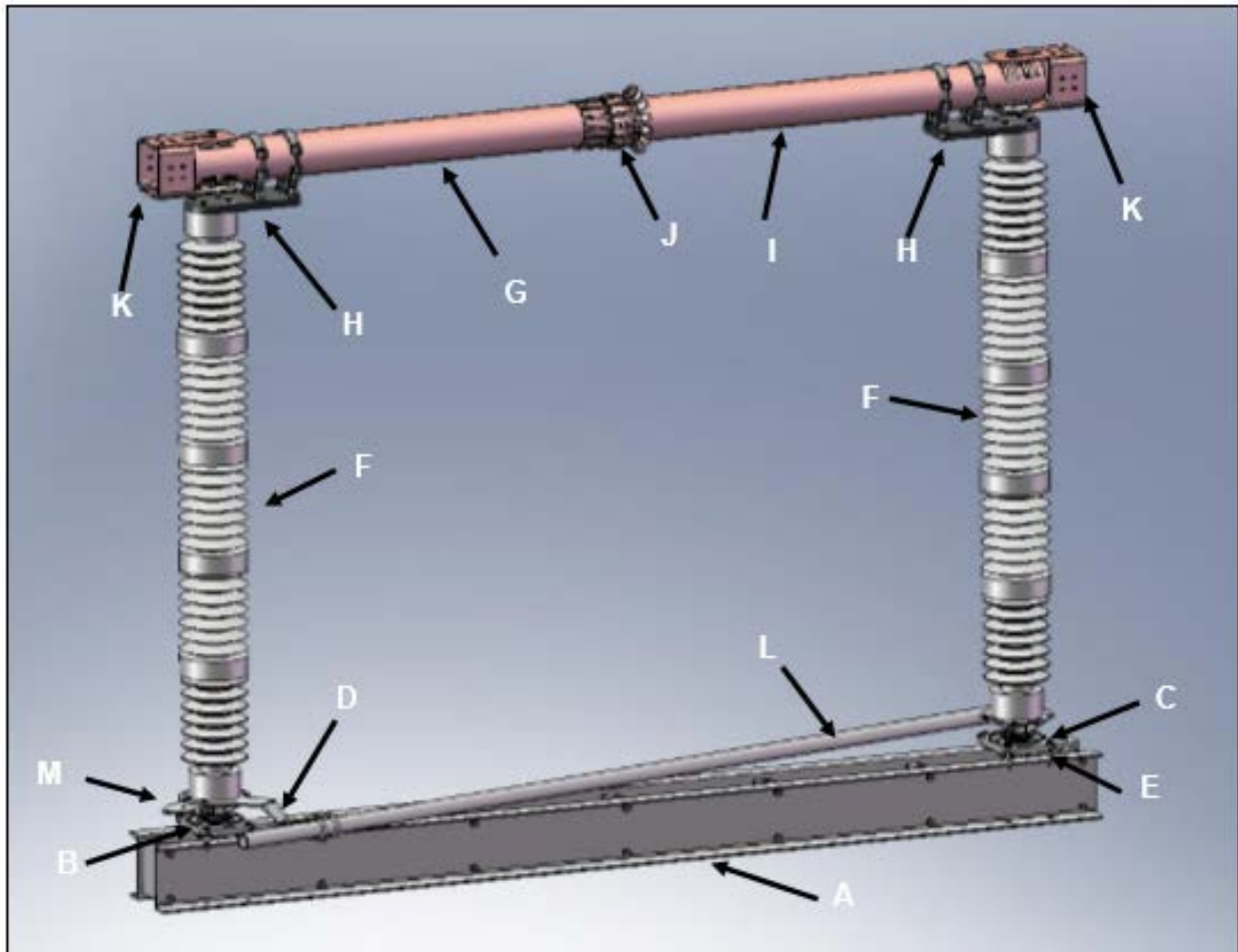
RATINGS						
Maximum Voltage Rating (kV)						
38	48.3	72.5	123	145	170	245
BIL (kV)						
200	250	350	550	650	750	900/1050
ADDITIONAL RATINGS						
Rated Power Frequency				60 Hz		
Continuous Current				1500 A – 2000 A	3000 A – 5000 A	
Short-Time Symmetrical Withstand (3 Sec.)				63 kA RMS Standard	80 kA RMS Standard	
Peak Withstand				164 kA	208 kA	
Ambient Temperature Rating				-40°C to +50°C Standard -50°C Optional		

## Product Description

### Typical Disconnect Switch

In general, installing a disconnect switch consists of the following:

- Mounting the insulators (**F**) to the switch base (**A**)
- Mounting the live parts (**G & I**) to the insulators
- Mounting the switch base (**A**) to the structure
- Installing operating mechanism components
- Final adjustment or tuning



- |                       |                           |                          |
|-----------------------|---------------------------|--------------------------|
| A – Switch Base       | E – Jacking Bolts         | J – Contact Fingers      |
| B – Bearing Stop      | F – Insulator             | K – Terminal Pad         |
| C – Insulator Bearing | G – Female Blade Assembly | L – Operating Rod        |
| D – Inter-Pole Arm    | H – Hinge                 | M – Switch Operating Arm |
|                       | I – Male Blade Assembly   |                          |

**Figure 1: Typical P Switch Pole Assembled & Common Terminology**  
 (Corona Rings are for 245kV and above and are not shown.)

## Receiving, Handling & Storage

### Unpacking

Unpack the equipment and check for damages or material shortages immediately. The bill-of-material from the Unit Assembly (switch) and Operating Mechanism drawings should be used for this purpose. If damage or a shortage is noted, file a claim immediately with the carrier and contact the factory.

### Storage

All components of the Cole Type P center break disconnect switch are suitable for outdoor use. Keep bearings out of standing water. Keep upright and support live parts with base. If a motor operator is furnished, be sure to connect the heater circuit using the provided external wiring, while the unit is in storage. Discard the wiring upon installation.

*Typical crating is intended for storage less than 1 year. If long term storage is required please notify factory at time of order placement so that special crating can be used.*

## Installation & Adjustment Procedures

### Recommended Tools & Values

**Table 2: Recommended Tools and Torque Values**

Recommended Tools		Recommended Torque Values	
Type	Sizes	Bolt/Nut size	Torque (Ft-lb)
Hand Wrenches and/or Sockets	15/16", 3/4", 5/8", 9/16"	1/2"	50 (S. Steel) 40 (All Others)
Drill Bit	1/4"	5/8"	92
		3/4"	127
		1"	286

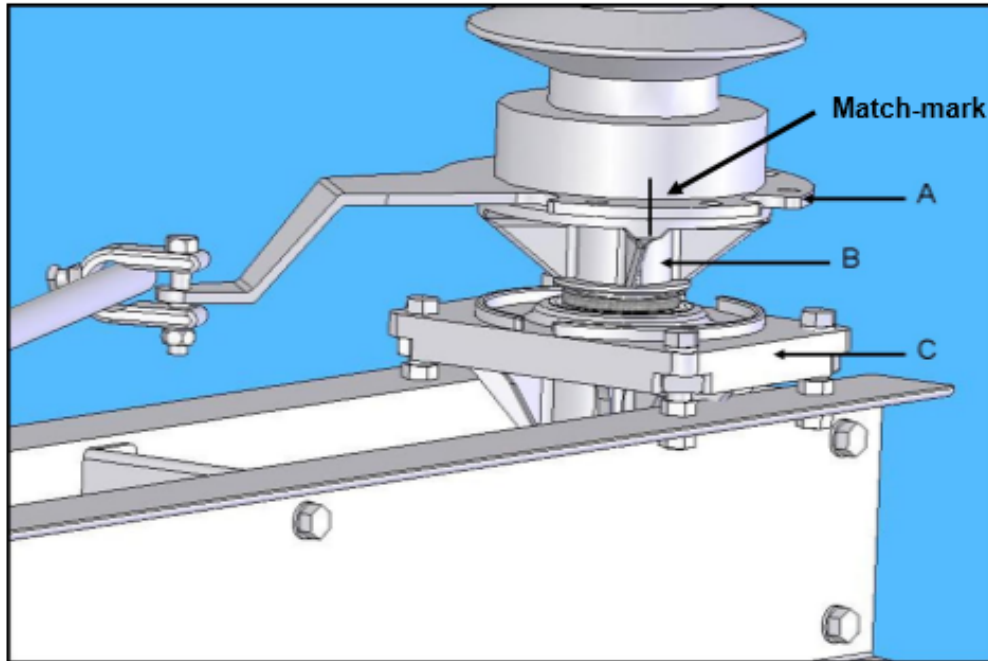
## Installation & Adjustment Procedures

### Preferred Switch Assembly Method:

If Disconnect switch is shipped assembled on insulators Skip this section and continue to [Live Part Installation & Contact Adjustment](#).

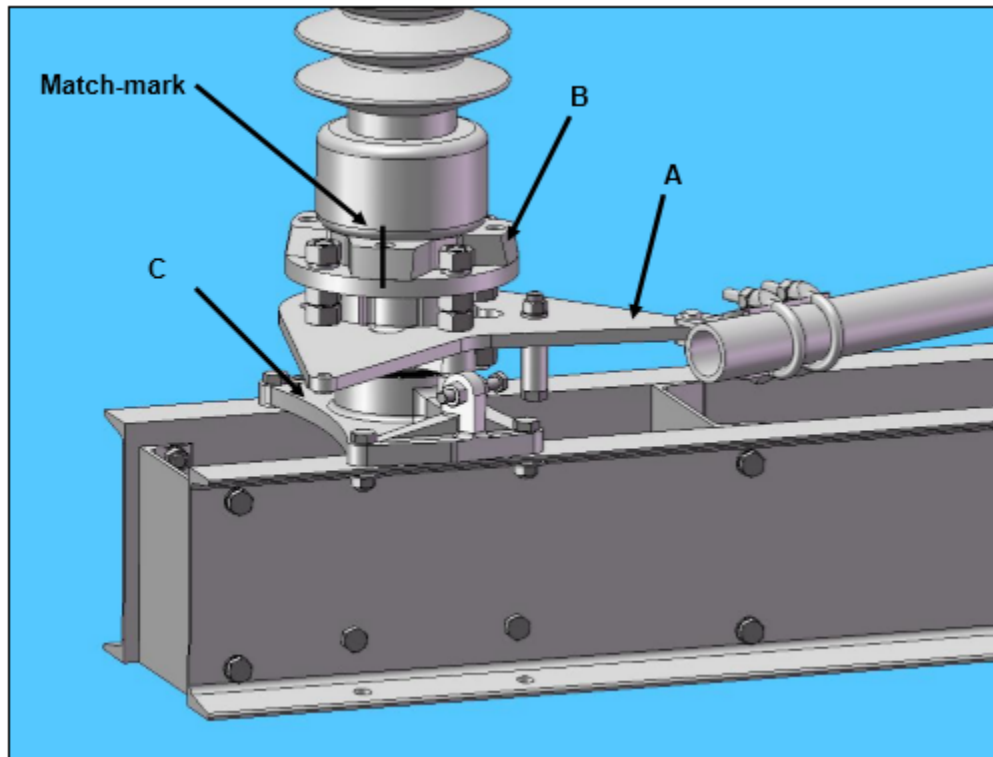
1. Assemble the switch pole on the ground and hoist it to the structure as a complete unit. **CAUTION:** To prevent overturning during assembly, the switch base must be securely attached to a level, stable platform. **CAUTION:** Lift fully assembled pole unit by the base only. **DO NOT lift the pole unit by the live parts.** Refer to **Figure 13**.
2. Before disassembling the live parts from the switch base you must match mark each of the parts indicated to ensure correct re-assembly. Match-mark A to B and B to C as shown in **Figure 2**. **Rotate seismic blade lock assembly 90 degrees to prevent interference during operation.** Failure to complete this step will make final adjustment more difficult.
3. Remove the switch live parts from the shipping spacer (painted red) [if provided], insulator bearings, and inter-pole arms. Make sure to save and reuse hardware if required by the Unit Assembly drawing.
4. While it is typically not necessary to disconnect the operating rod from the inter-pole arm, if it must be disconnected match mark it first. *Failure to complete this step will remove the factory adjustment.*
5. Mount the insulator to the inter-pole arm and then to the bearing. Confirm match marks are aligned and properly torque the bolts (see **Table 2**).
6. Confirm proper insulator alignment, both insulators must be as near to perpendicular as possible to both the long and short axis of the disconnect switch base. **NOTE:** The original insulator stack height must be maintained. When the nuts on the jack bolts are used to adjust insulator tilt, opposite nuts must be turned equally (run one nut up a certain number of turns, turn the opposite nut down the same number of turns). Refer to **Figure 4** and **Figure 5**.

## Installation & Adjustment Procedures



**Figure 2: Match-Marked Components (72.5kV bearing)**

A = Inter-pole Arm    B = Bearing Hub    C = Bearing



**Figure 3: Match-Marked Components (72.5kV bearing)**

A = Inter-pole Arm    B = Bearing Hub    C = Bearing

## Installation & Adjustment Procedures

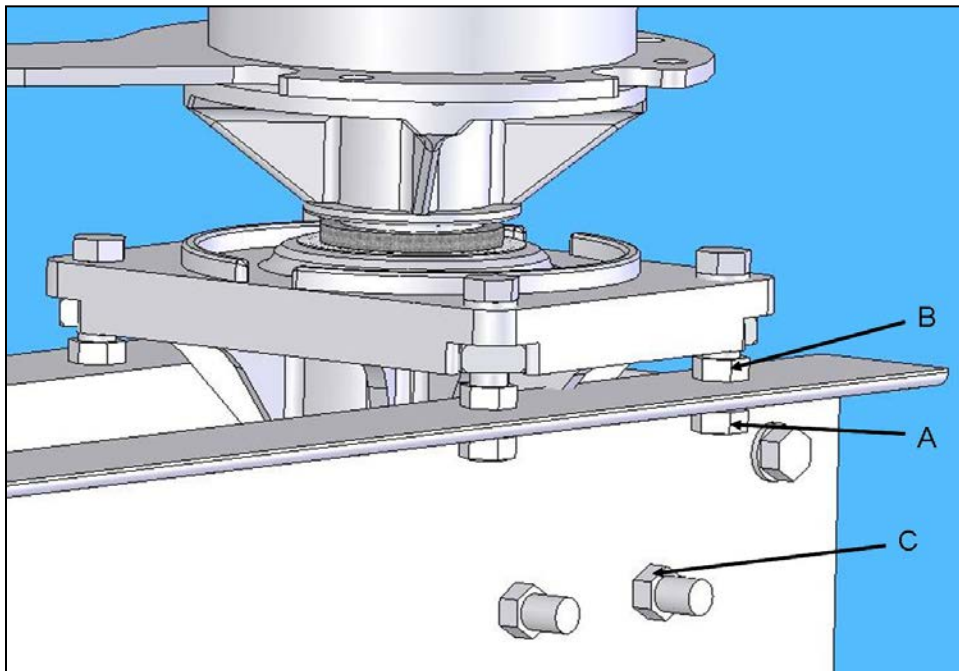
1. Rotate the insulator to the closed position stop on the bearing.
2. Use a plumb bob or other straight line tool (e.g. laser level) to verify that the insulator is level.
3. If the insulator needs adjustment, use the nuts on the jack bolts of the insulator bearing to tilt the insulator in the needed direction. Refer to **Figure 4** and **Figure 5**.

**NOTE:** Vertically mounted **72.5kV** switches may require the following additional steps once mounted due to extra deflection, or sagging:

Refer to Figure 4:

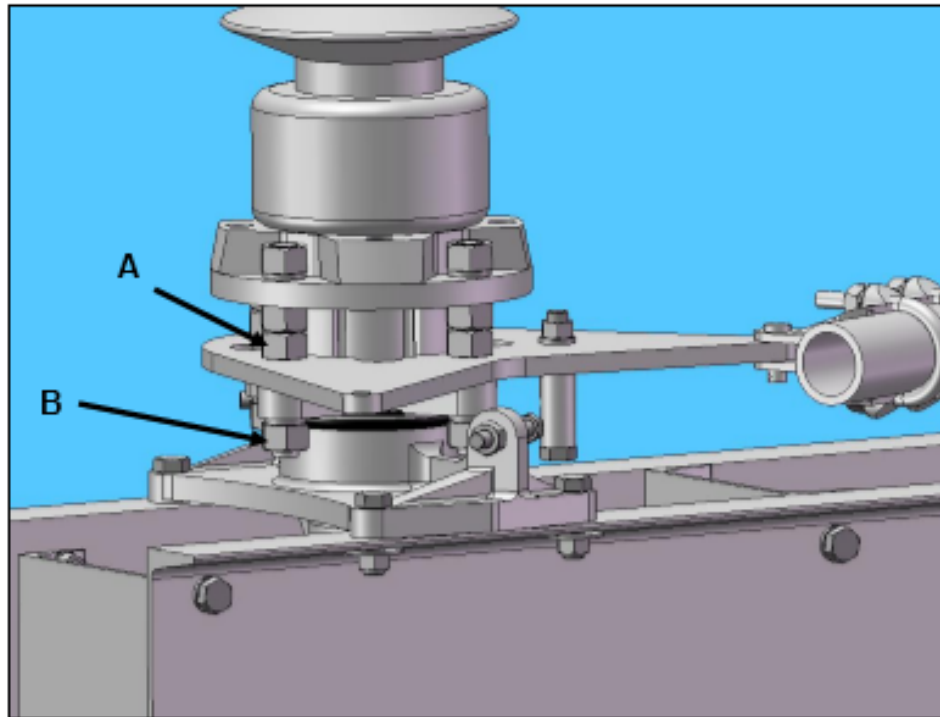
**Caution: Do not turn stud!**

- i. Loosen all four "A" nuts.
- ii. Loosen both "C" nuts if provided.
- iii. Tilt insulator to necessary angle.
- iv. Adjust all four "B" nuts (up or down) until proper alignment is achieved.
- v. Retighten nuts to proper torque.



**Figure 4: Insulator Stack Alignment (72.5kV Bearing)**

Installation & Adjustment Procedures

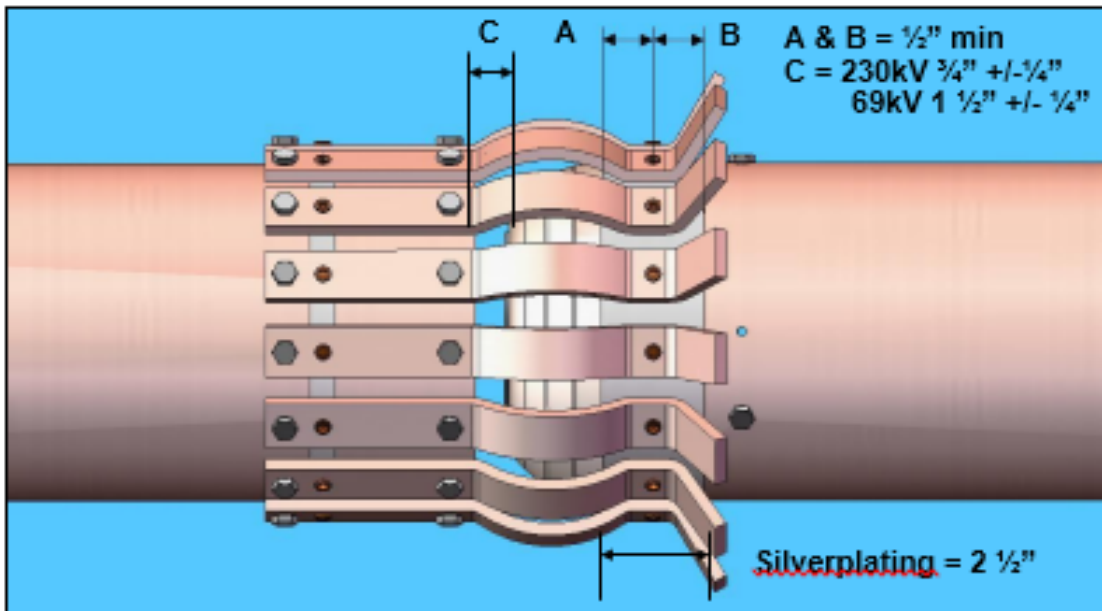


**Figure 5: Insulator Stack Alignment (245kV Bearing)**  
(A = Jacking Bolt, B = Jacking Nut, C = Adjustment Bolt)

## Installation & Adjustment Procedures

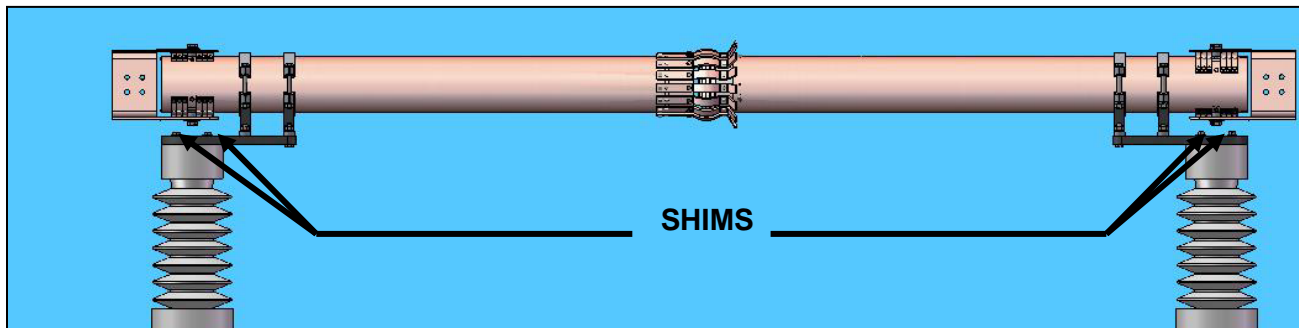
### Live Part Installation & Contact Adjustment:

1. Rotate bearing slightly to open, mount the male and female blade assemblies on top of the insulators using the hardware indicated on the Unit Assembly drawing (see **Table 1**).
  - Confirm that switch is oriented properly, per the unit assembly drawing.
  - Confirm that the match marks are aligned before tightening hardware.
  - If corona rings are provided, refer to the Unit Assembly drawing for installation location
2. With the male and female blade assemblies in the closed position verify, using a level, that both blades are in the same plane and that their centerlines are aligned. A slight variance is acceptable provided that the male contact is approximately perpendicular in the female contacts. Refer to **Figure 6**.



**Figure 6: Switch - Fully Closed Position**

If contact adjustment is necessary, various sizes of stainless steel shims are provided for adjustment. Insert the shims between the insulator end cap and blade hinge until proper alignment is achieved. Torque the bolts to proper value (see **Table 2**). Refer to **Figure 7**



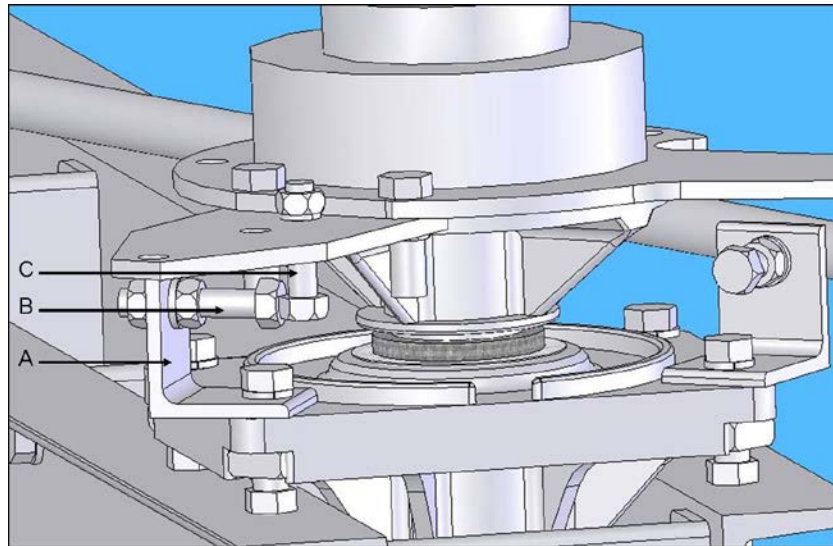
**Figure 7: Blade Contact Adjustment**

## Installation & Adjustment Procedures

- Contact fingers should be centered or as close as possible to the center of the silver area on the male blade. Contact fingers must make contact with the silver area on male blade in closed position as shown in **Figure 6**. A variance of  $\pm \frac{1}{4}$ " between the center of the silver on the male blade and the silver on the contact fingers is permissible as shown in **Figure 6**.

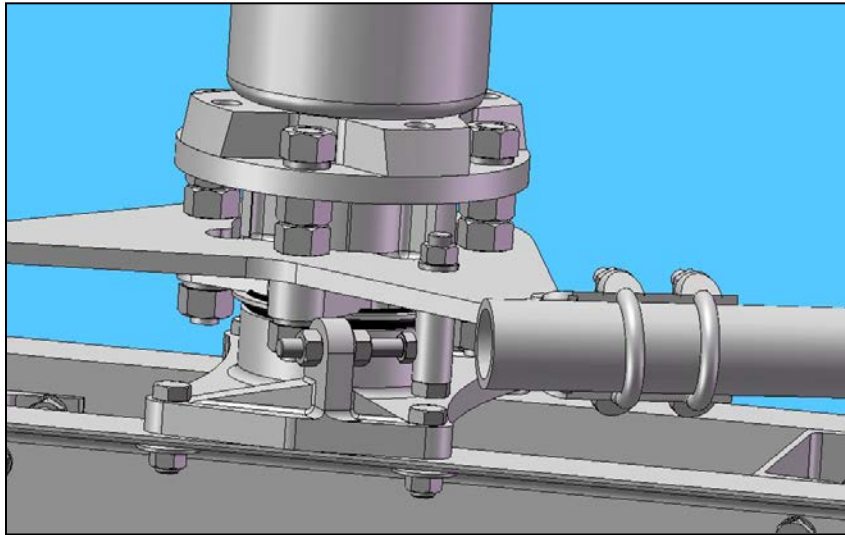
Use only one stop to set up the switch, with the other two stops completely backed off, then adjust the crank arm stop to either touch or rest within  $\frac{1}{4}$ " of the blade stops. If adjustment is necessary, loosen the nuts on the adjusting bolt and adjust the bolt until the distance between the blade stop and the stop is correct. Torque the nuts to proper value.

See **Table 1**. Refer to **Figure 8**, **Figure 9**, **Figure 10**

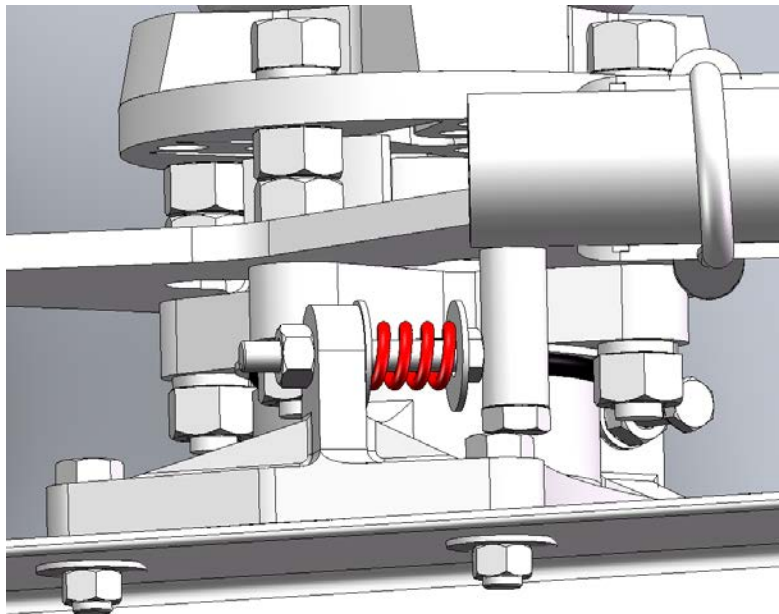


**Figure 8: Blade Stops (72.5kV Bearing)**  
**A= Stop, B=Crank Arm stop, C= Adjusting bolt (72.5kV Bearing)**

Installation & Adjustment Procedures



**Figure 9: Blade Stops (245kV Bearing)**  
Open Position (Seismic Stop Adjustment – Overall Length = 2”)

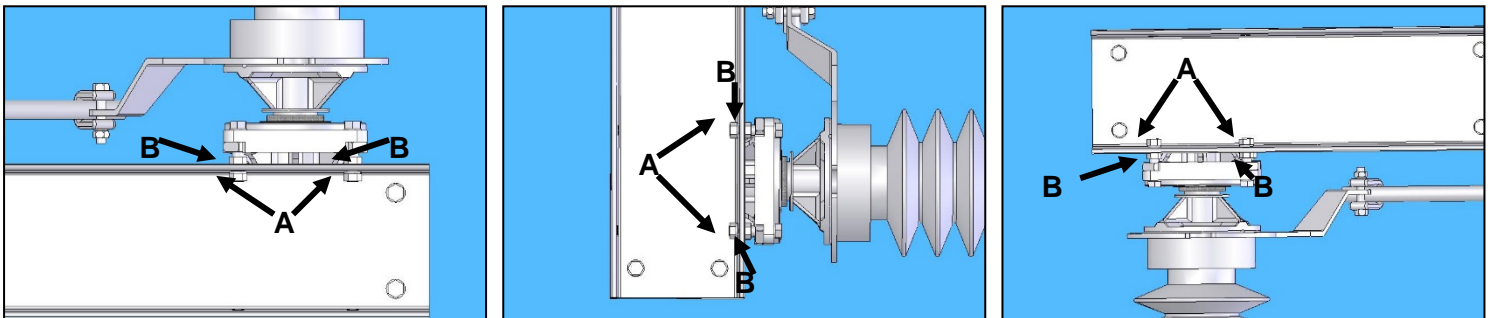


**Figure 10: Blade Stops (245kV Bearing) Closed Position**  
*Overall Length of Assembly = 2” +/- 1/2”*

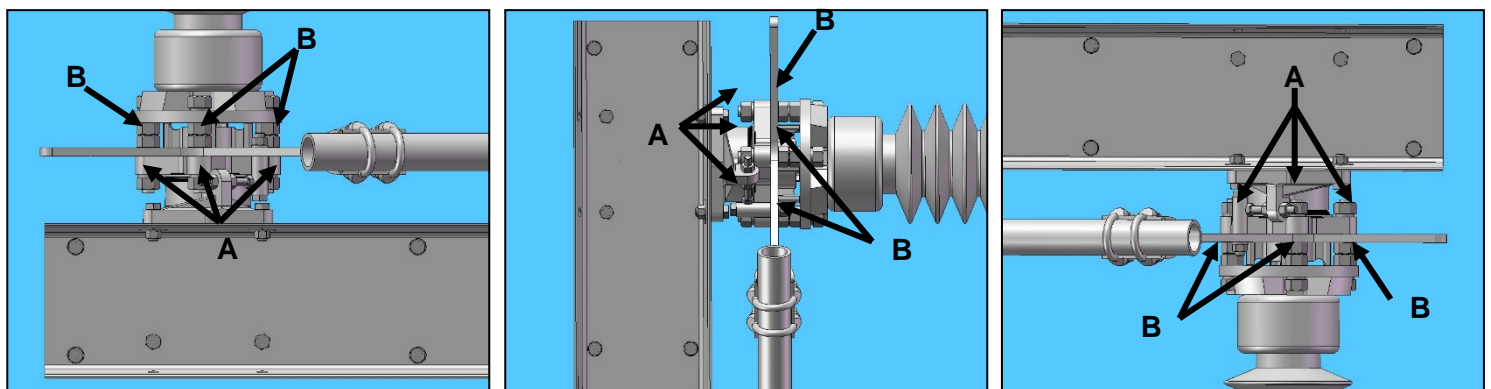
## Installation & Adjustment Procedures

### Mounting Disconnect Switch Onto the Structure:

1. Recheck the Operating Mechanism drawing to confirm the correct position of the disconnect switch pole on the structure.
2. With the switch closed, secure the male and female blade assemblies using rope or other type of strap, to avoid movement during lifting.
3. Secure the switch arm to the bearing stop prior to lifting.
4. Lift the assembled switch by the switch base only. Refer to **Figure 13**.
5. Mount the disconnect switch to the structure using the hardware indicated by the Operating Mechanism drawing (see **Table 1**).
6. **If possible** mount the conductors to both ends of the switch pole before adjusting switches. Conductor loads can alter fine switch adjustments, so final adjustments should not be performed prior to connecting the conductors.
7. Verify that the insulators are still properly aligned.
  - Refer to **Figure 5, Figure 11** and **Figure 12**. Adjust both “A” nuts and “B” nuts equally to prevent misalignment.
  - After adjustment, torque the nuts properly (see **Table 2**).



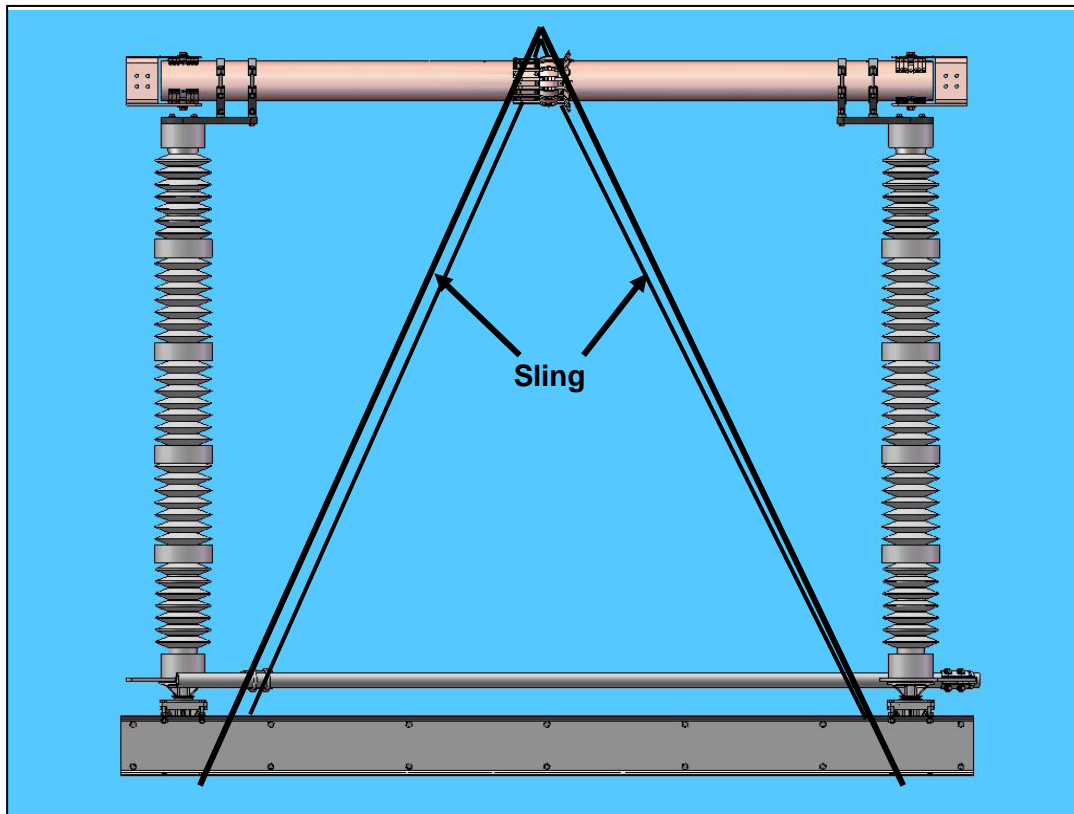
**Figure 11: Insulator Stack Adjustment for Various Mounting Positions (72.5kV Bearing)**



**Figure 12: Insulator Stack Adjustment for Various Mounting Positions (245kV Bearing)**

(A = Jacking Bolt, B = Jacking Nut, C – Adjustment Bolt)

## Installation & Adjustment Procedures



**Figure 13: Sling Attachment**

### Optional Accessories:

1. Blade Lock (if equipped):
  - In the closed position the seismic blade lock is used to prevent the blades from parting during a seismic event. Please refer to **Figure 14** adjustment measurements.
    - If adjustment is necessary loosen the four (4) bolts on the lock holder and move back and forth to the desired position. Tighten bolts to recommended torque settings **Table 1**. (50 ft. lbs.)
2. Arcing Horns (if equipped):
  - Refer to the Unit Assembly drawing for necessary hardware and installation location.
  - Arcing horns should rub together with sufficient pressure to maintain contact, but not to cause binding.
  - Arcing horns should be touching before switch contacts separate from each other. If necessary the arcing horn can be bent to achieve proper contact.



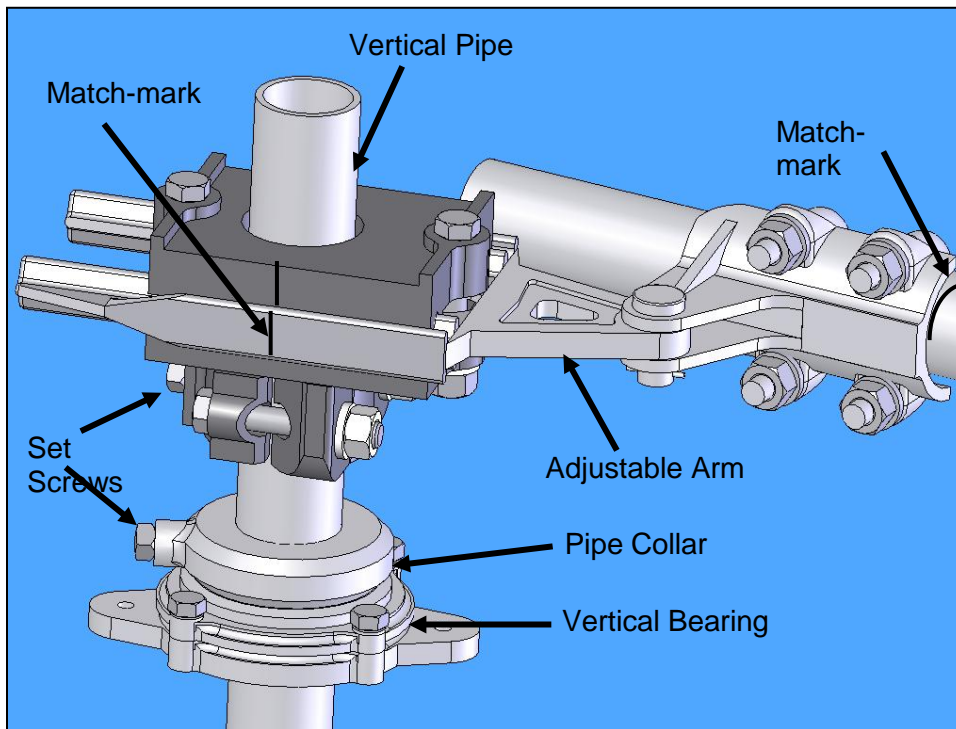
## Installation & Adjustment Procedures

### Operating Mechanism

(See Operating mechanism drawings provided for details):

1. Lay out all op-mech parts and check them against the Operating Mechanism drawing bill-of-material.
2. To ensure that the bearing stops do not interfere with switch adjustments, loosen each open/close bearing stop and slide them out of the way.

Refer to the Operating Mechanism drawing and install all mounting brackets, bearings, bushings, pipe clevises, switch operating device, adjustable arm, reach rod, and other necessary components. Refer to **Figure 15**.



**Figure 15: Typical Operating Arrangement**

3. **Caution:** The pipe collar (above the vertical bearing) must support the entire weight of the vertical operating pipe. To prevent unnecessary component damage, **Do not allow the pipe to rest on the switch operating device.** Refer to **Figure 16**.
4. While installing the pipes and clevises that have piercing bolts/set screws, do not pierce the pipe until instructed. Tighten the piercing bolts such that they grip the pipe until all adjustments are made.
5. After mounting all op-mech components, match-mark all clevis connections, the adjustable arm, and the switch operating device's coupling, so that you can tell if slippage occurs during trial operations.

## Installation & Adjustment Procedures

### Final Switch Adjustments (Tuning):

1. The operating mechanism is intended to fully open and fully close the disconnect switch by rotating the vertical operating pipe approximately 180° using an operator (manual or electrical). The interphase pipe controls the individual operation of each switch pole, using a push/pull control. The reach rod translates the motion of the vertical operating pipe to the interphase linkage. The adjustable arm controls the total amount of switch operation available.

For easiest adjustment start with the reach rod connected to the drive phase and the interphase pipe disconnected from the other two phases. Once the drive phase is properly adjusted, connect the interphase pipe and continue tuning the other two phases, one at a time.

2. Switch Operating Devices:

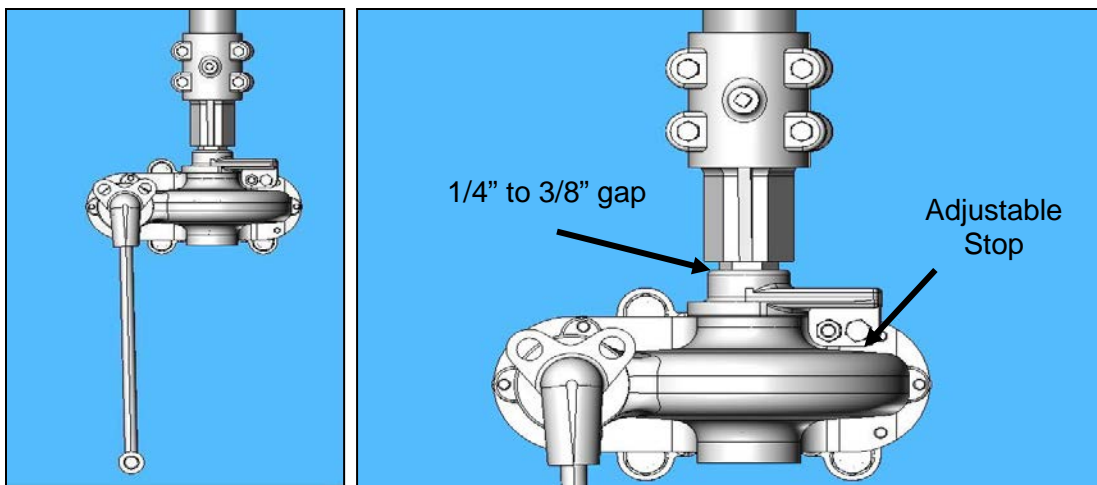
- 2.1 Worm gear operator (HOGO – High Output Geared Operator) (Optional)

- 2.1.1. The operator handle is factory set to rotate clockwise to open the switch.

- 2.1.2. The weight of the vertical operating pipe should be supported by pipe collar (**Figure 15**) by maintaining the 1/4 - 3/8" gap (**Figure 16**).

- 2.1.3. When the switch is properly adjusted the operator handle should hang freely in both the open and closed positions to permit the use of a customer supplied padlock. Refer to **Figure 16**.

- 2.1.4. **Caution:** Be aware that there is an adjustable stop on the operator. **Do not** over operate as damage will occur to the operator.



**Figure 16: Type HOGO (High Output Geared Operator) Front View**

- 2.2 Swing handle operator

- 2.2.1 When the switch is properly adjusted the handle should hang vertically and free in both the open and closed positions to permit the use of a customer supplied padlock.

## Installation & Adjustment Procedures

### 3 Worm gear operator (SEGO – Safety Enhanced Gear Operator) (Optional)

- 3.1 The weight of the vertical operating pipe should be supported by pipe collar by maintaining the 1/4"-3/8" gap.
- 3.2 When the switch is properly adjusted the operator handle should hang freely in both the open and closed positions to permit the use of the customer supplied padlock.

#### CAUTION

Be aware that there is an adjustable stop on the operator. **Do not** over operate as damage will occur to the operator.

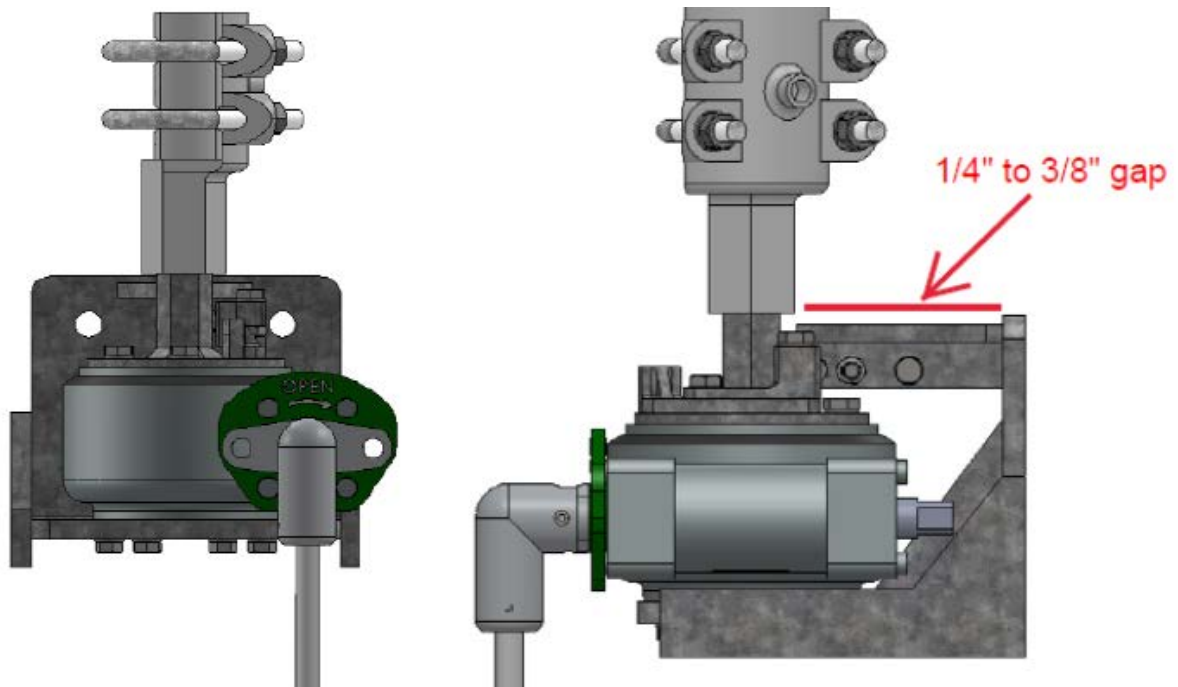


Figure 17: Type SEGO (Safety Enhanced Gear Operator)

### 3.3 Electrical motor operator

- 3.3.1 Please refer to motor operator instruction manual for proper installation and setup.
- 3.3.2 Use manual operation while completing switch setup.
- 3.3.3 **Do not** electrically operate until all switch adjustments are complete. **ALWAYS** operate the motor operator decoupled first to ensure proper setup.

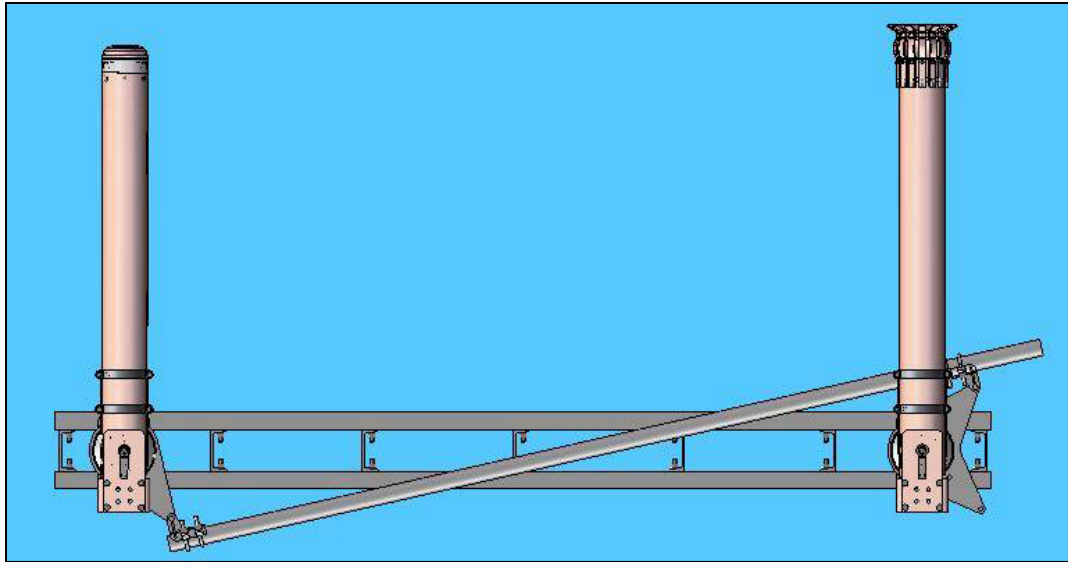
### 4 Preliminary Switch Settings:

- 4.1 Start with the disconnect switch and operating mechanism in the closed position. Refer to **Figure 6**.

## Installation & Adjustment Procedures

- 4.1.1 The switch is in the fully closed position when the centerline of the male blade assembly is aligned with the centerline of the Female Blade Assembly.
  - 4.2 Set the adjustable arm to the preliminary setting on the Operating Mechanism drawing, adjustment may be necessary to achieve proper operation.
  - 4.3 Be sure that all stops have been loosened to prevent binding during test operations.
- 5 Final Adjustment:
  - 5.1 Before making any adjustments always check that none of the pinned joints have slipped. If slippage occurs, correct it and repeat the operation to verify that adjustment is really needed.
  - 5.2 Open the disconnect switch with the operator.
  - 5.3 The switch is in the fully open position when both blades are approximately 90° to the switch base. **Figure 18: Switch – Fully Open Position (Top View)**
  - 5.4 If the switch **does not** fully open before the operator reaches the fully open position, the adjustable arm radius is too short. Close the switch, match-mark the adjustable arm and the pipe clevis, and loosen the bolts on the adjustable arm and pipe clevis. Lengthen the adjustable radius arm approximately ¼". Allow the pipe clevis to reposition itself the same ¼". Refer to **Figure 19**.
    - 5.4.1 Test operate and readjust as necessary.
  - 5.5 If the switch **is** fully open before the operator reaches the fully open position, the adjustable arm radius is too long. Close the switch, match-mark the adjustable arm and the pipe clevis, and loosen the bolts on the adjustable arm and pipe clevis. Shorten the adjustable radius arm approximately ¼". Allow the pipe clevis to reposition itself the same ¼". Refer to **Figure 19**.
    - 5.5.1 Test operate and readjust as necessary.
  - 5.6 If the switch has too much toggle in either open or closed position, loosen the pipe clevis and adjust to allow for an even toggle amount in both positions.
  - 5.7 All poles of the fully adjusted disconnect switch should operate together, although a slight variance between poles is acceptable. The primary objective is for all poles to fully open and fully close. Minor adjustments of the inter-phase pipe clevises may be necessary for pole coordination.

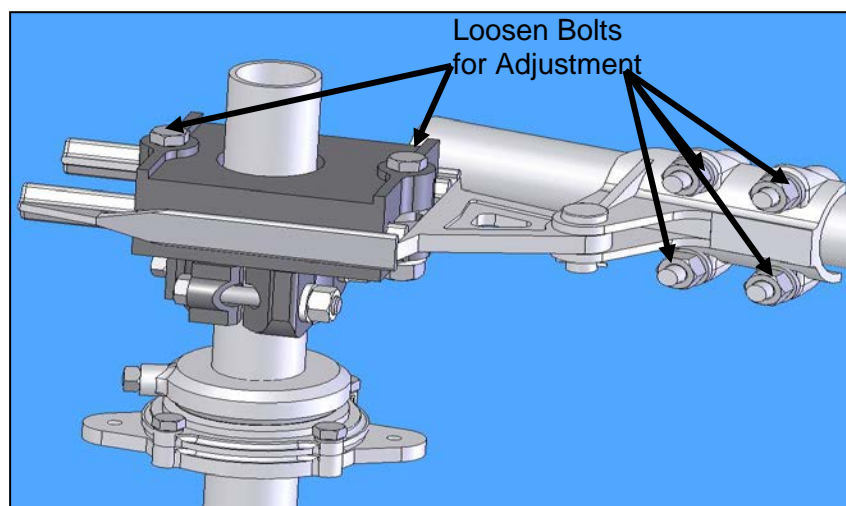
## Installation & Adjustment Procedures



**Figure 18: Switch – Fully Open Position (Top View)**

### 5.8 Setting Toggle:

- 5.8.1 Toggle is obtained when the switch is in the either fully open or fully closed position and the connection point between the adjustable arm and pipe clevis has gone past the centerline of the vertical operating pipe. The operating linkage will snap past this point.
- 5.8.2 If possible the switch should go into toggle in both the open and closed positions. This is not always possible, it is most important that the switch goes into toggle in the closed position to help prevent the disconnect switch from to opening during a fault condition.



**Figure 19: Adjustable Arm Assembly**

## Installation & Adjustment Procedures

### 5.9 Final Check:

- 5.9.1 Once all final adjustments are complete, be sure that all nuts are tightened to their specified torque (Refer to **Table 2**).
- 5.9.2 Apply a minimal amount of grease to the point of each piercing bolt and then tighten the bolt until it pierces the pipe wall. For heavy walled pipe, (schedule 80 or above, 3" or above) pre-drill the piercing bolt holes with a piercing bolt drill guide (provided) and a ¼" drill bit.
- 5.9.3 Position bearing stops to lightly touch, in both the open and closed positions.

## Changing Disconnect Opening Direction

The following are instructions for making field modifications to the opening direction of the disconnect switch if it is determined that it is necessary. If parts or assistance are required please contact your Local Representative or Southern States Service Division, contact information provide on the back page.

If disassembly is required by these instructions *IT SHOULD BE PERFORMED ON THE GROUND*. If this is not possible, proper safety and handling techniques must be used by installation crew to prevent damage to the components or injury to personnel.

1. Horizontally mounted disconnect switches without ground switch
  - 1.1. The simplest way to change disconnect opening direction is to rotate the entire **disconnect switch and** operating mechanism 180 degrees. For visual reference to see what is affected simply rotate the operating mechanism drawing in your hand. You will notice that operating linkage will rotate to the opposite end of the disconnect switch and that the operator will rotate to the opposite structure leg (diagonally from its original location).
  - 1.2. Sling each switch phase and rotate the entire assembly on the structure 180 degrees. Refer to **Figure 13**.
  - 1.3. The switch operator will also need to be relocated. There are 2 options:
    - 1.3.1. Move the operator to the opposite leg, diagonally from its original location. This is the best option as it allows for the original setup to be maintained.
    - 1.3.2. Maintain the operator on the same side of the structure. Assemble the components using the alternate position arrangement shown on the operating mechanism drawing. NOTE on 4 Column structures the operator will be on the same side of the structure, but it **MUST** move to the opposite end of the structure to obtain proper operation.
2. All other disconnect mountings without ground switch – PARTIAL DISASSEMBLY WILL BE REQUIRED
  - 2.1. Disconnect adjustment
    - 2.1.1. With the disconnect phase on the ground, open the switch by hand and secure the linkage in this position.
    - 2.1.2. Unbolt the female blade from the insulator. Place the blade in the closed position and reattach to the insulator. DO NOT move the switch linkage.

## Installation & Adjustment Procedures

- 2.1.3. Unbolt the male blade from the insulator. Place the blade in the closed position and reattach to the insulator. It will likely be necessary to allow the linkage to move toward the “new” OPEN direction to be able to reassemble.
  - 2.1.4. Minor adjustments maybe required to the operating rod (Refer to Error! Reference source not found.) to achieve proper open close operation as described in Section 2 above.
- 2.2. Operator and Operating linkage adjustment
- 2.2.1. Swing handle or Worm gear operator
    - 2.2.1.1. **NOTE: Due to space constraints you may not be able to move the adjustable arm to the opposite side of the pipe (structure side). In these cases it is impossible to achieve CLOCKWISE handle rotation to OPEN using a swing handle. The worm gear operator will have to be changed to achieve proper rotation. Please contact representative.**
3. Leave the operator in the starting position as originally shown on the operating mechanism drawing.
  4. To achieve CLOCKWISE handle rotation to OPEN you must attach the adjustable arm 180 degrees from its original setup. The pipe clevis will also need to be rotated to the opposite side of the adjustable arm (side closest to the structure) but with the radius of the clevis still pointing toward the disconnect switch. The adjustable arm will now rotate toward the structure instead of away from it.
  5. Attach all other items as shown in the operating mechanism drawing.
  6. If the mechanism was originally setup for PUSH to OPEN it has now been changed to PULL to OPEN and vice versa.
  5. Horizontally mounted disconnect switches with EVG-1 ground switch – **PARTIAL DISASSEMBLY WILL BE REQUIRED.** Please contact Local Representative or Southern States Service Division immediately. **New brackets for the ground switch and a new main switch operator will be required to make this change.**
- 5.1 Disconnect adjustment
- 5.1.1 With the disconnect phase on the ground, remove the ground switch and mounting bracket as a complete assembly.
  - 5.1.2 If the insulators have not been installed, unbolt the live parts from the switch bearings and flip the paddle arms on each bearing along the long axis of the switch base. Reinstall all items as described in section 1.
  - 5.1.3 If the insulators have been installed, unbolt the male and female blades from the insulator. Unbolt the insulators from the switch bearings and flip the paddle arms on each bearing along the long axis of the switch base. Reinstall all items as described in section 1.
  - 5.1.4 Minor adjustments maybe required to the operating rod (Refer to Error! Reference source not found.) to achieve proper open close operation as described in Section 2 above.
- 5.2 Ground Switch Adjustment
- 5.2.1 Rotate the ground switch jaw 180 degrees and reattach to disconnect blade.

---

## Installation & Adjustment Procedures

5.2.2 Install new support bracket to the switch base. The ground switch must be installed on the OPEN side of the disconnect. Adjust the jacking bolts on the bracket until ground switch fits properly into its jaw.

### 5.3 Operator and Operating linkage adjustment

5.3.1 Both operators must move to the opposite leg(s) of the structure directly across from their current position

#### 5.3.2 Operator

- Setup operating linkages as shown in revised operating mechanism drawings that will be provided.
- Please note that a new operator will be needed for the main switch. The ground switch operator is the same.

## Recommended Inspection Maintenance

### Recommended Inspection Maintenance

The Cole Type P Switch has been designed to operate with low maintenance. Periodic inspection is important for satisfactory operation. Frequency of inspection and maintenance depends on the installation site, weather and atmospheric conditions, experience of operating personnel and special operation requirements.

**Table 3: Recommended Installation and Maintenance Table**

		Installation Tests	Patrolling Inspection 6 month	Routine 5 Year *	Periodic 10 Year *
<b>Insulators</b>	Contamination	X	X	X	X
	Damage	X	X	X	X
<b>Cabinet (if motor operator supplied)</b>	Any loose parts on the floor of the cabinet?	X	X	X	X
	Wiring Secure	X	X	X	X
	Links Secure	X	X	X	X
	Inspect Mechanism for loose parts	X	X	X	X
	Heaters Energized	X	X	X	X
	Door Seal	X	X	X	X
	<b>Mechanical</b>	Operational Tests	X		X
<b>Electrical</b>	Contact Resistance	X		X	X
<b>Liveparts Inspection</b>	Inspect Contacts	X		X	X
	Inspect Arcing Horns	X		X	X

\*Note: Harsh environments with excessive airborne contaminants, such as, salt spray and industrial pollutants will require inspection/maintenance every two (2) years.

For specific instructions please refer to the SCE disconnect maintenance guidelines.

### Patrolling Inspection (6 Months)

The patrolling inspection is a largely visual inspection on an energized unit in service. The frequency of the inspection is determined by the local conditions and policies of the owner of the equipment. Refer to **Table 3** for recommended inspection items.

### Routine Inspection and Maintenance (5 year)

Routine inspection is performed on a de-energized unit. The frequency of the inspection is determined by the local conditions and policies of the owner of the equipment. Refer to **Table 3** for recommended inspection items.

### Periodic Inspection and Maintenance (10 year)

Periodic inspection is performed on a de-energized unit. The frequency of the inspection is determined by the local conditions and policies of the owner of the equipment. Refer to **Table 3** for recommended inspection items.

## Recommended Inspection Maintenance

### Inspection Checklist

<b>245 KV COLE P TYPE DISCONNECTS (Rev 3) (6-2013)</b>			
<b>SUBSTATION NAME</b>		<b>POSITION</b>	
<b>SITE REP:</b>		<b>DATE:</b>	
<b>ACCEPTED BY QC:</b>		<b>DATE:</b>	
<b>INSTALLER:</b>			
<b>SAP NUMBER:</b>		<b>KV RATING:</b>	
<b>S.S. #</b>		<b>AMP RATING:</b>	
<b>INSTALLATION PER SOUTHERN STATES MANUAL</b>			
	<b>Installer</b>	<b>Site Rep</b>	<b>OC</b>
Check for damage or material shortages (Page 5)			
All Nuts, Bolts and other hardware are Tight and Torque marked			
Pipe Collar supporting Vertical Drive Pipe (Refer to 2.0.2 Page 17)			
All Cotter Keys are Bent			
Blades Centered in The Clip ( Figure 6 Page 10)			
Blades Closed Gap 3/4" to 1/4" (Figure 6 Page 10)			
Blades Closed & Aligned ( Refer to 2 on Page 10)			
Blades Straight In Open Position (Figure 17 Page 18)			
Verify Contact Wipe - Timing (within 3/4")			
Open rotation Stops Engaged On Insulator Stack (Figure 9 Page 11)			
Closed rotation Stops factory set no adjustment required (Figure 10 Page 12)			
Verify Min. Gap On HOGO Handle 1/4 to 3/8 gap (Figure 16 Page 17)			
Blade Lock adjusted per (Figure 14 Page 15)			
Handle is 40 inches from grade (+/- ) 3 inches			
Handle is Hanging Free (Refer to 2.0.3 on Page 17)			
Handle - Clockwise to Open			
Handle and Structure Ground Attached			
Handle Stop Touching in The Closed Position			
Handle Stop Touching In The Open Position			
Handle operating pressure less than 35 pounds of force			
Name Plate attached by handle			
Signs- Open & Closed Properly Installed			
Toggle in Closed Position (Refer to 4.6 on Page 18)			
Toggle in Open Position (Refer to 4.6 on Page 18)			
<b>HOLD Point contact QC 48 Hours notice</b>			
Piercing Bolts Set After Buy-off			





## Local Representative

---



Matt Daniels

Cell (714) 323-4697  
Office (949) 852-1006  
Fax (949) 852-1447  
[matt@mkireps.com](mailto:matt@mkireps.com)



# Southern States

**The Quality Name in High Voltage Switching**

30 Georgia Avenue  
Hampton, Georgia 30228  
Phone: 770-946-4562  
Fax: 770-946-8106  
E-mail: [support@southernstatesllc.com](mailto:support@southernstatesllc.com)  
<http://www.southernstatesllc.com>

©2017 Southern States, LLC  
IB-136-EC-1 245-R20 SCE 052617 Printed U.S.A.