



## **TYPE CVB-2**

Vertical Break

Disconnect Switch

15.5 – 245 kV, 2000A

**INSTALLATION &**

**INSTRUCTION**

**MANUAL**

---

The Quality Name in High Voltage Switching

## Safety Information

### DANGER

IMPROPER HANDLING, INSTALLATION, OPERATION OR MAINTENANCE OF THIS EQUIPMENT MAY CAUSE IMMEDIATE HAZARDS WHICH WILL LIKELY RESULT IN SERIOUS PERSONNEL INJURY OR DEATH.

### WARNING

The equipment covered by this publication must be handled, installed, operated and maintained by qualified persons who have direct knowledge and experience dealing with the hazards involved and are thoroughly trained in the handling, installation, operation and maintenance of high voltage transmission and distribution equipment. These instructions are meant for only such **Qualified Persons**. They are not intended to be a substitute for adequate training and experience in safety procedures for this type of equipment.

A **Qualified Person** is one who is trained in and has skills necessary:

- to read and comprehend this instruction book – understanding that these instructions are general in nature
- to accept personal responsibility to prepare and maintain an intrinsically safe work environment and maintain control of the work site to safeguard all persons present
- to develop and implement a proper rigging, lifting, and installation plan along with all safety precautions required to insure safe and proper lifting and installation of the equipment.
- to distinguish between energized and non energized parts
- to determine proper approach distances to energized parts
- to properly work with and around energized or de-energized equipment that may be pressurized with gas
- for proper use of personal protective equipment, insulating and shielding materials, insulated tools for working near energized and /or pressurized electrical equipment
- to recognize and take necessary precautions for the unique and dynamic conditions of site and specialized equipment to maintain a safe work environment during handling, installation, operation, and maintenance of high voltage switching equipment

The instructions in this manual are general guidelines for this type of equipment and not specific to the equipment supplied. Portions of it may not be applicable or may not have complete instructions for your specific equipment.

If you do not understand any part of these instructions or need assistance, contact Southern States Service Division at 770-946-4562 during normal business hours (EST) or 770-946-4565 after normal business hours.

The Quality Name in High Voltage Switching

## LIMITED WARRANTY

Southern States, LLC (“SLLC”) warrants only to the Warranty Holder (hereinafter defined as the “End User” or the “Immediate Purchaser”, as applicable, pursuant to the terms and conditions of this Limited Warranty as set forth below), that the Product identified below will, upon shipment, be free of defects in workmanship and material for the applicable Warranty Period. The “Warranty Period” is that period of time during which this Limited Warranty is effective, and such period begins on the invoice date issued by SLLC for the Product, and continues until the earlier to occur of (1) the expiration of the Warranty Duration period, or (2) the Number of Operations, both as specified in the table below. If the Product is both purchased and installed within the United States or Canada, this Limited Warranty is granted to each end user of the Product who acquired the Product for its own use during the Warranty Period (“End User”). In all other situations, this Limited Warranty is granted only to the first purchaser of the Product (“Immediate Purchaser”) from SLLC. No primary or remote purchaser or owner of the Product who is not a Warranty Holder may claim any benefit under this Limited Warranty, or any remedial promise included in this Limited Warranty. SLLC shall, upon prompt written notice from the Warranty Holder, correct a nonconforming Product by repair or replacement at the sole discretion of SLLC of the nonconforming Product or any part or component of a nonconforming Product necessary in SLLC’s discretion to make such Product conforming. Any transportation charges, labor for removing, reinstalling the Product or part, and/or costs related to providing access to the Product shall be the responsibility of the Warranty Holder. Correction in this manner will constitute the Warranty Holder’s exclusive remedy and fulfillment of all SLLC’s liabilities and responsibilities hereunder. SLLC’s duty to perform under this limited warranty may be delayed, at SLLC’s sole option, until SLLC has been paid in full for all products purchased by the Warranty Holder. No such delay will extend the Warranty Period. If SLLC does not make such repair or replacement, SLLC’s liability for damages on account of any claimed nonconformity will in no event exceed the purchase price of the Product in question. This Limited Warranty does not apply to any Product that has been disassembled, repaired, or altered by anyone other than SLLC. This Limited Warranty will not apply to any Product that has been subjected to improper or abnormal use of the Product. SLLC has no responsibility to repair or replace any Product or component thereof manufactured by another party, but SLLC will assign, to the extent assignable, to the Warranty Holder any manufacturers’ warranty that applies to products and components not manufactured by SLLC.

THIS LIMITED WARRANTY IS EXCLUSIVE AND IN LIEU OF ALL OTHER WARRANTIES. THERE ARE NO OTHER EXPRESS, IMPLIED, OR STATUTORY WARRANTIES. ALL IMPLIED WARRANTIES WHICH MAY ARISE BY IMPLICATION OF LAW, OR APPLICATION OF COURSE OF DEALING OR USAGE OF TRADE, INCLUDING, BUT NOT LIMITED TO, IMPLIED WARRANTIES OF MERCHANTABILITY OR FITNESS FOR A PARTICULAR PURPOSE, NONINFRINGEMENT OR OTHERWISE ARE EXPRESSLY EXCLUDED. SLLC SHALL NOT BE LIABLE OR RESPONSIBLE FOR ANY CONSEQUENTIAL, INCIDENTAL, INDIRECT, EXEMPLARY, SPECIAL, OR PUNITIVE DAMAGES, EVEN IF SLLC HAS BEEN ADVISED OF THE POSSIBILITY OF SAME. THE WARRANTY HOLDER IS SOLELY RESPONSIBLE FOR THE SUITABILITY OF THE PRODUCT FOR ANY PARTICULAR APPLICATION.

<b>Product Purchased Region</b>	<b>Product Installed Region</b>	<b>Warranty Holder</b>	<b>Warranty Duration</b>
<b>U.S and Canada</b>	<b>U.S and Canada</b>	<b>End User</b>	<b>Five (5) Years</b>
<b>All Other Conditions</b>		<b>Immediate Purchaser</b>	<b>Earlier of 1 year from installation or 18 months from shipment</b>

## Type CVB-2

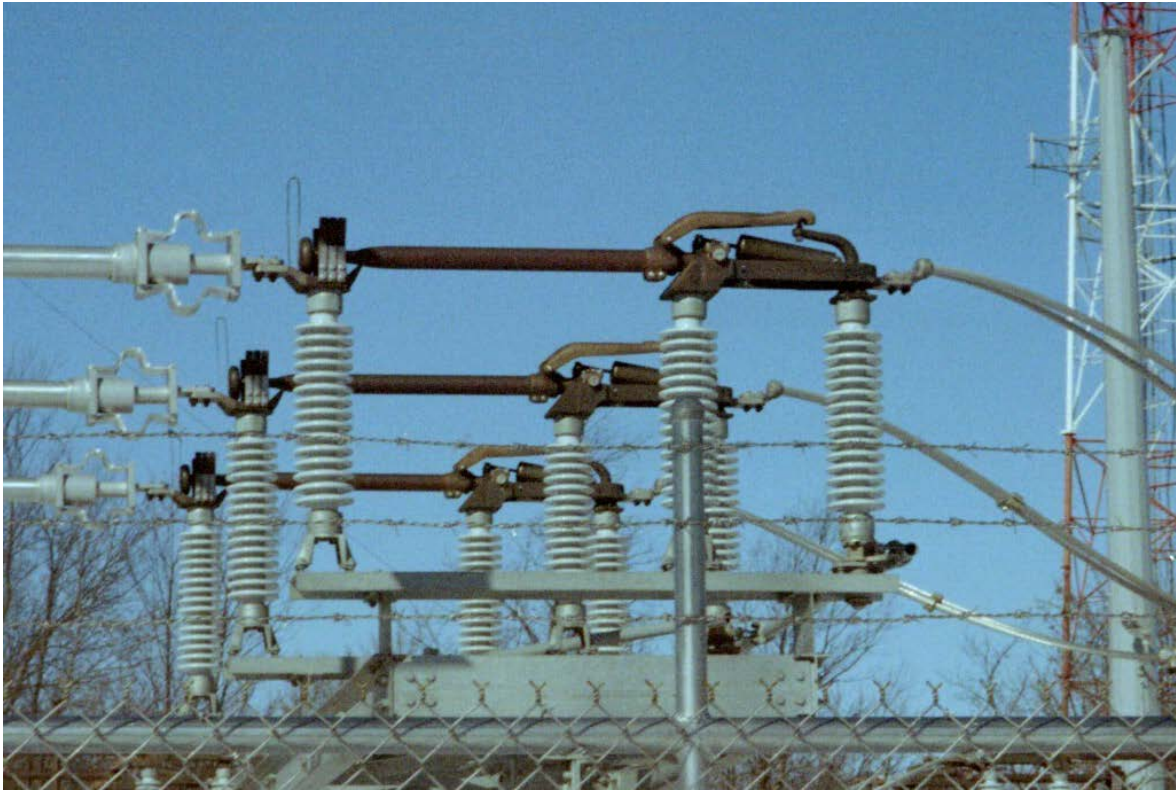

The Quality Name in High Voltage Switching

# Table of Contents

<b>Chapter</b>	<b>Page</b>
Table of Contents .....	VI
List of Tables and Figures .....	VII
Summary & Introduction .....	1
Summary .....	1
Important .....	1
Introduction .....	2
Ratings .....	3
Product Description .....	4
Typical Disconnect Switch .....	4
Receiving, Handling & Storage .....	5
Unpacking .....	5
Storage .....	5
Installation & Adjustment Procedures .....	6
Recommended Tools & Values .....	6
Preferred Switch Assembly Method: .....	7
Removal of Live Parts .....	7
Stack Insulators .....	8
Mounting Live Parts on Insulators .....	9
Adjustment of Switch in Open Position .....	9
Adjustment of Switch in Closed Position .....	10
Adjust Blade on Front Stop .....	11
Mounting Switch on Structure .....	12
Single Pole Adjustments .....	12
Arcing Horn Adjustment .....	13
Operating Mechanism .....	14
Operating Mechanism Adjustment (Three Phase Installation) .....	17
Final Switch Adjustments (Tuning) .....	19
General Instructions for Threaded Clevises .....	22
Recommended Inspection Maintenance .....	23

The Quality Name in High Voltage Switching

## List of Tables and Figures

### **Tables** **Page**

Table 1: Ratings Table .....	3
Table 2: Recommended Tools and Torque Values .....	6

### **Figures** **Page**

Figure 1: Typical CVB-2 Single Pole Switch & Common Terminology .....	4
Figure 2: Blade shown fully open for horizontal mounting .....	7
Figure 3 .....	8
Figure 4 .....	9
Figure 5 .....	11
Figure 6 .....	12
Figure 7 .....	14
Figure 8 .....	15
Figure 9: Typical Operating Pipe Arrangement .....	16
Figure 10: Typical Operating Arrangement .....	16
Figure 11: Top View of Adjustable Arm Assembly .....	17
Figure 12: Piercing Pipe Wall .....	18
Figure 13: Type HOGO (High Output Geared Operator) Front View .....	19
Figure 14: Type SEGO (Safety Enhanced Gear Operator) Front View .....	20

---

## Summary & Introduction

# Summary & Introduction

### Summary

These instructions do not intend to cover all details or variations in equipment, or provide for every possible contingency to be met in connection with installation, operation or maintenance. Should information be desired or should particular problems arise which are not covered sufficiently for the purchaser's purposes, the matter should be referred to the local Southern States Representative.

The contents of this instruction manual should not become part of or modify any prior or existing agreement, commitment or relationship. The sales contract contains the entire obligations of Southern States. The Warranty contained in the contract between the parties is the sole warranty of Southern States. Any statements contained herein do not create new warranties or modify the existing warranty.

### Important

The information contained herein is general in nature and not intended for specific application purposes. It does not relieve the user of responsibility to use sound practices in application, installation, operation, and maintenance of the equipment purchased. Southern States reserves the right to make changes in the specifications shown herein or to make improvements at any time without notice or obligations. Should a conflict arise between the general information contained in this publication and the contents of drawings or supplementary material, or both, the latter shall take precedence.

---

## Summary & Introduction

### Introduction

Southern States Type CVB-2 switch is a three-pole, single-throw, three insulator, end rotating stack, vertical break, group operated, outdoor air disconnect switch.

The current carrying parts are of copper alloy with copper-to-copper sealed threaded hinge current transfer points and silver-to-silver current transfer points at the jaw end. Due to their unique structure, reverse loop contacts on the jaw end of this switch provide high-pressure contact when subjected to high currents.

The Type CVB-2 switch also features weatherproof rotating insulator bearings, positive stops on each switch pole in the open and closed positions, insulator leveling bolts (72.5 kV and above) at each insulator stack and double channel bases (121 kV and above).

The instructions contained within this manual are necessary for the safe installation, maintenance, and operation of the Type CVB-2 switch. A qualified person, familiar with this of type equipment, should carefully read and follow the instructions.

These instructions are intended to provide a general guideline for the installation, adjustment, and maintenance of the Type CVB-2 switch. All details, equipment variations, and potential conditions may not be covered in this manual. Contact Southern States, LLC in the event conditions associated with a specific application are not sufficiently addressed.

All photographs and sketches in this manual are for illustration purposes only and may not be to scale. Refer to the Unit Assembly drawing or the Operating Mechanism drawing provided with each disconnect switch for specific details. During installation, it may be necessary to make adjustments other than those described in this manual. Contact your local representative or the factory if questions should arise.

Southern States After Sales and Service Department is available for field installation assistance along with providing parts support for all Southern States products.

Contact After Sales and Service at 770-946-4562, 7:30am-4:00pm EST Monday-Friday.

After Hours: 770-946-4565

Distinctive signal words are used to indicate the degree of hazard that may be encountered by the user. Identification of the signal words and their definition follow:

**▲ DANGER**

Indicates an imminently hazardous situation, which, if not avoided, will result in death or serious injury.

**▲ CAUTION**

Indicates a potentially hazardous situation, which, if not avoided, may result in minor or moderate injury. It may also be used to alert against unsafe

**▲ WARNING**

Indicates a potentially hazardous situation, which, if not avoided, could result in death or serious injury.

## Summary &amp; Introduction

**Ratings**
**Table 1: Ratings Table**

RATINGS								
Maximum Voltage Rating (kV)								
15.5	27	38	48.3	72.5	123	145	170	245
BIL (kV)								
110	150	200	250	350	550	650	750	900/1050

ADDITIONAL RATINGS	
Rated Power Frequency	60 Hz
Continuous Current	2000 A
Short-Time Symmetrical Withstand (3 Sec.)	63 kA RMS
Peak Withstand	164 kA
Ambient Temperature Rating	-40°C to +50°C Standard -50°C Optional

## Product Description

### Typical Disconnect Switch

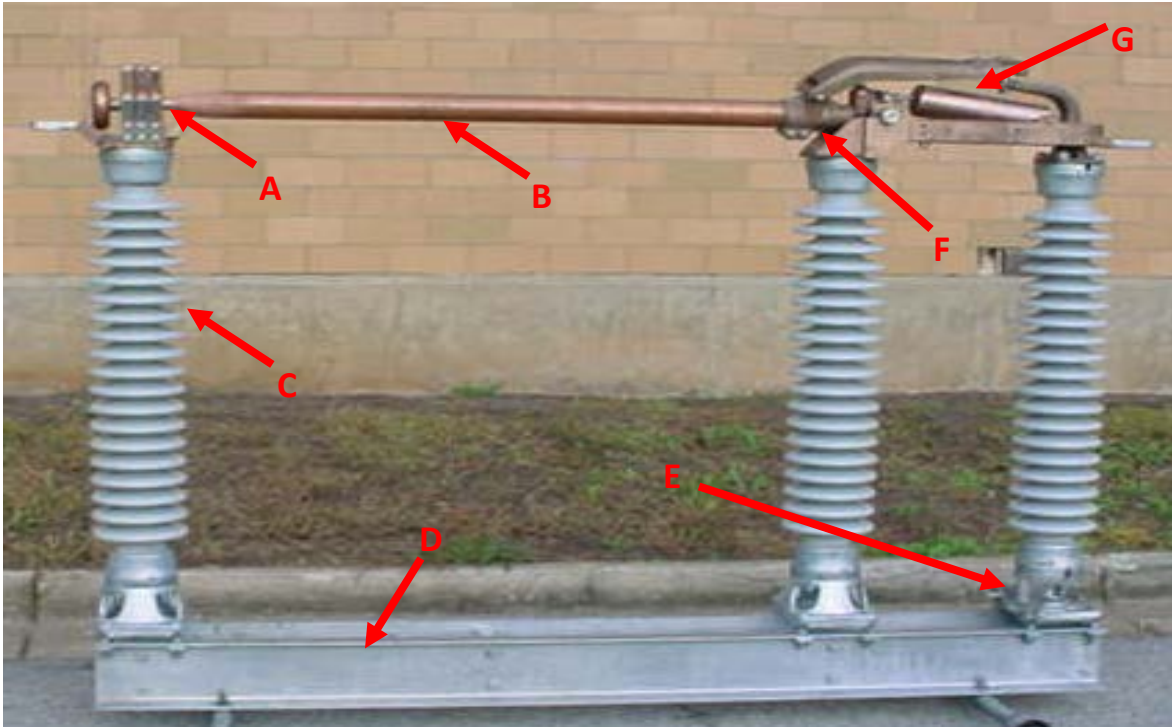

**Figure 1: Typical CVB-2 Single Pole Switch & Common Terminology**

- A. Jaw and blade tip – Reverse loop jaw contact fingers with silver-to-silver current transfer surfaces.
- B. Blade – Hard drawn, bus copper tubing.
- C. Insulators
- D. Switch base
- E. Insulator bearing – Low friction, maintenance free.
- F. Live part mechanical components – All copper
- G. Counterbalancing – Maintenance free coil spring, enclosed housing.

---

## Receiving, Handling & Storage

# Receiving, Handling & Storage

## Unpacking

The CVB-2 switch consists of: Live parts – blades with hinges, terminal pads and contacts; base housing with mounting angles attached; insulators; interphase and control pipes with hardware; and outboard bearing and operator.

Unpack the equipment and check for damages or material shortages immediately. The bill-of-materials from the Unit Assembly (switch) and Operating Mechanism drawings should be used for this purpose. If damage or a shortage is noted, file a claim immediately with the carrier and contact the factory.

## Storage

All components of the CVB-2 vertical break disconnect switch are suitable for outdoor use. Keep bearings out of standing water. Keep upright and support live parts with base. If a motor operator is furnished, be sure to connect the heater circuit using the provided external wiring, while the unit is in storage. Discard the wiring upon installation.

*Typical crating is intended for storage less than 1 year.* If long term storage is required please notify factory at time of order placement so that special crating can be used.

## Installation &amp; Adjustment Procedures

## Installation & Adjustment Procedures

### Recommended Tools & Values

**Table 2: Recommended Tools and Torque Values**

Recommended Tools		Recommended Torque Values	
Type	Sizes	Bolt/Nut size	Torque (Ft-lb)
Hand Wrenches and/or Sockets	15/16", 3/4", 5/8", 9/16"	1/2"	50 (S. Steel) 40 (All Others)
Drill Bit	1/4"	5/8"	92
		3/4"	127
		1"	286

## Installation & Adjustment Procedures

### Preferred Switch Assembly Method:

**When insulators are shipped installed on the switch and the switch has been adjusted at the factory, proceed to Mounting Switch on Structure.**

- Set up bases at ground level on transverse beams. Make sure the base support beams are level and then secure the switch bases to them so that during adjustment the switch does not tip over. They are top heavy in most cases after assembly of the insulators. Take care not to scratch the switch as scratching can cause corona!

#### Removal of Live Parts

- **Note: The hinge assembly is spring loaded—handle with caution.** Open blade fully before removing live parts (See **Figure 2**), except for vertical or underhung mounting switches. For vertical or underhung mounting switches leave the blade in the closed position when removing. Use a rope or non-metallic strap secured to the strut to lift by hand.

**⚠ CAUTION** OSHA requirements or other regulations may not permit some parts to be lifted by one man.



**Figure 2: Blade shown fully open for horizontal mounting**

---

## Installation & Adjustment Procedures

### Stack Insulators

- Consult your single-pole assembly and single-pole sub-assembly drawings for proper position of levers, spacers, etc. Sort out hardware, and then mount the insulators.

**Leave all bolts snug—do not tighten!**



**Figure 3**

## Installation & Adjustment Procedures

### Mounting Live Parts on Insulators

- Horizontal Mounted Switch
  1. After stacking insulators, turn the rear-rotating insulator counterclockwise to the fully open position against the bearing stop. Mount the live parts with the blade still in the fully open position (See **Figure 3**). Lift the hinge end live parts with the strut.
  2. Tighten lower bolts on rear rotating insulator stack.

**⚠ CAUTION** Do not use the blade or fork as a lifting point for the live parts. The hinge end of this switch has threaded contact joints and may be damaged if lifted improperly.

- Vertical or Underhung Mounted Switch  
Follow the above procedure except:
  1. Turn the rear, rotating insulator clockwise against the bearing stop to the fully closed position.
  2. Mount the live parts with the blade in the closed position.

### Adjustment of Switch in Open Position

1. Horizontal Mounted Switch  
Refer to the single-pole sub-assembly drawing for the correct angle of blade opening. If adjustment is required, use the open position stop cam on the strut to adjust the blade until it is at the required angle (See **Figure 4**). Now tighten upper rear rotating insulator bolts.



**Figure 4**

---

## Installation & Adjustment Procedures

### 2. Vertical or Underhung Mounting Switch

Rotate the rear insulator stack to open the single pole. Refer to the single-pole sub-assembly drawing for the correct angle of blade opening. If adjustment is required, use the open position stop bolt on the strut to adjust the blade until it is at the required angle (See **Figure 4**).

### Adjustment of Switch in Closed Position

With the insulator mounting bolts still loose (except the rotating insulator), check if the blade enters the contacts squarely. If not, align with the jacking screws. Now tighten all bolts. Open and close blade to check if blade enters contact in center. If it is off center, use jacking screws to realign. If that does not help, it may be necessary to loosen hinge end stack bolts to aid in alignment.

## Installation & Adjustment Procedures

### Adjust Blade on Front Stop

- Blade should touch stop as blade contact begins wiping motion with jaw contacts. This adjustment is made at the factory and should not need correcting in the field.; however, due to variation of the insulators, spacers, or the addition of ground switches or interrupter attachments which were not part of the original order a change may be necessary.
- To make the adjustment, loosen the set screws on the fork (See Figure 4.) and using the ball socket screws, either move the ball stud out to increase the effective fork length or in to decrease the effective fork length. Increasing the effective fork length increases the toggle pressure and starts the wiping action of the blade sooner. Decreasing the effective fork length does the opposite. A special tool is needed for this adjustment. Contact factory.
- Both ball socket screws must be tight to maintain proper pressure on the ball joint. Retighten the set screws.
- The blade is in correct alignment if contact is within 3°max. over-travel or under-travel of center (See **Figure 5**).



**Figure 5**

## Installation & Adjustment Procedures

### Mounting Switch on Structure

**▲ CAUTION** Rigging used to lift the poles should be attached to the base! Lift poles onto structure, making sure the pole is in the closed toggle position. It may be desirable to tie the fork to the strut to ensure the blade does not come open during lifting. Refer to the control arrangement drawing for proper placement of switch poles.

1. Tie blades in closed position to prevent switch from opening while lifting.
2. Rigging used to lift the poles should be attached to the clip angles or bearing housings. **Do not lift switch by attaching to the live parts.** Refer to the Operating Mechanism Drawing for proper placement of switch on the structure.
3. Check mounting surface for unevenness. Switch bases will warp on uneven surfaces. Use shims under base to level if necessary.
4. **Bolt bases solidly to structure.**

### Single Pole Adjustments

Be sure each single pole is properly adjusted before connecting the controls and operators.

1. With the switch bolted to the structure, check to make sure that the single-pole opening is as specified in the single-pole sub-assembly drawing. If readjustment is required, refer to Part 1, Item F.
2. Check blades entering contacts – be sure the center of the blade is in line with the contact-shoe pins.
3. Check to see that the blade is horizontal in the contacts  $\pm 3$  degrees. Refer to **Figure 5**.
4. Full open and close positions of switch pole are determined by positions of bearing stops. Allow 1/16-inch clearance on each stop. Refer to **Figure 6**.



**Figure 6**

---

## Installation & Adjustment Procedures

5. Re-inspect the single pole operation after bus or cable is attached to the terminal pads. Weight and possible side forces created by the bus or cable may require repeating some of the adjustments.

### Arcing Horn Adjustment

Check to see that the blade makes contact against the stationary horn above the contact shoes and maintains contact all the way down to the bottom of the blade stroke. The stationary horn may be bent by hand until it makes contact as stated above.

1. With the switch bolted solidly to the structure, check to make sure that the single pole opening is as specified in the single pole assembly drawing.
2. Check blades to be sure they contact squarely and smoothly. If they do not, refer to **Preferred Switch Assembly Method:** section.
3. After connecting the bus, all adjustments should be rechecked.

## Installation & Adjustment Procedures

### Operating Mechanism

Manual or Motor Operated

- These switches are designed to be opened and closed as a three-phase unit by a system of pipes that translates the rotational movement of an operator on the ground (whether manual or motor) to simultaneous rotation of the end insulator of each switch pole.
- **Figure 7** shows a typical operating mechanism for a 121 kV vertical break switch. **Figure 8** shows alternate operating mechanism designs, each of which is employed as being the simplest arrangement for a given structure. In all cases, however, the operating principle remains the same and the methods of installation and adjustment are virtually identical.



**Figure 7**

## Installation & Adjustment Procedures

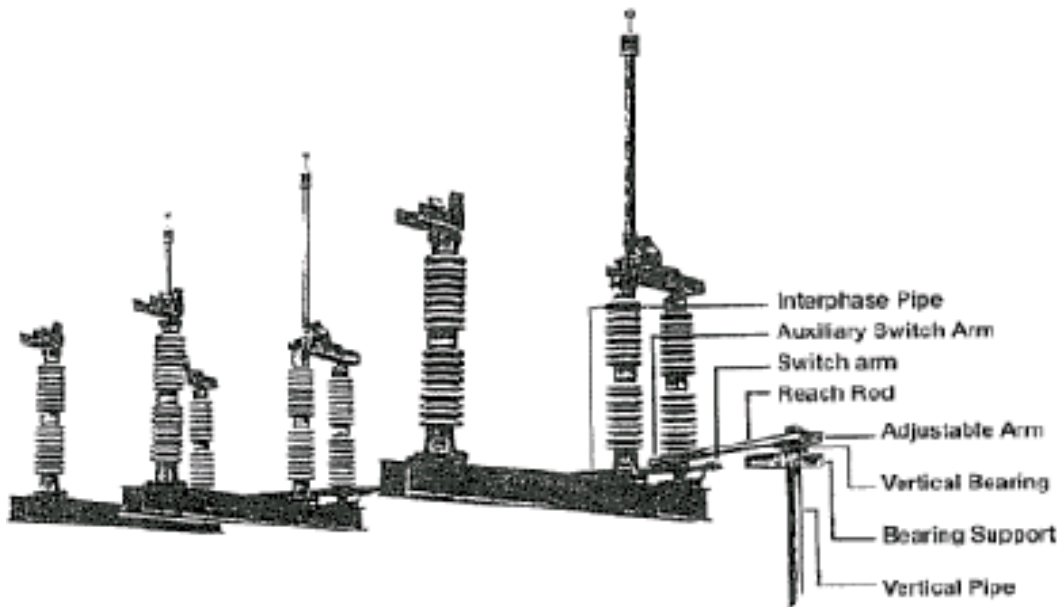

**Figure 8**

Refer to the Operating Mechanism Drawing provided with your switch and follow these steps:

- Have all switch poles completely closed. Install all components shown on the Operating Mechanism Drawing, including interphase pipe, vertical pipe, all brackets, bushings, etc., and the adjustable crank arm.

**▲ CAUTION** The Pipe Collar must support the entire weight of the Vertical Operating Pipe. Do not allow the manual operating housing to bear any of the Vertical Pipe weight.

Installation & Adjustment Procedures

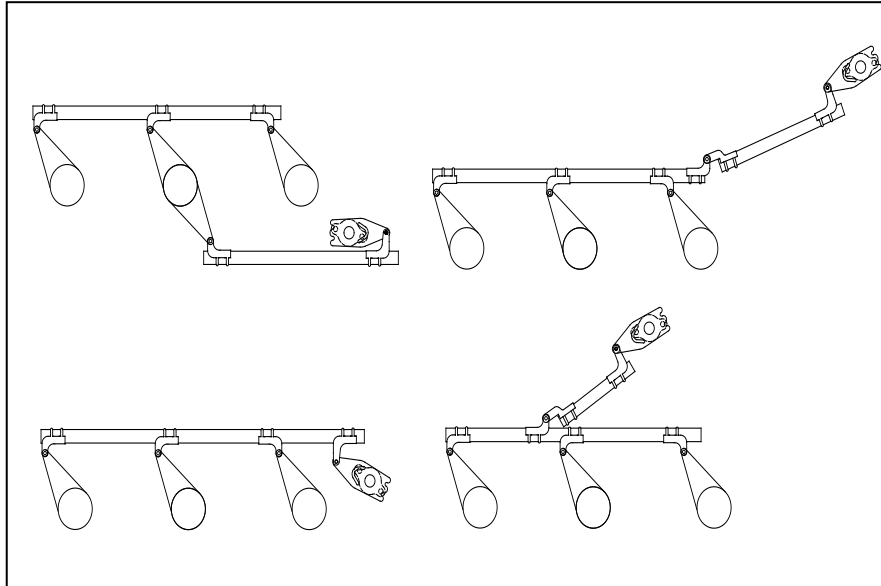

**Figure 9: Typical Operating Pipe Arrangement**

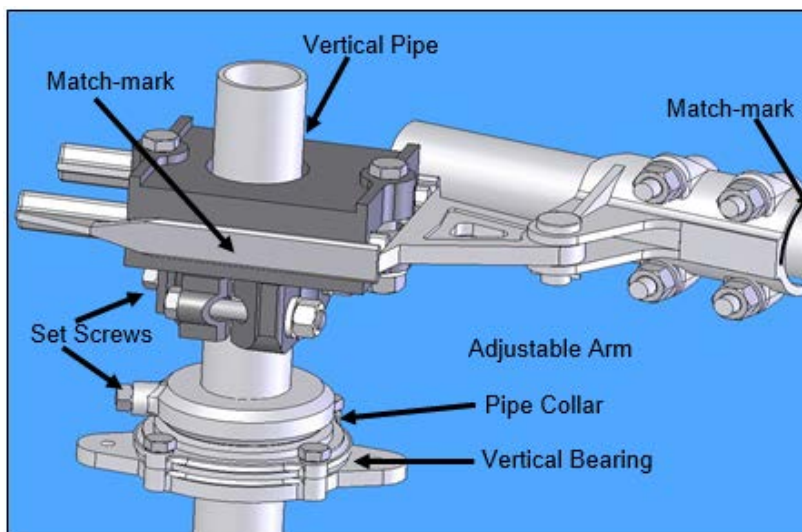

**Figure 10: Typical Operating Arrangement**

- **GENERAL INSTALATION NOTE:** When a switch uses an auxiliary switch arm, installation will be easier if this pole is adjusted before installing the interphase pipe. This will eliminate trying to coordinate and adjust all three poles at once.

## Installation & Adjustment Procedures

- **GENERAL INSTALLATION NOTE:** If the components have self-piercing set screws, during installation tighten them to only grip the pipe (match mark to check for slippage) and drive them in only after adjustments are completed.
- If a motor operator is used, at this point refer to its installation instructions for mounting, checkout procedure, and trial operations.

### Operating Mechanism Adjustment (Three Phase Installation)

1. Position all Grounding Switch poles closed and all Disconnect Switch poles open.
2. The Adjustable Arm setting on the Op-Mech Drawing is a calculated dimension. Adjust as required for exact setting.
3. The Adjustable Arm radius is **too short** if the Grounding Switch does not open fully (Blade in horizontal position). To correct:
  - Check for slippage
  - Return the switch to the closed position.
  - Operate the switch toward the open position to remove pressure on the linkage.
  - Loosen Adjustable Arm and Clevis Bolts - **Figure 11**.

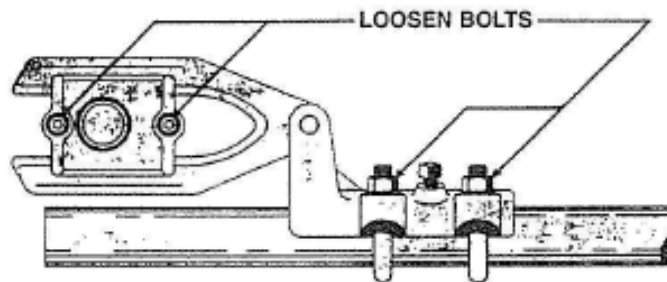

**Figure 11: Top View of Adjustable Arm Assembly**

- Lengthen the Adjustable Arm radius approximately  $\frac{1}{4}$ ". Shorten the pipe to allow the Clevis to reposition itself the same distance.
- Re-tighten the Adjustable Arm and Clevis Clamping Bolts.
- Test Operate. Re-adjust as necessary.

## Installation & Adjustment Procedures

4. The Adjustable Arm radius is **too long** if the Grounding Switch reaches the fully open position (Blade in horizontal position) before the switch operator reaches the open position. To correct:
  - Check for slippage
  - Return the switch to the closed position.
  - Operate the switch toward the open position to remove pressure on the linkage.
  - Loosen Adjustable Arm and Clevis Bolts - **Figure 11**.
  - Shorten the Adjustable Arm radius approximately  $\frac{1}{4}$ ". Lengthen the pipe to allow the Clevis to reposition itself the same distance.
  - Re-tighten the Adjustable Arm and Clevis Clamping Bolts.
  - Test Operate. Re-adjust as necessary.
5. All poles of the fully adjusted switch should close completely and operate together. Slight adjustment of the Hinge Assembly Clamping Bolts may be necessary to coordinate all three poles. Rapid operation of the manual handle may be necessary to achieve full closing of all three poles.
6. No adjustment of the Grounding Switch Blade closest to the Operating Arm is necessary.
7. When the switch is fully adjusted:
  - Pre-drill pipe for setscrews with the Threaded Drill Guides supplied and a  $\frac{1}{4}$ " drill.
  - Securely tighten all bolts.
  - Tighten setscrews until pipe wall is pierced - **Figure 12**

### CAUTION

Penetrate the aluminum pipe only with setscrews. Forcing setscrews into the steel pipe can result in casting breakage.

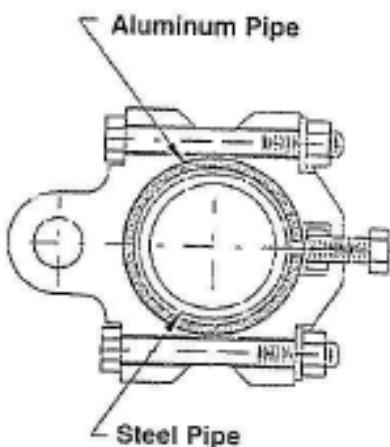

**Figure 12: Piercing Pipe Wall**

## Installation & Adjustment Procedures

### Final Switch Adjustments (Tuning)

1. The operating mechanism is intended to fully open and fully close the disconnect switch by rotating the vertical operating pipe about 180° using an operator (manual or electrical). The interphase pipe controls the individual operation of each switch pole, using a push/pull control. The reach rod translates the motion of the vertical operating pipe to the interphase linkage. The adjustable arm controls the total amount of switch operation available.

**HINT:** For easiest adjustment start with the reach rod connected to the drive phase and the interphase pipe disconnected from the other two phases. Once the drive phase is properly adjusted, connect the interphase pipe and continue tuning the other two phases, one at a time.

2. Switch Operating Devices:

- 2.1. Worm gear operator (HOGO – High Output Geared Operator) (Optional)

- 2.1.1. The weight of the vertical operating pipe should be supported by pipe collar by maintaining the 1/4" - 3/8" gap (**Figure 13**).
- 2.1.2. When the switch is properly adjusted the operator handle should hang freely in both the open and closed positions to permit the use of a customer supplied padlock. Refer to **Figure 13**.

**CAUTION** Be aware that there is an adjustable stop on the operator. **Do not over operate as damage will occur to the operator.**

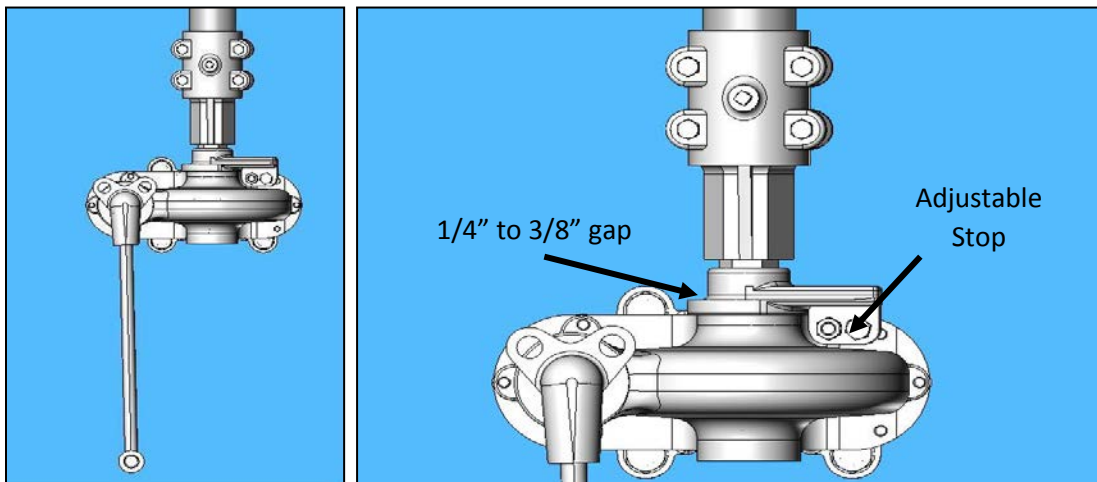
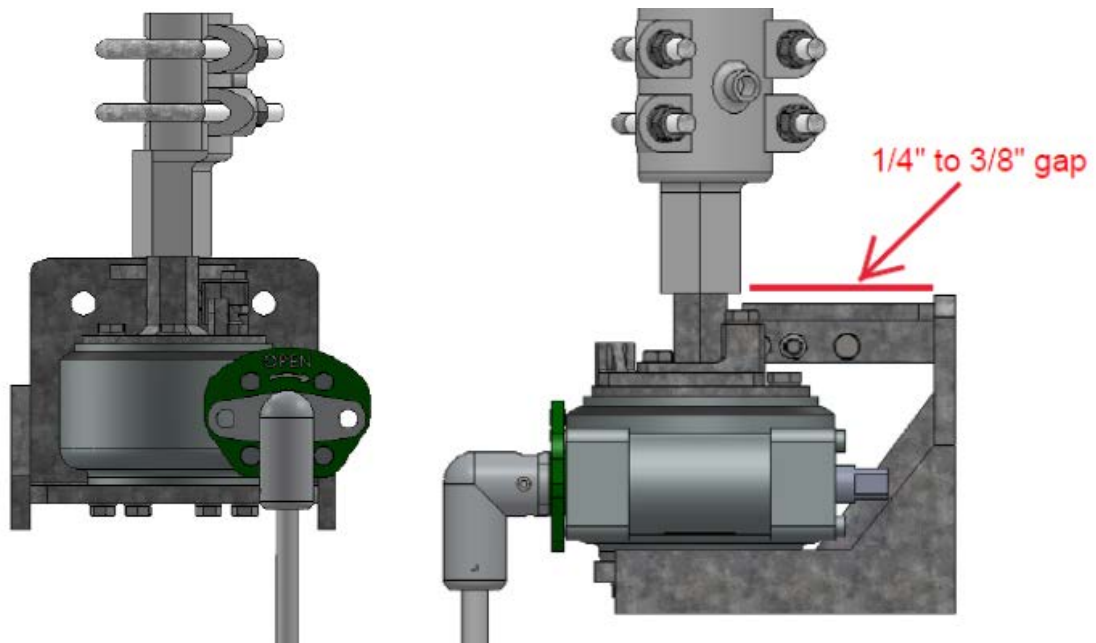

**Figure 13: Type HOGO (High Output Geared Operator) Front View**

## Installation & Adjustment Procedures

- 3.1. Worm gear operator (SEGO – Safety Enhanced Gear Operator) (Optional)
  - 3.1.1. The weight of the vertical operating pipe should be supported by pipe collar by maintaining the 1/4"-3/8" gap (**Figure 14**).
  - 3.1.2. When the switch is properly adjusted the operator handle should hang freely in both the open and closed positions to permit the use of the customer supplied padlock.

**CAUTION** Be aware that there is an adjustable stop on the operator. Do not over operate as damage will occur to the operator.



**Figure 14: Type SEGO (Safety Enhanced Gear Operator)**

---

## Installation & Adjustment Procedures

### 4.1. Swing handle operator

- 4.1.1. When the switch is properly adjusted the handle should hang vertically and free in both the open and closed positions to permit the use of a customer supplied padlock.

### 5.1. Electrical motor operator

- 5.1.1. Please refer to motor operator instruction manual for proper installation and setup.
- 5.1.2. Use manual operation while completing switch setup.
- 5.1.3. **Do not** electrically operate until all switch adjustments are complete. **ALWAYS** operate the motor operator decoupled first to ensure proper setup.

## General Instructions for Threaded Clevises

### General Instructions for Threaded Clevises

When threaded clevises are specified, one is generally attached to the adjustable arm, and two more to the center phase switch arm (refer to the plan view of the operating mechanism drawing and the illustration below).

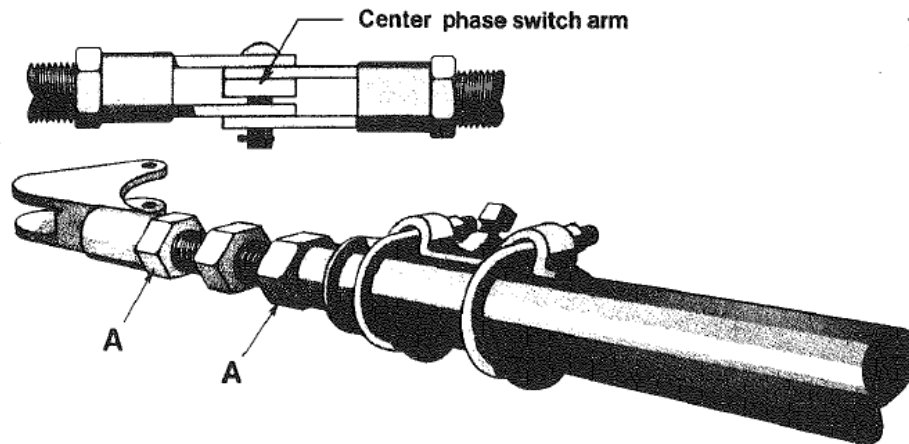

Operating mechanism adjustments consist mainly of incremental lengthenings and/or shortenings of the pipe that connect the switch arms together. To make these adjustments, simply loosen both jam nuts "A" and screw the stud in or out as required. Be sure to retighten both jam nuts securely.

**▲ CAUTION ▲ DANGER** Do not screw the stud out of the clevises. This could cause the pipe to fall, resulting in serious injury to personnel below.

Be sure the initial setting is correct, and do not adjust beyond the maximum allowable dimension. If adjustment beyond the maximum allowable dimension is needed loosen the U-bolts on the outboard phase clevis and reposition the pipe toward the center phase.

Initial dimension for  $\frac{3}{4}$ " stud is  $1\frac{11}{16}$ "; 1" stud is  $\frac{1}{2}$ ".

Maximum allowable for  $\frac{3}{4}$ " stud is  $1\text{-}\frac{3}{16}$ ".  
Maximum allowable for 1" stud is 1".

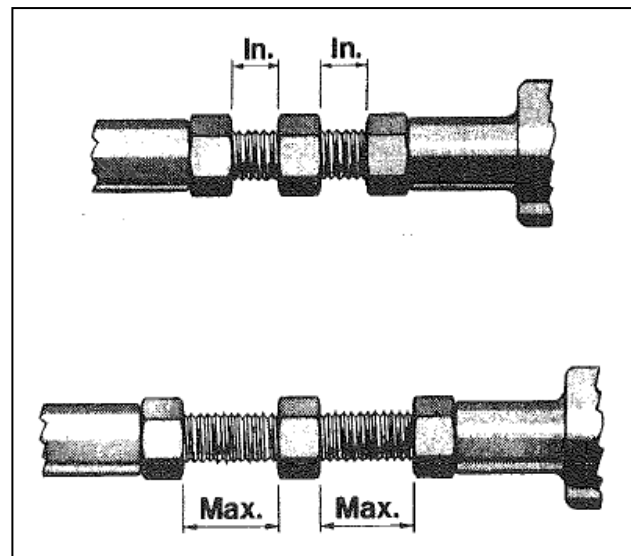

---

## Recommended Inspection Maintenance

### Recommended Inspection Maintenance

Failure to properly maintain the equipment can result in severe personal injury and product damage. The following maintenance procedures must be performed regularly and do not represent an exhaustive survey of all maintenance steps necessary to ensure safe operation of the equipment. Particular problems that may arise should be referred to the local Southern States, LLC, representative.

1. The switch should be cleaned periodically to remove contaminant particles that have been on the switch. Cleaning after installation is recommended to remove dirt or other contaminants that have been deposited on the switch during shipment or storage.
2. Check for loose bolts and nuts; tighten as needed.
3. Examine the contact surfaces for wear or pitting.
  - a. Slightly damaged surfaces of the male blade plus can be smoothed with a burnishing tool or crocus cloth. Do not burnish or sand female blades.
  - b. If severe damage has occurred, replace the damaged part with Southern States replacement parts.
  - c. Examine the switch blade contact alignment and realign if necessary.
4. Check all galvanized surfaces for chips. If chipping has occurred, use a zinc rich paint or cold galvanizing spray for touchup.
5. Verify Operating Mechanism establishes full open and closed positions of the switch live parts.
6. Before energizing switch, be sure to follow ANSI/IEEE C37.35 "Guide for the Application, Installation, Operation and Maintenance of High-Voltage Air Disconnecting and Load Interrupter Switches". Pay particular attention to section 5.11 "Inspection".





**The Quality Name in High Voltage Switching**

30 Georgia Avenue  
Hampton, Georgia 30228  
Phone: 770-946-4562  
Fax: 770-946-8106  
E-mail: [support@southernstatesllc.com](mailto:support@southernstatesllc.com)  
<http://www.southernstatesllc.com>

©2017 Southern States, LLC  
IB-105-CVB2 245- R5 060217 Printed U.S.A.