



TYPE CBL-T

Copper Center Break “V”
Disconnect Switch

15.5 – 72.5 kV, 1200A

INSTALLATION &

INSTRUCTION

MANUAL

Safety Information

DANGER

IMPROPER HANDLING, INSTALLATION, OPERATION OR MAINTENANCE OF THIS EQUIPMENT MAY CAUSE IMMEDIATE HAZARDS WHICH WILL LIKELY RESULT IN SERIOUS PERSONNEL INJURY OR DEATH.

WARNING

The equipment covered by this publication must be handled, installed, operated and maintained by qualified persons who have direct knowledge and experience dealing with the hazards involved and are thoroughly trained in the handling, installation, operation and maintenance of high voltage transmission and distribution equipment. These instructions are meant for only such **Qualified Persons**. They are not intended to be a substitute for adequate training and experience in safety procedures for this type of equipment.

A **Qualified Person** is one who is trained in and has skills necessary:

- to read and comprehend this instruction book – understanding that these instructions are general in nature
- to accept personal responsibility to prepare and maintain an intrinsically safe work environment and maintain control of the work site to safeguard all persons present
- to develop and implement a proper rigging, lifting, and installation plan along with all safety precautions required to insure safe and proper lifting and installation of the equipment.
- to distinguish between energized and non energized parts
- to determine proper approach distances to energized parts
- to properly work with and around energized or de-energized equipment that may be pressurized with gas
- for proper use of personal protective equipment, insulating and shielding materials, insulated tools for working near energized and /or pressurized electrical equipment
- to recognize and take necessary precautions for the unique and dynamic conditions of site and specialized equipment to maintain a safe work environment during handling, installation, operation, and maintenance of high voltage switching equipment

The instructions in this manual are general guidelines for this type of equipment and not specific to the equipment supplied. Portions of it may not be applicable or may not have complete instructions for your specific equipment.

If you do not understand any part of these instructions or need assistance, contact Southern States Service Division at 770-946-4562 during normal business hours (EST) or 770-946-4565 after normal business hours.

LIMITED WARRANTY

Southern States, LLC (“SLLC”) warrants only to the Warranty Holder (hereinafter defined as the “End User” or the “Immediate Purchaser”, as applicable, pursuant to the terms and conditions of this Limited Warranty as set forth below), that the Product identified below will, upon shipment, be free of defects in workmanship and material for the applicable Warranty Period. The “Warranty Period” is that period of time during which this Limited Warranty is effective, and such period begins on the invoice date issued by SLLC for the Product, and continues until the earlier to occur of (1) the expiration of the Warranty Duration period, or (2) the Number of Operations, both as specified in the table below. If the Product is both purchased and installed within the United States or Canada, this Limited Warranty is granted to each end user of the Product who acquired the Product for its own use during the Warranty Period (“End User”). In all other situations, this Limited Warranty is granted only to the first purchaser of the Product (“Immediate Purchaser”) from SLLC. No primary or remote purchaser or owner of the Product who is not a Warranty Holder may claim any benefit under this Limited Warranty, or any remedial promise included in this Limited Warranty. SLLC shall, upon prompt written notice from the Warranty Holder, correct a nonconforming Product by repair or replacement at the sole discretion of SLLC of the nonconforming Product or any part or component of a nonconforming Product necessary in SLLC’s discretion to make such Product conforming. Any transportation charges, labor for removing, reinstalling the Product or part, and/or costs related to providing access to the Product shall be the responsibility of the Warranty Holder. Correction in this manner will constitute the Warranty Holder’s exclusive remedy and fulfillment of all SLLC’s liabilities and responsibilities hereunder. SLLC’s duty to perform under this limited warranty may be delayed, at SLLC’s sole option, until SLLC has been paid in full for all products purchased by the Warranty Holder. No such delay will extend the Warranty Period. If SLLC does not make such repair or replacement, SLLC’s liability for damages on account of any claimed nonconformity will in no event exceed the purchase price of the Product in question. This Limited Warranty does not apply to any Product that has been disassembled, repaired, or altered by anyone other than SLLC. This Limited Warranty will not apply to any Product that has been subjected to improper or abnormal use of the Product. SLLC has no responsibility to repair or replace any Product or component thereof manufactured by another party, but SLLC will assign, to the extent assignable, to the Warranty Holder any manufacturers’ warranty that applies to products and components not manufactured by SLLC.

THIS LIMITED WARRANTY IS EXCLUSIVE AND IN LIEU OF ALL OTHER WARRANTIES. THERE ARE NO OTHER EXPRESS, IMPLIED, OR STATUTORY WARRANTIES. ALL IMPLIED WARRANTIES WHICH MAY ARISE BY IMPLICATION OF LAW, OR APPLICATION OF COURSE OF DEALING OR USAGE OF TRADE, INCLUDING, BUT NOT LIMITED TO, IMPLIED WARRANTIES OF MERCHANTABILITY OR FITNESS FOR A PARTICULAR PURPOSE, NONINFRINGEMENT OR OTHERWISE ARE EXPRESSLY EXCLUDED. SLLC SHALL NOT BE LIABLE OR RESPONSIBLE FOR ANY CONSEQUENTIAL, INCIDENTAL, INDIRECT, EXEMPLARY, SPECIAL, OR PUNITIVE DAMAGES, EVEN IF SLLC HAS BEEN ADVISED OF THE POSSIBILITY OF SAME. THE WARRANTY HOLDER IS SOLELY RESPONSIBLE FOR THE SUITABILITY OF THE PRODUCT FOR ANY PARTICULAR APPLICATION.

Product Purchased Region	Product Installed Region	Warranty Holder	Warranty Duration
U.S and Canada	U.S and Canada	End User	Five (5) Years
All Other Conditions		Immediate Purchaser	Earlier of 1 year from installation or 18 months from shipment

Type CBL-T

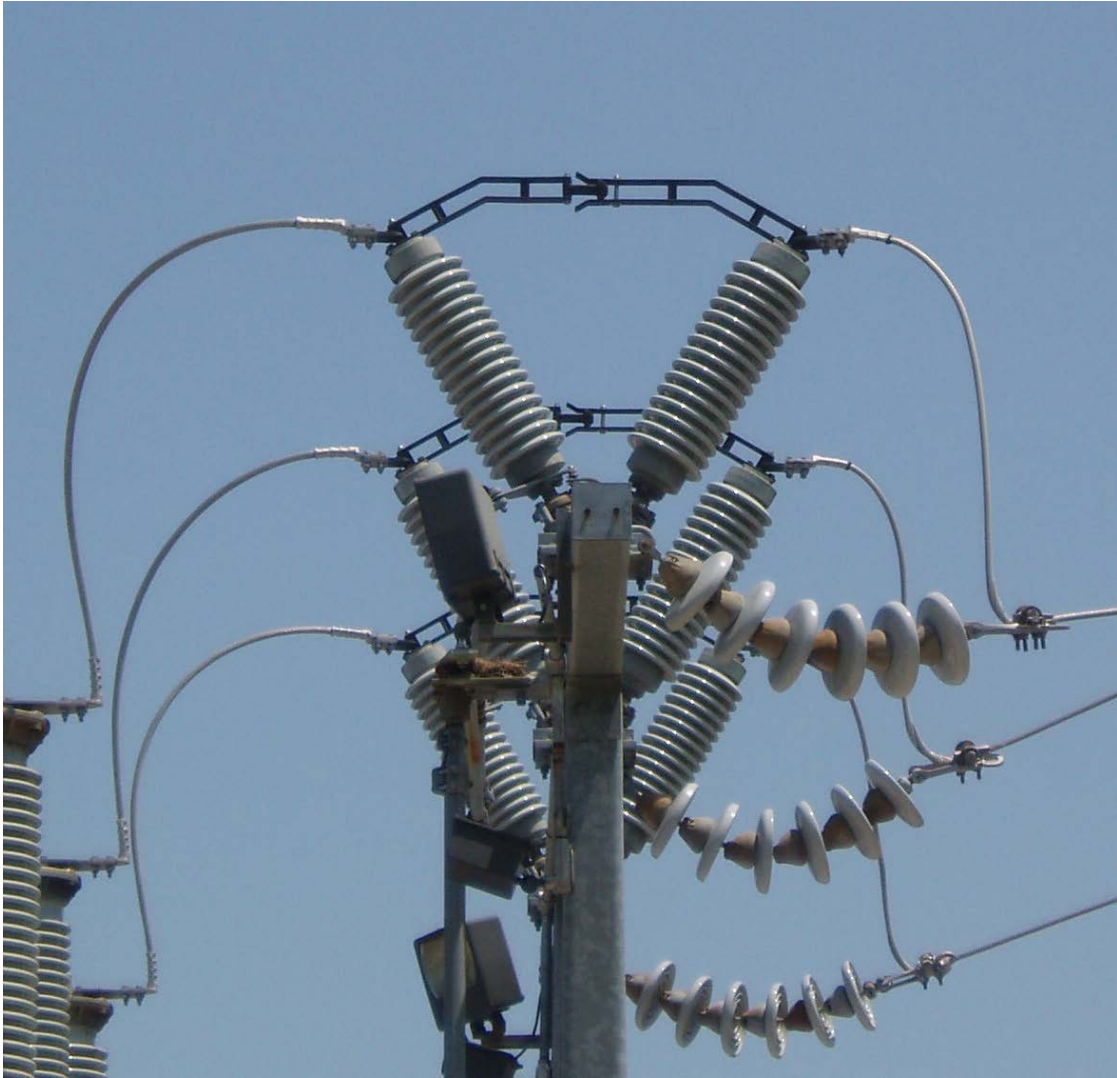

Table of Contents

Chapter	Page
Table of Contents	VI
List of Tables and Figures	VII
Summary & Introduction	6
Summary	6
Important	6
Introduction	7
Ratings	8
Product Description	9
Typical Disconnect Switch	9
Receiving, Handling & Storage	10
Unpacking	10
Storage	10
Installation & Adjustment Procedures	11
Recommended Tools & Values	11
Preferred Switch Assembly Method:	12
Mounting Switch on Structure	15
Single Pole Adjustments	15
Arcing Horn Adjustment	15
Operating Mechanism	16
Operating Mechanism Adjustment (Three Phase Installation)	19
Final Switch Adjustments (Tuning)	22
General Instructions for Threaded Clevises	24
Recommended Inspection Maintenance	25

List of Tables and Figures

Tables	Page
Table 1: Ratings Table	8
Table 2: Recommended Tools and Torque Values	11

Figures	Page
Figure 1: Typical CBL-T Single Pole Switch & Common Terminology	9
Figure 2: Live Parts Mounting	12
Figure 3: Rotating Insulator Bearing Housing	13
Figure 4: Blades Shown Fully Open	14
Figure 5: Contacts Shown Fully Closed	14
Figure 6: Optional Arcing Horn in Closed Position	16
Figure 7: Typical Operating Pipe Arrangement	17
Figure 8: Typical Operating Arrangement	17
Figure 9: Counterweight Assembled.....	18
Figure 10: Top View of Adjustable Arm Assembly	19
Figure 11: Match-Marked Hinge Clamp and Pipe	20
Figure 12: Piercing Pipe Wall	21
Figure 13: Type HOGO (High Output Geared Operator) Front View	22
Figure 14: Type SEGO (Safety Enhanced Gear Operator) Front View	23

Summary & Introduction

Summary

These instructions do not intend to cover all details or variations in equipment, or provide for every possible contingency to be met in connection with installation, operation or maintenance. Should information be desired or should particular problems arise which are not covered sufficiently for the purchaser's purposes, the matter should be referred to the local Southern States Representative.

The contents of this instruction manual should not become part of or modify any prior or existing agreement, commitment or relationship. The sales contract contains the entire obligations of Southern States. The Warranty contained in the contract between the parties is the sole warranty of Southern States. Any statements contained herein do not create new warranties or modify the existing warranty.

Important

The information contained herein is general in nature and not intended for specific application purposes. It does not relieve the user of responsibility to use sound practices in application, installation, operation, and maintenance of the equipment purchased. Southern States reserves the right to make changes in the specifications shown herein or to make improvements at any time without notice or obligations. Should a conflict arise between the general information contained in this publication and the contents of drawings or supplementary material, or both, the latter shall take precedence.

Introduction

Southern States Type CBL-T switch is a center side break, low profile “V” configuration disconnect switch for pole or structure mounting. It has two rotating insulators placed 60° apart and can be mounted upright, inverted, or at any desired angle. The current carrying parts are copper and copper alloy with silver-to-copper transfer points. Standard mounting dimensions are 9¾” x 9¾”.

The CBL-T is designed for simplicity, ruggedness, reliability and attractive appearances. Using only two insulators per phase results in cost and weight savings. All switches, including 69kV, are normally shipped factory assembled with insulators, and fully adjusted.

The CBL-T switch may be operated with either a manual operator (swing handle or worm gear) or a Southern States Type VM-1 Motor Operator

The instructions contained within this manual are necessary for the safe installation, maintenance, and operation of the Type CBL-T switch. A qualified person, familiar with this of type equipment, should carefully read and follow the instructions.

These instructions are intended to provide a general guideline for the installation, adjustment, and maintenance of the Type CBL-T switch. All details, equipment variations, and potential conditions may not be covered in this manual. Contact Southern States, LLC in the event conditions associated with a specific application are not sufficiently addressed.

All photographs and sketches in this manual are for illustration purposes only and may not be to scale. Refer to the Unit Assembly drawing or the Operating Mechanism drawing provided with each disconnect switch for specific details. During installation, it may be necessary to make adjustments other than those described in this manual. Contact your local representative or the factory if questions should arise.

Southern States After Sales and Service Department is available for field installation assistance along with providing parts support for all Southern States products.

Contact After Sales and Service at 770-946-4562, 7:30am-4:00pm EST Monday-Friday.
After Hours: 770-946-4565

Distinctive signal words are used to indicate the degree of hazard that may be encountered by the user. Identification of the signal words and their definition follow:

▲ DANGER

Indicates an imminently hazardous situation, which, if not avoided, will result in death or serious injury.

▲ CAUTION

Indicates a potentially hazardous situation, which, if not avoided, may result in minor or moderate injury. It may also be used to alert against unsafe practices.

▲ WARNING

Indicates a potentially hazardous situation, which, if not avoided, could result in death or serious injury.

Ratings

Table 1: Ratings Table

RATINGS					
MAXIMUM VOLTAGE (kV)	15.5	27	38	48.3	72.5
BIL (kV)	110	150	200	250	350
Rated Power Frequency	60 Hz				
Continuous Current	1200 A				
Short-Time Symmetrical Withstand (3 Sec.)	38 kA RMS				
Peak Withstand	99 kA				
Ambient Temperature Rating	-40°C to +50°C Standard -50°C Optional				

Product Description

Typical Disconnect Switch

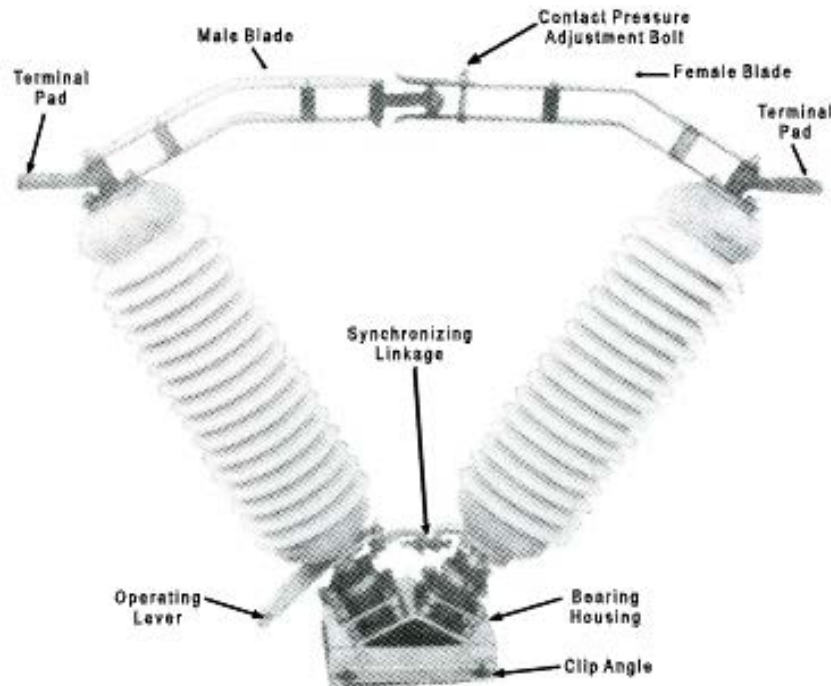

Figure 1: Typical CBL-T Single Pole Switch & Common Terminology

Contacts – The CBL-T switch has Silver-to-Copper contacts. A heavy silver insert, brazed on either side of the male contact, provides low resistance, high conductivity current transfer points. On the hinge end, silver rings are brazed to the terminal (hinge) assembly which make contact continuously with the copper truss blade.

Six Hole Terminal Pads – Provided as standard, the 6-hole terminal pads are suitable for either 2 or 4-hole connection on NEMA standard drilling patterns.

Compact Base – The base is simple and can be mounted almost anywhere. The base is galvanized steel and includes leveling screws for the insulators, adjustable open and close stops and mounting hole for attachment to the structure.

Bearings – The bearings on the CBL-T switch are stainless steel balls and races. They are rugged, maintenance free, life time bearings. All ratings are supplied with insulator leveling bolts.

Adjustable Open and Close Position Stops – These stops are provided on the rotating insulator stacks to provide individual adjustments, allowing maximum synchronization of the three phase assembly.

Receiving, Handling & Storage

Unpacking

The CBL-T switch consists of: Live parts – blades with hinges, terminal pads and contacts; base housing with mounting angles attached; insulators; interphase and control pipes with hardware; and outboard bearing and operator.

Unpack the equipment and check for damages or material shortages immediately. The bill-of-material from the Unit Assembly (switch) and Operating Mechanism drawings should be used for this purpose. If damage or a shortage is noted, file a claim immediately with the carrier and contact the factory.

Storage

All components of the Cole Type P center break disconnect switch are suitable for outdoor use. Keep bearings out of standing water. Keep upright and support live parts with base. If a motor operator is furnished, be sure to connect the heater circuit using the provided external wiring, while the unit is in storage. Discard the wiring upon installation.

Typical crating is intended for storage less than 1 year. If long term storage is required please notify factory at time of order placement so that special crating can be used.

Installation & Adjustment Procedures

Recommended Tools & Values

Table 2: Recommended Tools and Torque Values

Recommended Tools		Recommended Torque Values	
Type	Sizes	Bolt/Nut size	Torque (Ft-lb)
Hand Wrenches and/or Sockets	15/16", 3/4", 5/8", 9/16"	1/2"	50 (S. Steel) 40 (All Others)
Drill Bit	1/4"	5/8"	92
		3/4"	127
		1"	286

Installation & Adjustment Procedures

Preferred Switch Assembly Method:

1.3 When insulators are shipped installed on the switch and the switch has been adjusted at the factory, proceed to Mounting Switch on Structure

1. Set up bearing housing with clip angles installed at ground level. Make sure clip angles are level and secured so that the switch does not tip over when insulators are installed.
2. Bolt insulators to rotating flanges of bearing housing.
3. Install male blade to top of insulator with mounting bolts supplied (**Figure 2**). Note that male blade is on the same side as operating lever.

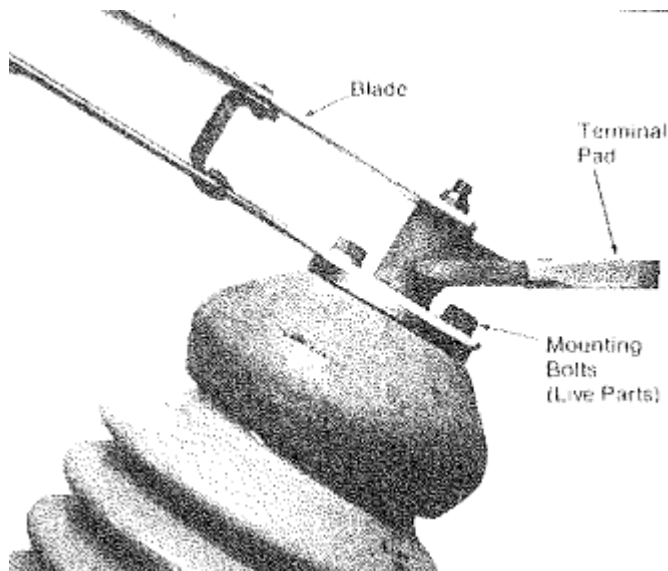

Figure 2: Live Parts Mounting

Installation & Adjustment Procedures

4. With male blade in closed position, adjust and level male blade plug to be centered over bearing housing. Use jacking bolts (**Figure 3**) to make these adjustments.

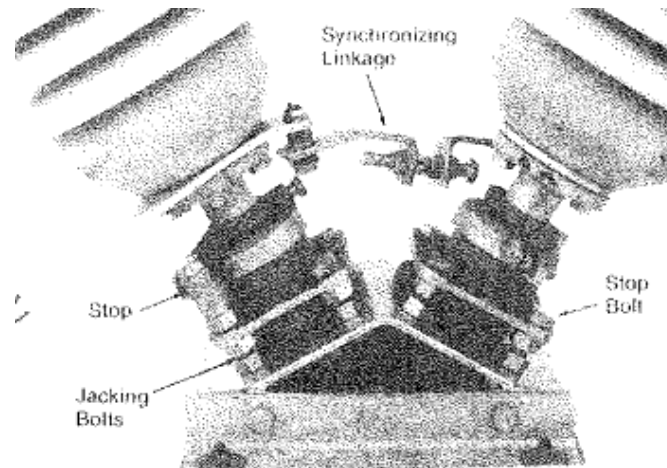
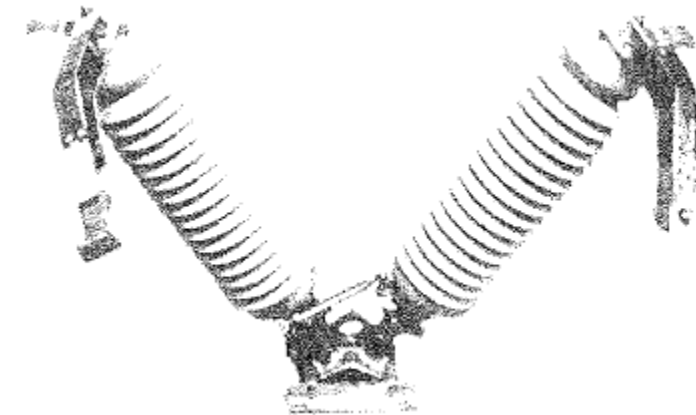

Figure 3: Rotating Insulator Bearing Housing

5. Install female blade, level and adjust to mate with male blade. The synchronizing linkage may require slight adjustment to ensure that both blades center together in the closed position. Set stop adjustment bolts on bearing housing for the closed position.
6. Adjustment of switch in the open position – Rotate the insulator stacks to the open position. The blades should travel 90 degrees. Set stops on bearing housing to provide 90 degree blade opening. Refer to **Figure 4**. Open position stop is on female blade side.



Installation & Adjustment Procedures

Figure 4: Blades Shown Fully Open

7. Adjustment of contact pressure – Rotate the blade assemblies into the closed position. The pressure adjusting bolt should be left loose so as not to apply any pressure during this first closing position. Tighten the adjusting bolt until the contact surfaces touch. Then tighten 1/8 turn. Refer to **Error! Reference source not found.**

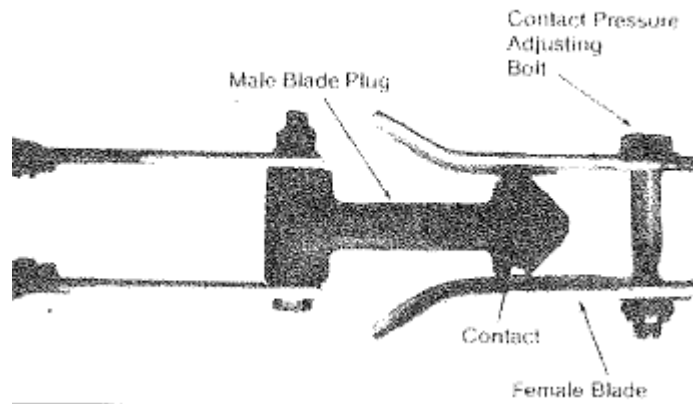

Figure 5: Contacts Shown Fully Closed

Installation & Adjustment Procedures

Mounting Switch on Structure

1. Tie blades in closed position to prevent switch from opening while lifting.
2. Rigging used to lift the poles should be attached to the clip angles or bearing housings. **Do not lift switch by attaching to the live parts.** Refer to the Operating Mechanism Drawing for proper placement of switch on the structure.
3. Check mounting surface for unevenness. Use shims under the clip angles to level, if necessary.
4. Bolt clip angles solidly to the structure.

Single Pole Adjustments

Be sure each single pole is properly adjusted before connecting the controls and operators.

1. With the switch bolted solidly to the structure, check to make sure that the single pole opening is as specified in the single pole assembly drawing.
2. Check blades to be sure they contact squarely and smoothly. If they do not, refer to **Preferred Switch Assembly Method:** section.
3. After connecting the bus, all adjustments should be rechecked.

Arcing Horn Adjustment

If optional arching horns are supplied and adjustment is required, proceed as follows:

1. With switch in closed position, adjust horns to make contact (**Figure 6**).
2. Open switch slowly. Horns should make sliding contact along their entire length when the switch is closing or opening.
3. Adjustment of the arcing horn can be done by grasping it firmly and bending until the action described above is achieved.

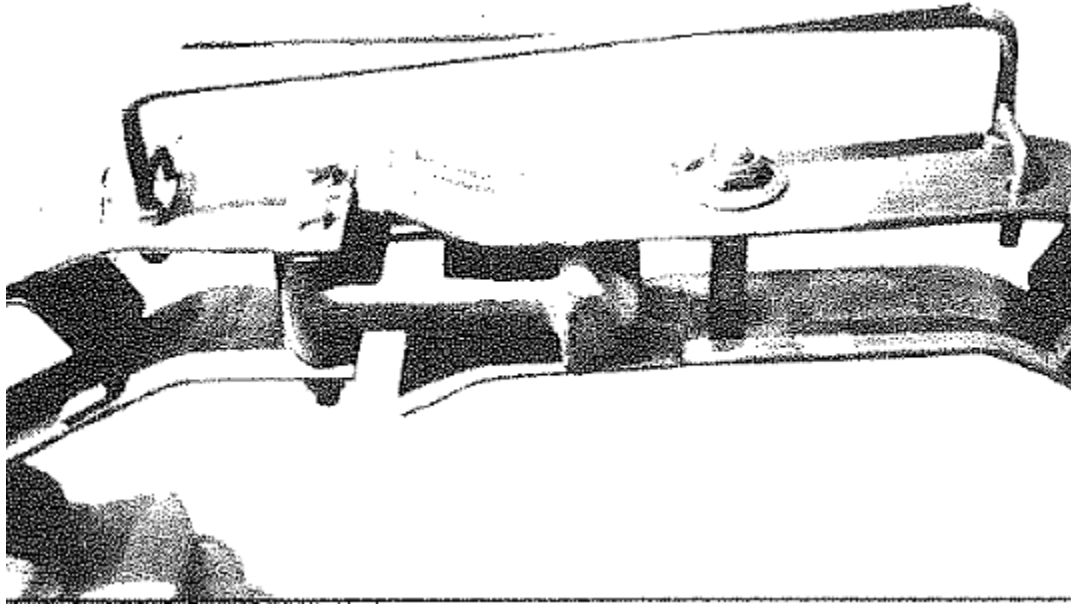

Figure 6: Optional Arcing Horn in Closed Position

Operating Mechanism

1. Lay out all parts and check each one against the bill of materials on the Operating Mechanism Drawing (Op-Mech).
2. Use the Op-Mech Drawing to install mounting brackets, bearings, bushings, pipe clevises, manual operating device, Adjustable Arm, and other components - **Figure 7** and **Figure 8**.

▲ CAUTION

The Pipe Collar must support the entire weight of the Vertical Operating Pipe. Do not allow the manual operating housing to bear any of the Vertical Pipe weight.

Installation & Adjustment Procedures

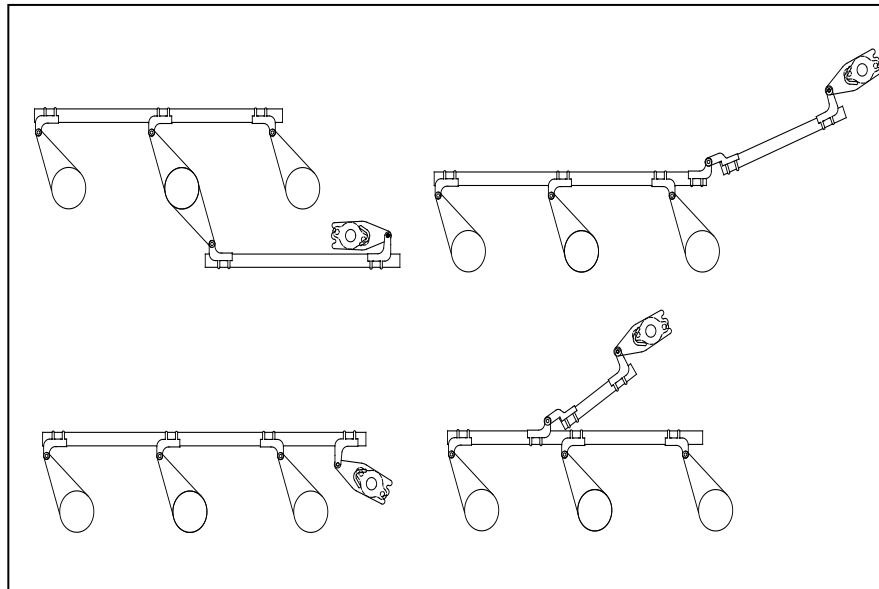

Figure 7: Typical Operating Pipe Arrangement

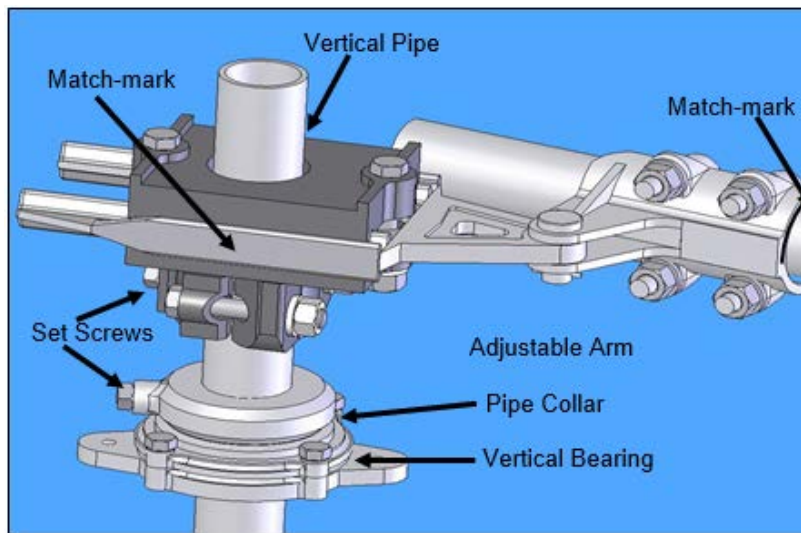

Figure 8: Typical Operating Arrangement

3. Tighten all setscrews to securely grip the pipe. **Do not drive any screws through the pipe wall at this time.**

Installation & Adjustment Procedures

4. If furnished with a Counterweight, refer to the Grounding switch Unit Assembly and **Figure 9** for installation details.

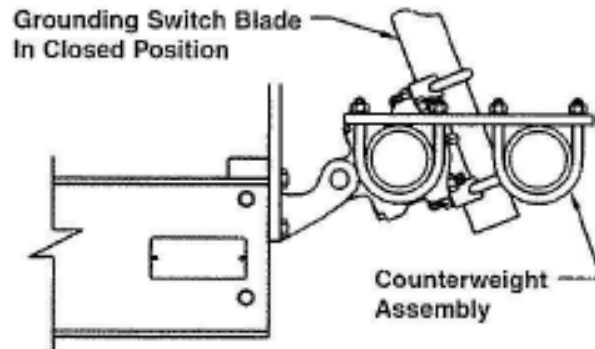

Figure 9: Counterweight Assembled

5. After mounting all operating mechanism components, use any convenient means to match-mark all clevis connections, Adjustable Arm, and manual operator attachments to check for slippage during trial operations.

Installation & Adjustment Procedures

Operating Mechanism Adjustment (Three Phase Installation)

1. Position all Grounding Switch poles closed and all Disconnect Switch poles open.
2. The Adjustable Arm setting on the Op-Mech Drawing is a calculated dimension. Adjust as required for exact setting.
3. The Adjustable Arm radius is **too short** if the Grounding Switch does not open fully (Blade in horizontal position). To correct:
 - Check for slippage
 - Return the switch to the closed position.
 - Operate the switch toward the open position to remove pressure on the linkage.
 - Loosen Adjustable Arm and Clevis Bolts - **Figure 10**.

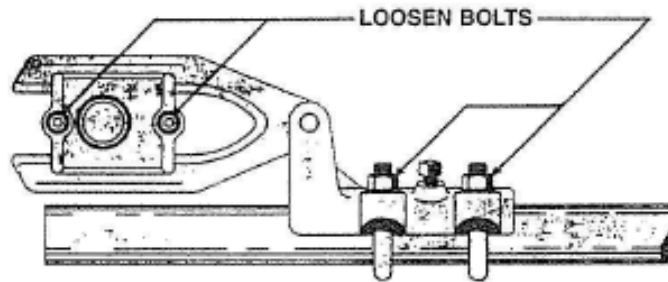

Figure 10: Top View of Adjustable Arm Assembly

- Lengthen the Adjustable Arm radius approximately $\frac{1}{4}$ ". Shorten the pipe to allow the Clevis to reposition itself the same distance.
 - Re-tighten the Adjustable Arm and Clevis Clamping Bolts.
 - Test Operate. Re-adjust as necessary.
4. The Adjustable Arm radius is **too long** if the Grounding Switch reaches the fully open position (Blade in horizontal position) before the switch operator reaches the open position. To correct:
 - Check for slippage
 - Return the switch to the closed position.
 - Operate the switch toward the open position to remove pressure on the linkage.
 - Loosen Adjustable Arm and Clevis Bolts - **Figure 10**.
 - Shorten the Adjustable Arm radius approximately $\frac{1}{4}$ ". Lengthen the pipe to allow the Clevis to reposition itself the same distance.

Installation & Adjustment Procedures

- Re-tighten the Adjustable Arm and Clevis Clamping Bolts.
 - Test Operate. Re-adjust as necessary.
5. All poles of the fully adjusted switch should close completely and operate together. Slight adjustment of the Hinge Assembly Clamping Bolts may be necessary to coordinate all three poles. Rapid operation of the manual handle may be necessary to achieve full closing of all three poles.
 6. No adjustment of the Grounding Switch Blade closest to the Operating Arm is necessary.
 7. The Grounding Switch Blade on the remaining two poles will require “lead” (Blade movement in advance of the Blade on the pole closest to the Operating Arm):
 - With the Grounding Switch in the open position, match-mark the Hinge Clamp and pipe.
 - Adjust “lead” by elevating the Blade slightly - **Figure 11**.

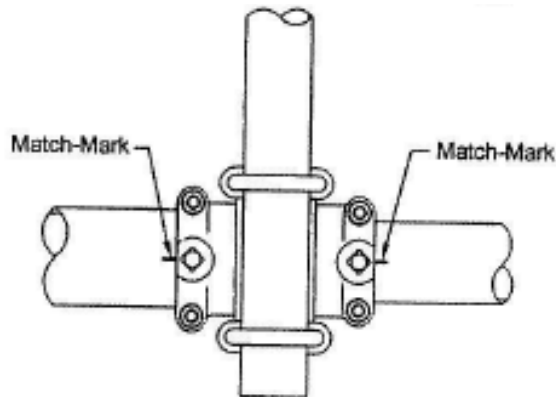

Figure 11: Match-Marked Hinge Clamp and Pipe

- Be sure the Blade Tip rests against the Blade Stop when the Blade is in the closed position.
 - Test Operate. Re-adjust as necessary.
8. When the switch is fully adjusted:
 - Pre-drill pipe for setscrews with the Threaded Drill Guides supplied and a ¼” drill.
 - Securely tighten all bolts.
 - Tighten setscrews until pipe wall is pierced - **Figure 12**

⚠ CAUTION Penetrate the aluminum pipe only with setscrews. Forcing setscrews into the steel pipe can result in casting breakage.

Installation & Adjustment Procedures

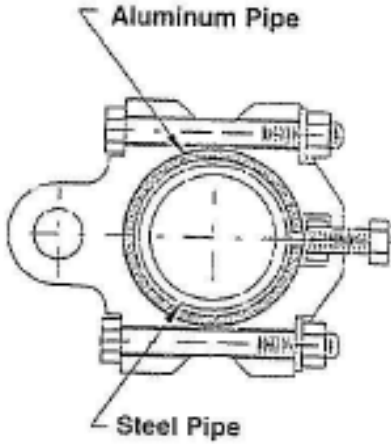

Figure 12: Piercing Pipe Wall

Installation & Adjustment Procedures

Final Switch Adjustments (Tuning)

1. The operating mechanism is intended to fully open and fully close the disconnect switch by rotating the vertical operating pipe about 180° using an operator (manual or electrical). The interphase pipe controls the individual operation of each switch pole, using a push/pull control. The reach rod translates the motion of the vertical operating pipe to the interphase linkage. The adjustable arm controls the total amount of switch operation available.

HINT: For easiest adjustment start with the reach rod connected to the drive phase and the interphase pipe disconnected from the other two phases. Once the drive phase is properly adjusted, connect the interphase pipe and continue tuning the other two phases, one at a time.

2. Switch Operating Devices:

1.3 Worm gear operator (HOGO – High Output Geared Operator) (Optional)

2.1.1. The weight of the vertical operating pipe should be supported by pipe collar (Error! Reference source not found.) by maintaining the 1/4" - 3/8" gap (Figure 13).

2.1.2. When the switch is properly adjusted the operator handle should hang freely in both the open and closed positions to permit the use of a customer supplied padlock. Refer to Figure 13.

CAUTION Be aware that there is an adjustable stop on the operator. **Do not over operate as damage will occur to the operator.**

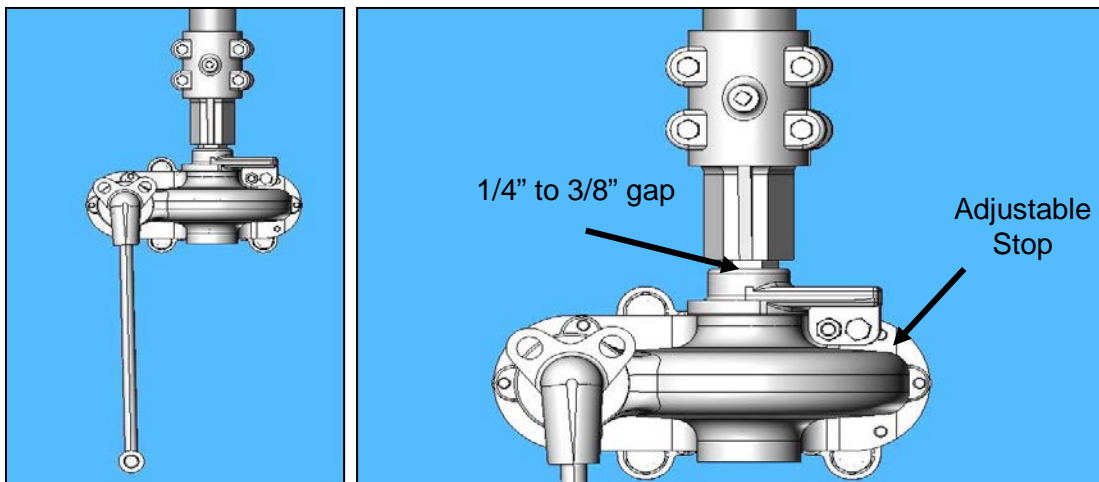

Figure 13: Type HOGO (High Output Geared Operator) Front View

Installation & Adjustment Procedures

- 3.1. Worm gear operator (SEGO – Safety Enhanced Gear Operator) (Optional)
 - 3.1.1. The weight of the vertical operating pipe should be supported by pipe collar by maintaining the 1/4"-3/8" gap.
 - 3.1.2. When the switch is properly adjusted the operator handle should hang freely in both the open and closed positions to permit the use of the customer supplied padlock.

⚠ CAUTION Be aware that there is an adjustable stop on the operator. Do not over operate as damage will occur to the operator.

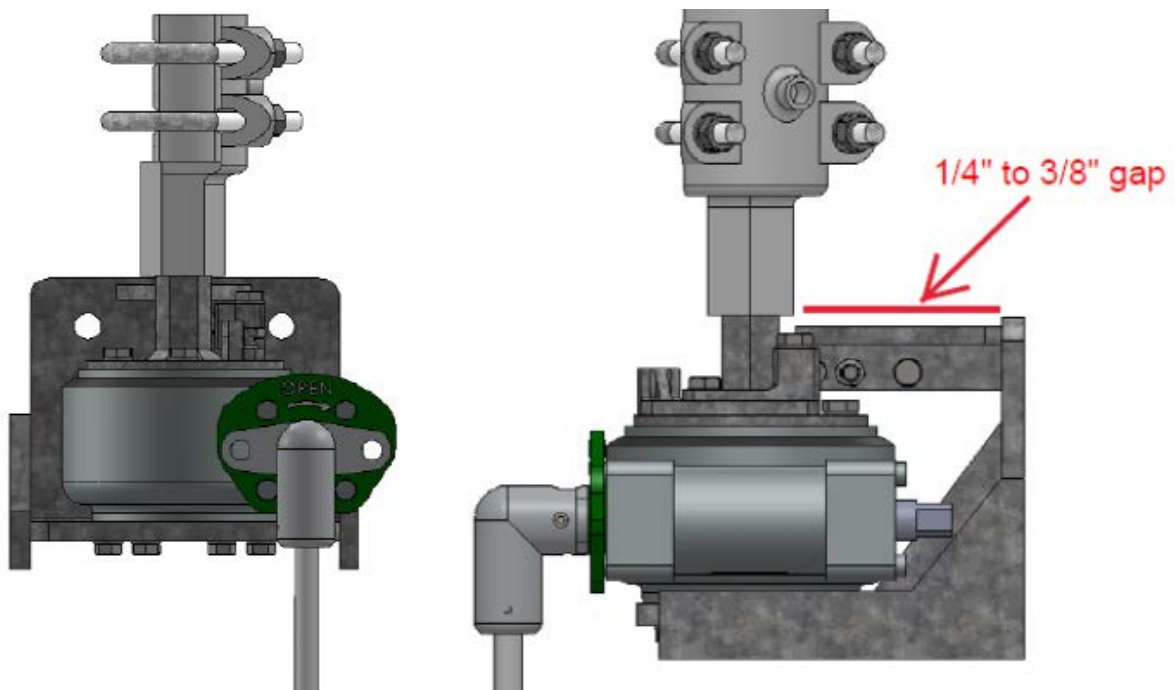

Figure 14: Type SEGO (Safety Enhanced Gear Operator)

2.3 Swing handle operator

- 2.2.1. When the switch is properly adjusted the handle should hang vertically and free in both the open and closed positions to permit the use of a customer supplied padlock.

3.3 Electrical motor operator

- 2.3.1. Please refer to motor operator instruction manual for proper installation and setup.
- 2.3.2. Use manual operation while completing switch setup.
- 2.3.3. **Do not** electrically operate until all switch adjustments are complete. **ALWAYS** operate the motor operator decoupled first to ensure proper setup.

General Instructions for Threaded Clevises

General Instructions for Threaded Clevises

When threaded clevises are specified, one is generally attached to the adjustable arm, and two more to the center phase switch arm (refer to the plan view of the operating mechanism drawing and the illustration below).

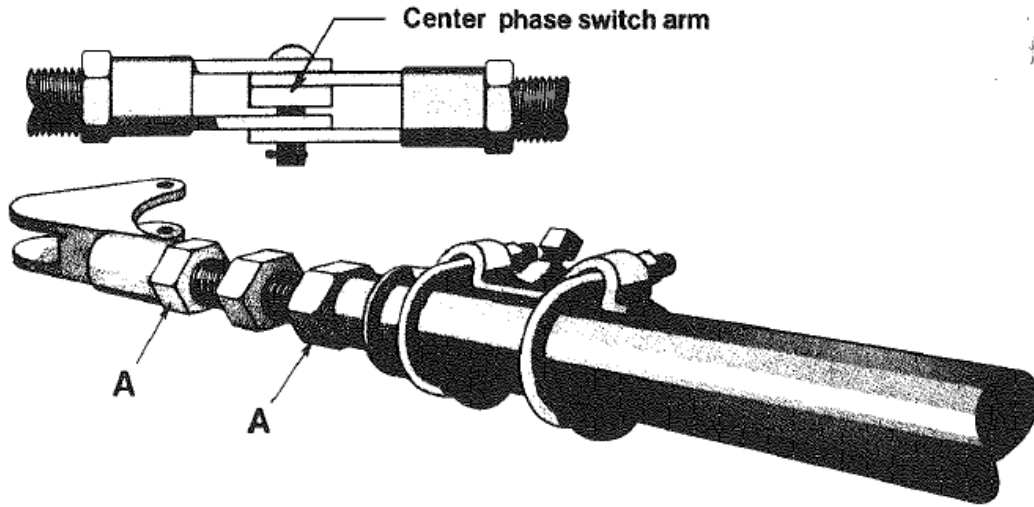

Operating mechanism adjustments consist mainly of incremental lengthenings and/or shortenings of the pipe that connect the switch arms together. To make these adjustments, simply loosen both jam nuts "A" and screw the stud in or out as required. Be sure to retighten both jam nuts securely.

▲ CAUTION ▲ DANGER Do not screw the stud out of the clevises. This could cause the pipe to fall, resulting in serious injury to personnel below.

Be sure the initial setting is correct, and do not adjust beyond the maximum allowable dimension. If adjustment beyond the maximum allowable dimension is needed loosen the U-bolts on the outboard phase clevis and reposition the pipe toward the center phase.

Initial dimension for $\frac{3}{4}$ " stud is $\frac{11}{16}$ "; 1" stud is $\frac{1}{2}$ ".

Maximum allowable for $\frac{3}{4}$ " stud is $1\text{-}\frac{3}{16}$ ".
Maximum allowable for 1" stud is 1".

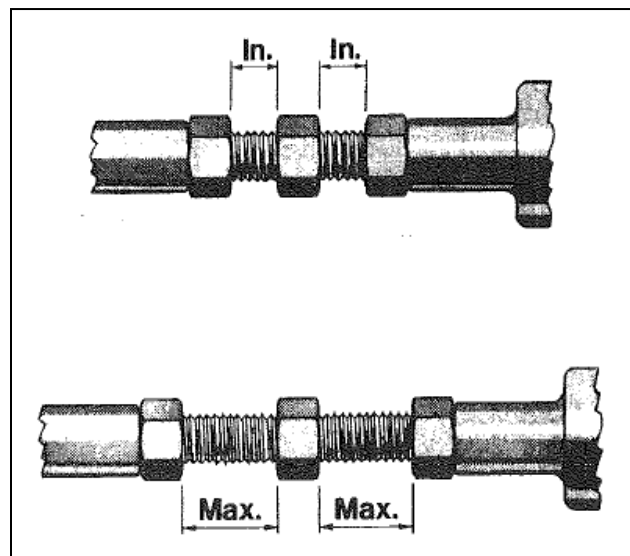

Recommended Inspection Maintenance

Failure to properly maintain the equipment can result in severe personal injury and product damage. The following maintenance procedures must be performed regularly and do not represent an exhaustive survey of all maintenance steps necessary to ensure safe operation of the equipment. Particular problems that may arise should be referred to the local Southern States, LLC, representative.

1. The switch should be cleaned periodically to remove contaminant particles that have been on the switch. Cleaning after installation is recommended to remove dirt or other contaminants that have been deposited on the switch during shipment or storage.
2. Check for loose bolts and nuts; tighten as needed.
3. Examine the contact surfaces for wear or pitting.
 - a. Slightly damaged surfaces of the male blade plus can be smoothed with a burnishing tool or crocus cloth. Do not burnish or sand female blades.
 - b. If severe damage has occurred, replace the damaged part with Southern States replacement parts.
 - c. Examine the switch blade contact alignment and realign if necessary.
4. Check all galvanized surfaces for chips. If chipping has occurred, use a zinc rich paint or cold galvanizing spray for touchup.
5. Verify Operating Mechanism establishes full open and closed positions of the switch live parts.
6. Before energizing switch, be sure to follow ANSI/IEEE C37.35 "Guide for the Application, Installation, Operation and Maintenance of High-Voltage Air Disconnecting and Load Interrupter Switches". Pay particular attention to section 5.11 "Inspection".



The Quality Name in High Voltage Switching

30 Georgia Avenue
Hampton, Georgia 30228
Phone: 770-946-4562
Fax: 770-946-8106
E-mail: support@southernstatesllc.com
<http://www.southernstatesllc.com>

©2017 Southern States, LLC
IB-132-CBL-T 72.5- R4 060217 Printed U.S.A.