

Supersedes Bulletin 500 dated January, 1977

APPLICATION

Typically, motor mechanisms are used to provide remote control power operation of air break switches in large switchyards. As switchyards increase in size it becomes impractical to manually perform the many switching operations, and motor operators allow any number of switching schemes to be performed remotely from one central control. Motor operators also make unattended substations possible; their various switching requirements can be done by supervisory controls or relay schemes.

Another major usage of motor mechanisms is operating high speed grounding switches and air break switches in conjunction with circuit breakers to isolate faults, such as malfunctioning transformers or storm-damaged lines, to limit outages to the faulted section. In addition, motor mechanisms operating air break switches are used with circuit breakers in a variety of transfer schemes to locate and isolate dead faults in a system.

The Southern States VM-1 Motor Mechanisms will provide dependable power operation of air break switches of virtually any manufacturer, and will coordinate any of the above systems as well as other, specialized applications. The VM-1 is available in a wide range of motor voltages, output torques, and operating times, and it will reliably operate any switch within its specified range.

All VM-1's have provisions for station power control and manual operation. All VM-1's are equipped with a decoupler to disengage the mechanism from the line switch for testing and other purposes. The VM-1 can use either transformers or batteries for a power supply.

The VM-1 is mounted to a structure and coupled to the vertical pipe of the switch operating mechanism. The degree of mechanism rotation is normally specified upon ordering; however, it may be readily changed in the field from a minimum of 30 degrees to a maximum of 330 degrees. The full rated torque of the VM-1 is available throughout its operation.

Southern States, Inc.

Type VM-1

MOTOR MECHANISM

Motor Operator for all Group Operated Air Switches

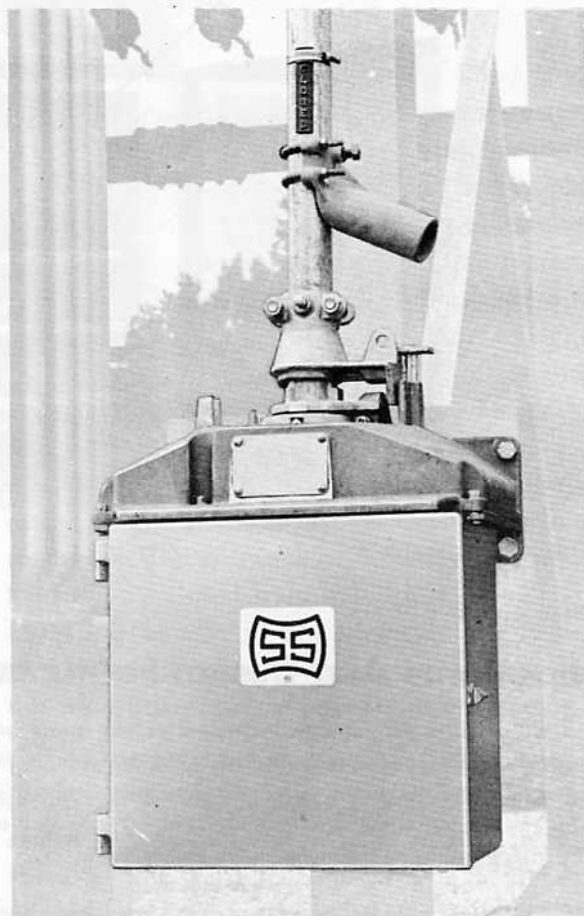

FIGURE 1

Adjustable position lock makes the VM-1 adaptable to virtually any switch from any manufacturer. See Figure 8 on page 5.



Southern
States, Inc.

The Quality Name In High Voltage Products

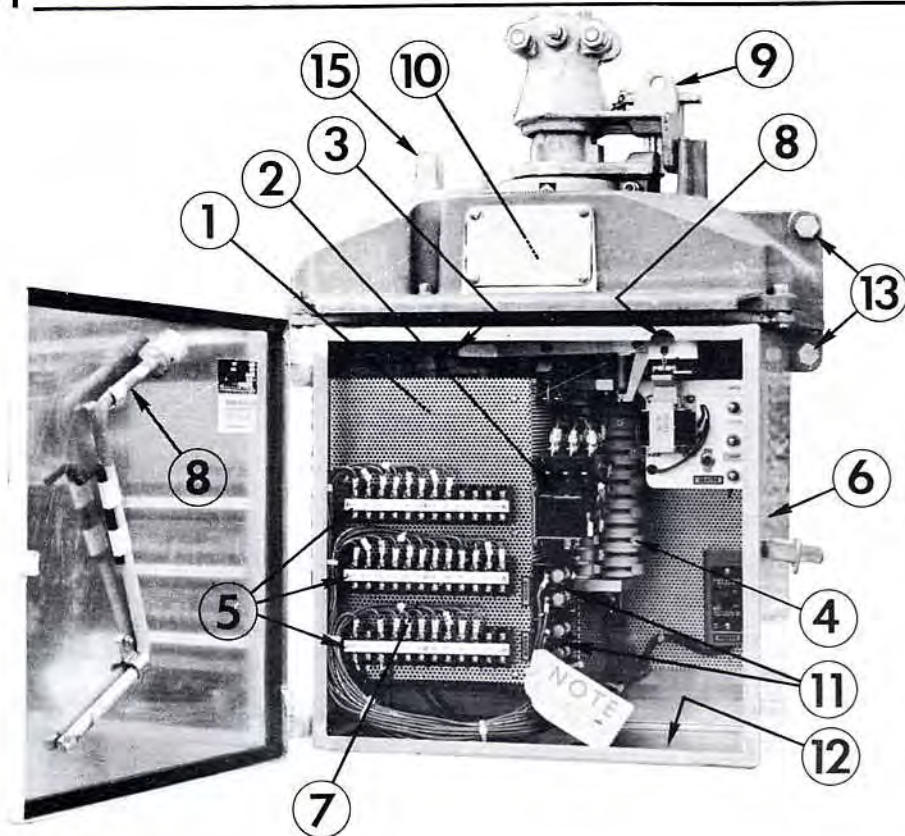

FIGURE 2

Components And Design Features

The VM-1 Motor Mechanism incorporates the most advanced technological features to provide dependable, fool-proof operation and maximum safety to personnel and equipment. In the years since its introduction, it has gained unusually high preference throughout the industry.

① MOTOR: All VM-1's are equipped with a high torque motor that yields its full rated torque at the NEMA minimum voltages. The motors are available in the six standard NEMA voltages: 24, 48, 125, and 250 DC; 115 and 230 AC.

The motor bearings are lifetime lubricated and sealed; the VM-1 motor requires no maintenance. In addition, it is fully protected from damage by a thermal overload relay.

② MOTOR CONTROLLER: A three position push button station (OPEN, CLOSE, STOP) is standard equipment on all VM-1's. This feature can be omitted if desired.

The motor controller is a magnetic reversing, across-the-line type. Magnetic contactors maintain the power flow until the operating cycle is completed (unless countermanded by the STOP button). The operating coils of each rated voltage will function in a normal manner at the NEMA minimum voltages. The contactors are both mechanically and

electrically interlocked, eliminating any possibility of energizing one coil when the other coil is energized.

Rigorous testing has shown that the motor controller will perform reliably, even under locked rotor conditions.

③ BRAKE: Mechanism overtravel is prevented by a mechanical spring loaded, disc type brake. The VM-1's brake does not require periodic adjustment. When the motor circuit is open, the brake prevents rotation of the motor shaft and the drive train. When the motor circuit is energized, a solenoid releases the brake. When the limit switches (or STOP button) open the motor circuit, the brake solenoid circuit is opened, and the brake stops the output shaft.

It is important to note that the VM-1 *positively locks* the line switch in both the open and the closed position - or any position in between, and will withstand up to 20,000 inch-pounds of torque applied to the vertical pipe. This feature gives an added degree of security and safety not found on other operators and it is especially valuable in preventing "creepage" of the line switch in cases where toggle operating linkages are not used. The positive disc brake of the

in contact with live circuits. These barriers also greatly increase the leakage distance between the terminals. The VM-1 is wired at the factory with all leads connected to the terminal blocks, and the user makes all field connections to clearly marked, completely accessible terminals. Additional terminals will be provided as specified.

⑥ **CABINET:** The cabinet of the VM-1 is all aluminum. It is completely maintenance-free and weather-proof. The top section is a cast aluminum gearbox housing with a sheet aluminum access plate. The lower section is welded 1/8" sheet aluminum with a 180 degree opening door of the same material. Both upper and lower sections of the cabinet are vented for condensation control. Aluminum was chosen for its appearance, strength, rust-proof qualities, and light weight. The standard VM-1 weighs less than 150 pounds.

The cabinet door swings on "lift-off" hinges and is easily removed when it is open. The door is gasketed to prevent the entrance of moisture or run-off and is held tightly closed by a pull-down latch. The manual operating handle is stored inside the cabinet, and only one padlock is necessary to secure the mechanism from unauthorized operation or entrance.

⑦ **HEATER:** A 100-watt heater prevents condensation inside the cabinet. It may be easily wired for either 115 or 220 volts AC by merely swapping two wires at the terminal block. The heater circuit is double fused for complete protection, and control is by a conveniently located on/off switch, or an optional thermostat.

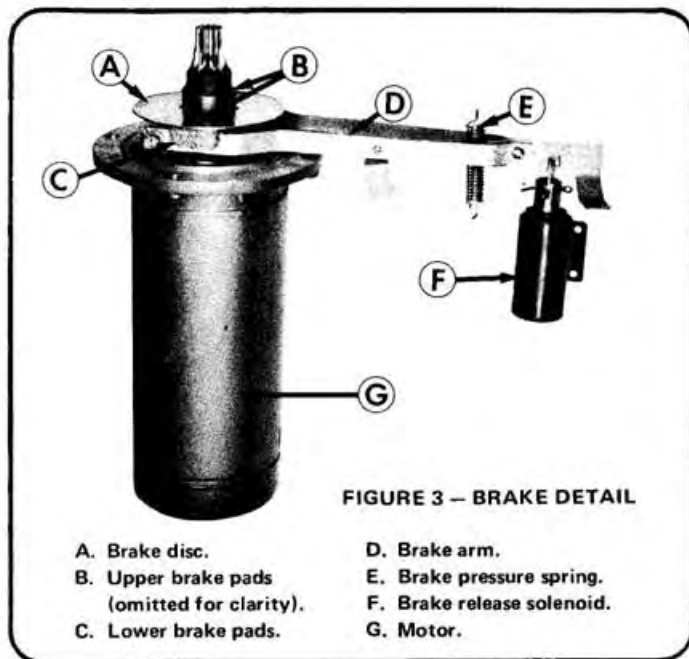

FIGURE 3 - BRAKE DETAIL

- | | |
|--|----------------------------|
| A. Brake disc. | D. Brake arm. |
| B. Upper brake pads (omitted for clarity). | E. Brake pressure spring. |
| C. Lower brake pads. | F. Brake release solenoid. |
| | G. Motor. |

VM-1 is in contrast to the non-positive, "dynamic" braking systems found on some other motor operators.

④ **AUXILIARY SWITCH:** The standard auxiliary switch has 10 poles available for the customers use, with up to 10 extra available as an option.

The cams of the auxiliary switch are *readily accessible* and infinitely adjustable for opening points, closing points, and dwell angles. These settings are easily made in the field by loosening one screw and sliding the cam around the cam wheel. The cam follower and cam action are visible without having to dismantle the switch. This means that the make and break points can be determined in the field without using a test lamp. Current flow is straight through the switch, and the circuits are easily traced.

The dielectric strength of the auxiliary switch exceeds U. L. requirements for 600 volt equipment. In addition, insulating barriers between adjacent circuits create very long leakage paths. This greatly reduces the possibility of leakage currents causing false indications or malfunctions of devices wired to the auxiliary switch.

The high continuous current ratings and the high interrupting capacity of the VM-1's auxiliary switch will, in some cases, make expensive relays on auxiliary circuits unnecessary.

⑤ **TERMINAL BLOCKS:** The 600 volt, molded phenolic terminal blocks are located at the front of the cabinet for easy accessibility. A safety feature is a high barrier between each terminal which reduces the possibility of personnel inadvertently coming

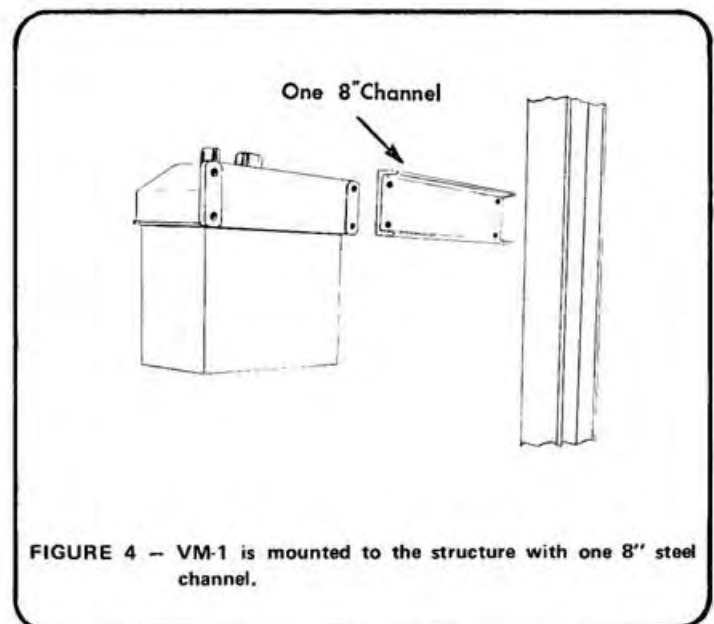

FIGURE 4 - VM-1 is mounted to the structure with one 8" steel channel.

Type VM - 1

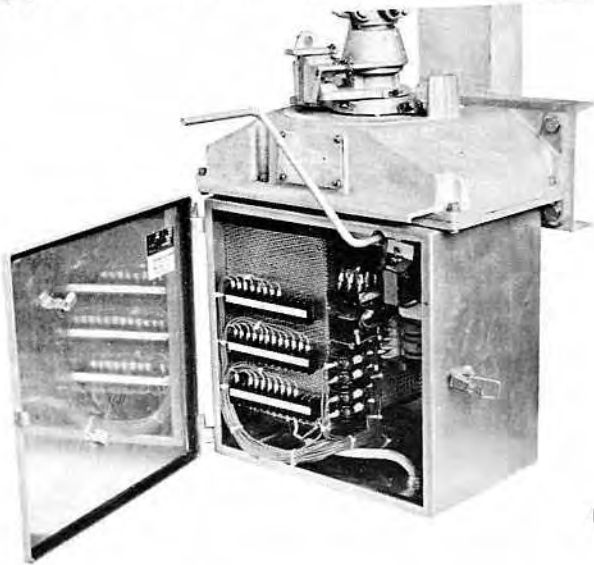
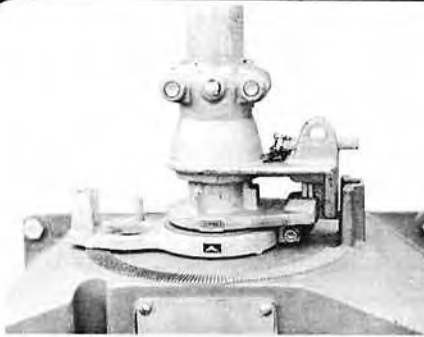

FIGURE 5

⑧ **MANUAL OPERATION:** Two interlocks insure absolute safety and convenience to personnel during manual operations. The manual operating handle cannot be engaged without de-energizing the motor circuit. Depressing one interlock lever removes the

guard from the manual operating shaft, releases the brake, and opens the motor circuit. The gear train operates smoothly with a minimum of effort through a reduction ratio of 30 to 1. The manual operating handle is stored *inside* the cabinet which provides secure storage without an extra padlock.



Mechanism coupled; (mechanism closed - line switch closed)

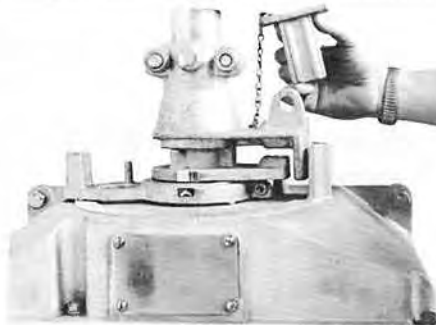

Decoupler operation; (removal of decoupler key)

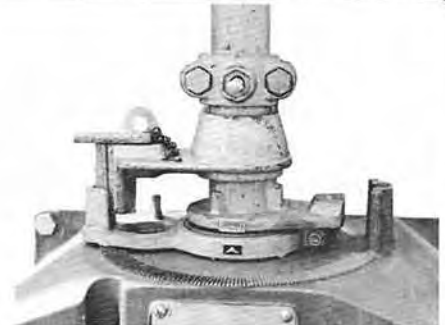

Line switch locked open; mechanism closed.

FIGURE 6

⑨ **DECOUPLER:** The decoupler on the VM-1 is simple and easy-to-operate, and is standard equipment on all VM-1 Motor Mechanisms. The rugged construction of the decoupler guarantees a lifetime of trouble-free performance, and the following designed-in features provide maximum flexibility of operation:

- Precise, positive coupling. No mistakes.
- Easily visible mechanism position indicator on the decoupler.

- Vertical pipe connection that allows misalignment as well as thermal expansion and contraction of the vertical pipe.
- The VM-1 may be test operated with the line switch *locked* in both open and closed positions.
- All captive parts; no loose keys or pins to mislay.
- The decoupler is fool-proof; *it cannot be recoupled in the wrong position.*

Type VM-1

⑩ **GEAR TRAIN:** All ratings of the VM-1 use the same basic gear housing, but with different ratios for the various ratings. The gear train uses highly efficient, heavy duty spur-gears. The gear tooth profiles have been optimized for maximum strength and smooth operation.

Sealed, lifetime-lubricated needle bearings support the gear shafts. These bearings require no maintenance. The gear train will withstand the full over-voltage stalled torque of the motor without deformation or damage.

⑪ **FUSES:** The motor and the heater are on separate circuits, and both are double fused to prevent damage from inrush currents on either side of the circuit. These fuses are located in the front of the cabinet for accessibility. As an option, the VM-1 may be equipped with circuit breakers rather than fuses.

⑫ **CONDUIT ENTRANCE:** Conduit entrance is through the bottom of the cabinet. The conduit entrance is a large aluminum plate which is easily removed for field drilling.

⑬ **MOUNTING:** The mounting arrangement of the VM-1 is both economical and strong. The usual

member is one 8" channel attached to the structure. The light weight of the VM-1 makes handling easy, and the mounting arrangement cuts installation time to a minimum.



FIGURE 7

⑭ **SWING HANDLE SOCKET:** Standard equipment on every VM-1 is a swing handle socket which mounts on the vertical operating pipe. This socket will accommodate any handle up to 2" OD and makes it possible to manually operate the line switch *independently* of the mechanism. An insulated swing handle is available as an optional feature.

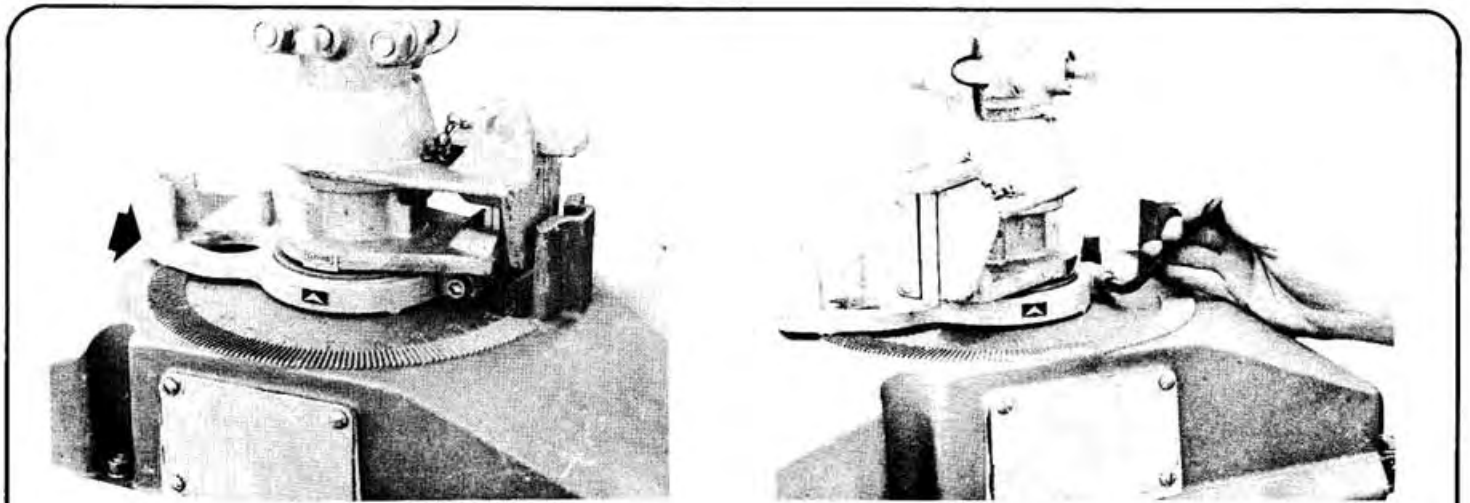

FIGURE 8

⑮ **ADJUSTABLE ROTATION STOPS:** The VM-1 will power virtually any switch from any manufacturer; it can be easily field-adjusted to adapt even to non-standard rotation switches. The open and closed position stop/locks can be changed from 30°

to 330° in 1-1/2 degree increments merely by loosening one screw with an Allen wrench.

No other motor operator has this convenience and flexibility. The VM-1 can be ordered for stock for later use on any switch on your system.

Type VM-1

MAINTENANCE: Under normal service conditions, the VM-1 requires no maintenance. If conditions are severe, the gear train should have its light coating of

silicone lubricant replenished every five years, or as conditions or individual user's practices dictate.

Optional Features:

The great diversity of system arrangements will occasionally generate special requirements for motor operators. The Southern States VM-1 can be readily adapted to virtually any system by the selection of its many optional features:

ADDITIONAL AUXILIARY SWITCH POLES: For systems requiring additional relays, indicating circuits, and other supervisory controls, you may specify up to 10 additional poles on the auxiliary switch.

EXTENDED CABINETS: Some users mount relays or other equipment inside the cabinets of motor operators. The VM-1 is available with an extra long cabinet to provide space for additional equipment.

INDICATING LIGHTS — OPEN/CLOSED mechanism indicating lights are available.

OPERATION COUNTER: To record the number of mechanism operations, an operation counter may be specified. (Not available on motor mechanism with lagging contacts.)

THERMOSTAT: A heater thermostat is available to maintain a temperature range of 70^o to 80^o F.

CIRCUIT BREAKERS: If desired, circuit breakers may be specified instead of fuses in both the heater and motor circuits.

SWING HANDLE: The VM-1 may be specified with a swing handle of non-conductive material if required.

LAGGING CONTACTS: On some systems it is desirable for the mechanism position to be so indicated *only at the completion of the operation*; lagging contacts on the auxiliary switch should be specified for this requirement.

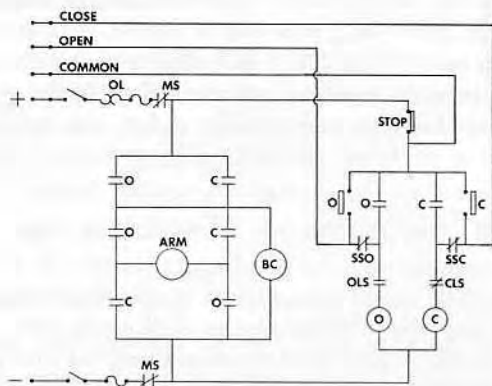

DC - All Voltages

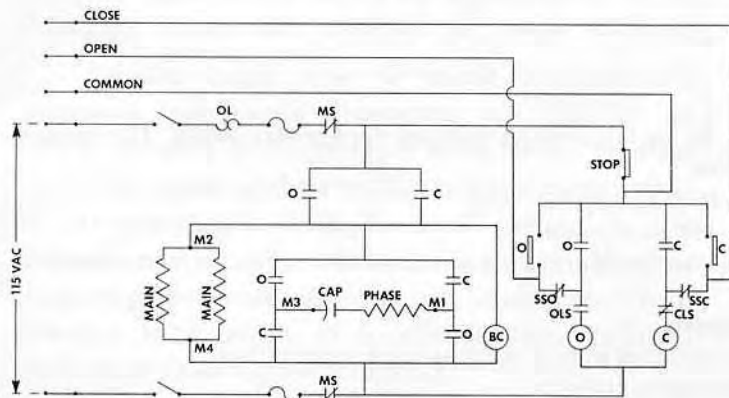

AC - 115V

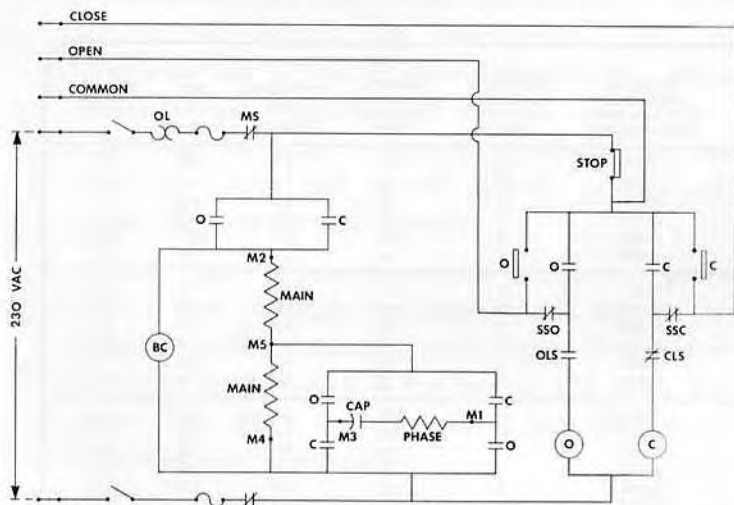

AC - 230 V

- O&C - Open and Close line contactors, mechanically and electrically interlocked.
- OL - Thermal overload relay.
- OLS - Open limit switch.
- CLS - Close limit switch.

- SS - Safety Switches - Open when brake is released. Prevents electrical operation during manual operation and functions as electrical interlock between coils.
- BC - Brake solenoid.
- MS - Motor Safety Switches - Open when manual operating handle is engaged.

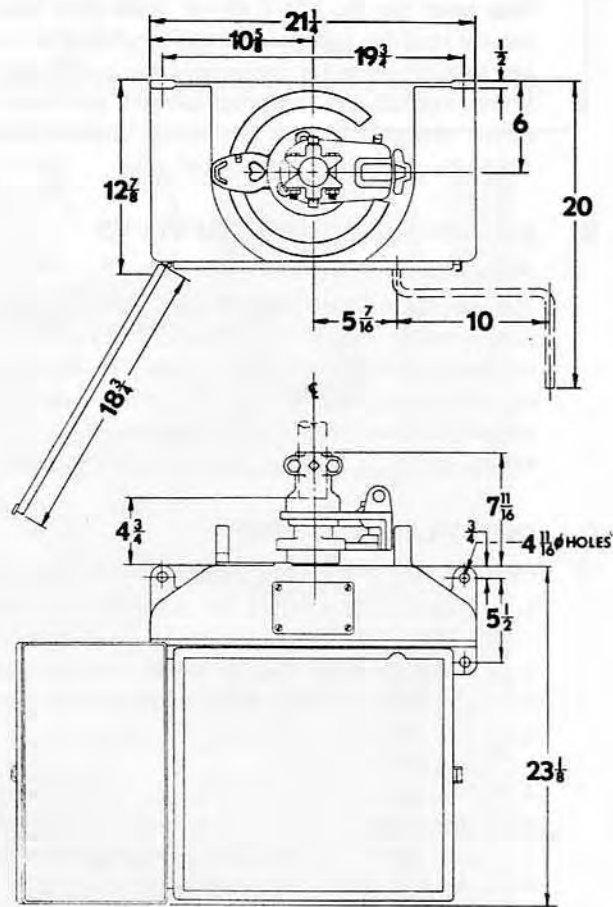

Type VM-1

Specifications

(Parentheses indicate specific information to be supplied by the purchaser.)

A. VM-1 SUPPLIED WITH SOUTHERN STATES AIR BREAK SWITCHES

Base price for the VM-1 Motor Mechanism includes the following: Maintenance-free motor. Motor and control operating voltage shall be: (select one: 115 or 230 V AC; 24, 48, 125, or 250 V DC), push-button station, auxiliary switch having no less than 10 poles for customer's use, a 100-watt heater (select one: 115 or 230 V AC), decoupler, positive action, disc-type brake, weather and dustproof cabinet, provisions for manual operation, position indicators, fused heater and motor circuits, motor thermal overload protection, maintenance-free gear shaft bearings, swing handle socket, and output rotation stops, field-adjustable from 30° – 330°.

B. SEPARATELY SUPPLIED VM-1'S

Please include all information in Item "A" with the following:

The mechanism shall have a rated torque output of not less than (select one: 10,000 or 20,000) inch-pounds, and shall accommodate a (select one: 1-1/2; 2; 2-1/2 IPS) vertical operating pipe. The mechanism shall rotate (select one: clockwise; counter-clockwise) to open through 180 degrees* from fully closed to fully open position. Operating time from fully closed to fully open position shall be (select one: 2; 4; 8; 16) seconds. The mechanism shall be mounted as indicated on the customer's drawing (please enclose drawing).

*Refer to factory for special rotational requirements.

C. OPTIONAL FEATURES

Please specify any of the following features desired:

1. The mechanism shall be supplied with (select one: 16, or 20) available poles on the auxiliary switch. The standard auxiliary switch has 10 poles available for customer's use.
2. The mechanism shall be supplied with an extra length housing. (Specify size)
3. Mechanism Open and Closed position indicator lights shall be supplied.
4. The mechanism shall be supplied with an operation counter. This feature is not available on motor mechanism with lagging contacts.
5. The mechanism shall be supplied with a heater thermostat.
6. The mechanism shall be supplied with circuit breakers in lieu of fuses in the heater and motor circuits.
7. The mechanism auxiliary switch shall be supplied with lagging contacts.
8. An insulated swing handle shall be supplied.

TYPE	CATALOG NUMBER	RATED VOLTAGE (VOLTS)	MINIMUM OPERATING VOLTS	MAXIMUM OPERATING VOLTS	MINIMUM TORQUE AT MIN. VOLTAGE POUND-INCHES	MAXIMUM FULL LOAD CURRENT AMPS	MAXIMUM LOCKED ROTOR CURRENT AMPS	OPERATING TIME SECONDS	NET WEIGHT POUNDS	MANUAL RATIO
VM-1-102	VM-1-10224	24 DC	18 DC	26 DC	10,000	67	200	2-3	140	30:1
VM-1-102	VM-1-10248	48 DC	36 DC	52 DC	10,000	33	100	2-3	140	30:1
VM-1-102	VM-1-102125	125 DC	90 DC	130 DC	10,000	13	40	2-3	140	30:1
VM-1-102	VM-1-102250	250 DC	180 DC	260 DC	10,000	7	20	2-3	140	30:1
VM-1-102	VM-1-102115	115 AC	95 AC	125 AC	10,000	18	108	2-3	140	30:1
VM-1-102	VM-1-102230	230 AC	190 AC	250 AC	10,000	9	54	2-3	140	30:1
VM-1-104	VM-1-10424	24 DC	18 DC	26 DC	10,000	27	82	4-6	140	30:1
VM-1-104	VM-1-10448	48 DC	36 DC	52 DC	10,000	17	50	4-6	140	30:1
VM-1-104	VM-1-104125	125 DC	90 DC	130 DC	10,000	7	20	4-6	140	30:1
VM-1-104	VM-1-104250	250 DC	180 DC	260 DC	10,000	3	10	4-6	140	30:1
VM-1-104	VM-1-104115	115 AC	95 AC	125 AC	10,000	10	56	4-6	140	30:1
VM-1-104	VM-1-104230	230 AC	190 AC	250 AC	10,000	5	25	4-6	140	30:1
VM-1-204	VM-1-20424	24 DC	18 DC	26 DC	20,000	67	200	4-6	140	30:1
VM-1-204	VM-1-20448	48 DC	36 DC	52 DC	20,000	33	100	4-6	140	30:1
VM-1-204	VM-1-204125	125 DC	90 DC	130 DC	20,000	13	40	4-6	140	30:1
VM-1-204	VM-1-204250	250 DC	180 DC	260 DC	20,000	7	20	4-6	140	30:1
VM-1-204	VM-1-204115	115 AC	95 AC	125 AC	20,000	18	108	4-6	140	30:1
VM-1-204	VM-1-204230	230 AC	190 AC	250 AC	20,000	9	54	4-6	140	30:1
VM-1-208	VM-1-20824	24 DC	18 DC	26 DC	20,000	27	82	8-10	140	30:1
VM-1-208	VM-1-20848	48 DC	36 DC	52 DC	20,000	17	50	8-10	140	30:1
VM-1-208	VM-1-208125	125 DC	90 DC	130 DC	20,000	7	20	8-10	140	30:1
VM-1-208	VM-1-208250	250 DC	180 DC	260 DC	20,000	3	10	8-10	140	30:1
VM-1-208	VM-1-208115	115 AC	95 AC	125 AC	20,000	10	56	8-10	140	30:1
VM-1-208	VM-1-208230	230 AC	190 AC	250 AC	20,000	5	25	8-10	140	30:1
VM-1-216	VM-1-21624	24 DC	18 DC	26 DC	20,000	27	82	16-20	150	30:1
VM-1-216	VM-1-21648	48 DC	36 DC	52 DC	20,000	17	50	16-20	150	30:1
VM-1-216	VM-1-216125	125 DC	90 DC	130 DC	20,000	7	20	16-20	150	30:1
VM-1-216	VM-1-216250	250 DC	180 DC	260 DC	20,000	3	10	16-20	150	30:1
VM-1-216	VM-1-216115	115 AC	95 AC	125 AC	20,000	10	56	16-20	150	30:1
VM-1-216	VM-1-216230	230 AC	190 AC	250 AC	20,000	5	25	16-20	150	30:1

