

General Application

Southern States Types CSH and CSH-B Horizontal Circuit Switchers provide an economical, versatile, space saving solution for transformer switching and protection.

The Southern States' circuit switcher design combines SF₆ puffer interruption and optional air break isolation functions into a single compact unit for application on systems with fault currents to 40 kA rms.

The three phase, group operated, interrupting device is typically mounted on a galvanized steel structure provided by Southern States or by others. Pole simultaneity is achieved through the use of shunt trips on opening and through mechanical interphase linkages on closing. A motor mechanism supplies the power to rotate the insulators and to reset both the tripping and the closing springs.

Two versions of the Southern States horizontal circuit switcher are available:

- The Type CSH non-blade model is an end rotating insulator circuit switcher that mounts independent of an air disconnect switch.
- The Type CSH-B blade model is a center rotating insulator circuit switcher that mounts in series with an integral vertical break air disconnect switch.

Both models are offered at voltage ratings of 38 kV through 170 kV and continuous current ratings of 1200, 1600, and 2000 amperes.

Horizontal Circuit Switchers



Types CSH & CSH-B

**38 kV – 170 kV
1200, 1600, 2000 Amperes**

Types CSH and CSH-B Horizontal Circuit Switchers

Key Features

- Interrupter design combines the use of SF₆ gas and the most advanced puffer technology.
- Full strength interrupter insulation:
 - Maintains full BIL insulation across the open interrupter.
 - Permits use of the CSH non-blade model.
 - Increases system reliability.
- Single gap interruption occurs without the use of voltage grading resistors or capacitors.
- Fast interrupting speeds significantly reduce system disturbance, minimizing damage to key system components:
 - 5 cycles at 170 kV and below
- Fault closing and circuit making are fully contained within the interrupter unit:
 - Provides superior equipment protection.
 - Minimizes system disturbances.



Ratings

- **Maximum Voltages**
38, 48.3, 72.5, 123, 145, and 170 kV.
- **SF₆ Interrupter - BIL**
550, and 750 kV
- **CSH-B Disconnect Blade - BIL**
200, 250, 350, 550, 650, and 750 kV
- **Continuous Current - Amperes**
1200, 1600, and 2000
- **Primary Bus Fault Interrupting Rating**
20 kA rms
- **Maximum Transformer Limited Fault**
4 kA rms
- **Interrupting Times (60 Hz)**
5 cycles
- **Close and Latch (fault closing, multiple duty)**
108 kA peak
- **3-Second Short Time Current**
40 kA rms

Typical Assembly and Testing

- Each three-phase circuit switcher is factory pre-assembled, adjusted, tested, and timed with its own motor operator.
- After testing, the unit is match-marked and disassembled in preparation for shipment or is shipped assembled on its common subframe.
- Individual phases are shipped assembled on insulators at all kV ratings.

Warranty

- The CSH and CSH-B circuit switchers are covered by Southern States' standard five year warranty.

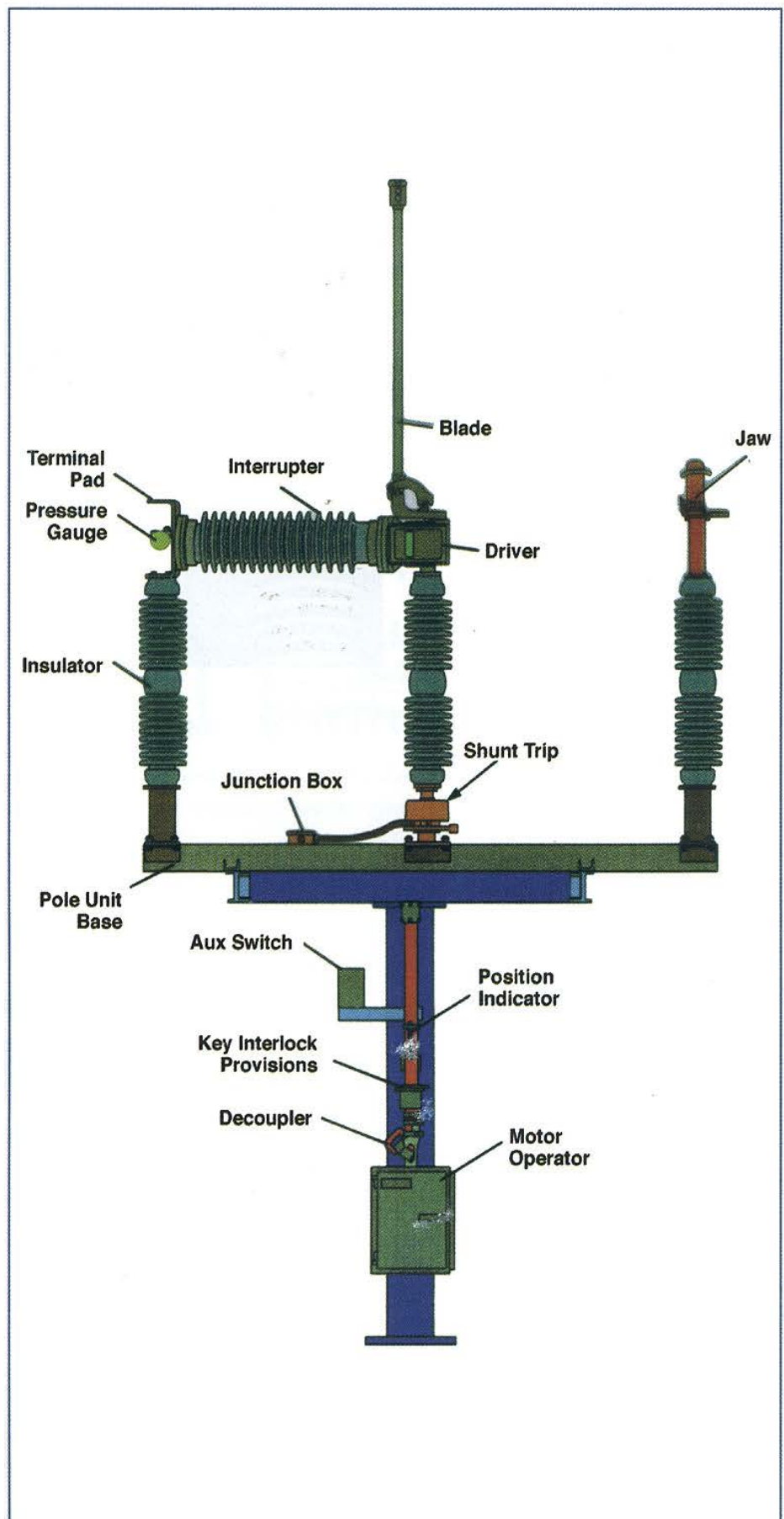

Typical Southern States CSH-B Circuit Switcher – Side View

Interrupter Design Features

■ System Fault Current

Rated for systems up to 40 kA. Switching of magnetizing current occurs without restrikes.

■ SF₆ Interrupting Medium

Units are typically shipped with 5-10 PSIG and are topped off to their rated pressure in the field. It is possible to ship fully pressurized when using composite interrupters.

■ Operating Temperature Range

-40° C to +40° C for 38 kV through 170 kV. (For applications at colder or warmer temperatures contact Southern States.)

■ Interrupter Position Indicator

The position of the interrupter is displayed in the driver window. A colored indicator, directly connected to the moving contact, visually indicates the interrupter's true position.

■ Pressure Gauge

Each phase is equipped with a fill valve, pressure gauge, and over-pressure relief device. The pressure gauge is color-coded and visible from the ground.

■ Full kV BIL

Full BIL across the interrupter permits the switch blade to remain in the closed position indefinitely. The single gap design requires no dividing resistors.

■ Contained Closing

Closing takes place within the interrupter, not on the blade. Erosion of the switch blade contacts and jaw contacts is eliminated, minimizing the need for maintenance. There is no prestrike arcing on the switch jaws to cause system disturbance. No arc products are released into the atmosphere. The low noise level permits installations in residential areas.

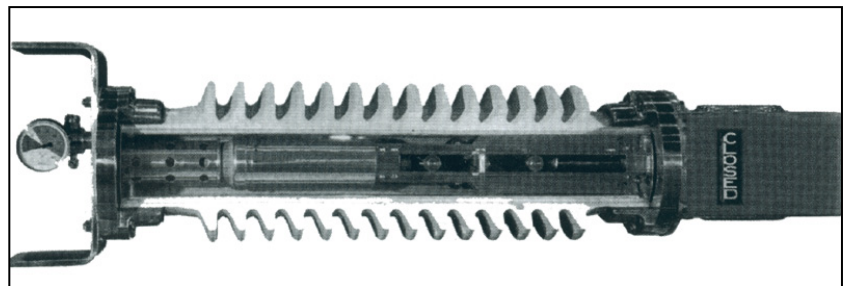
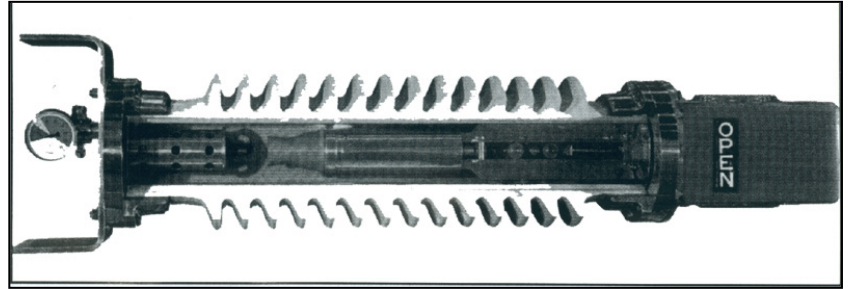
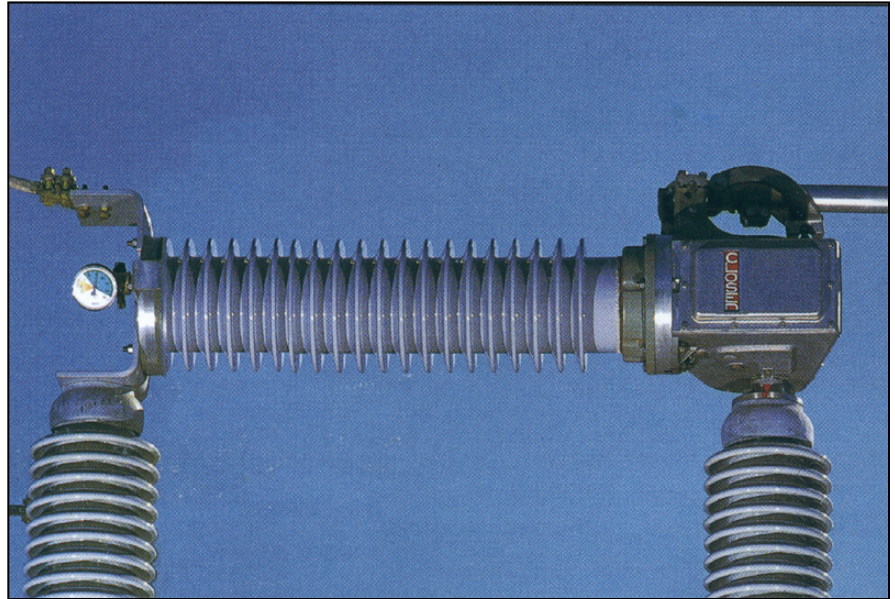

Sequence of Operation

Opening Sequence

Steps 1 through 4 provide a brief illustration of the opening sequence, starting from the fully closed position.

Rotation of the center insulator 12 degrees (by a shunt trip, motor operator, or manual crank) releases the opening springs in the driver mechanism, resulting in high speed opening of the interrupter contacts.

An additional 114 degrees of rotation fully opens the switch blades as shown in Step 4.

Upon reaching the full open blade position, the driver mechanism is reset for a closing sequence.

Charging of the shunt trip equipped units occurs during the last 12 degrees of opening rotation.

Closing Sequence

Rotation of the center insulator to close results in blade travel and charging of the interrupter closing springs in the driver mechanism.

The closing springs are released with the last few degrees of insulator rotation, closing the interrupter and charging the opening springs.

With the CSH-B blade model, the switch blade is closed first, followed by closing of the interrupter, making the circuit in SF₆ gas.

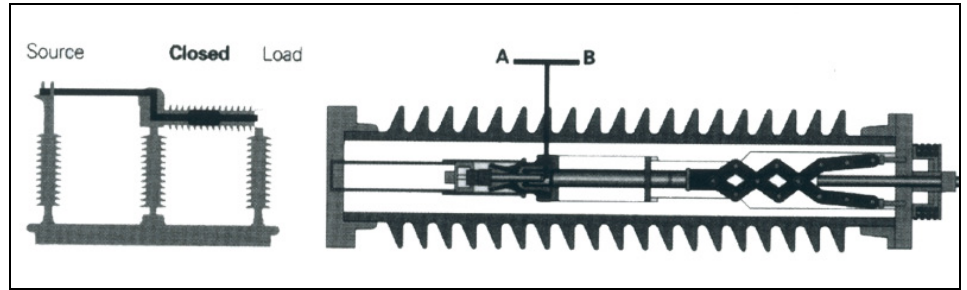

1. Interrupter trips with contacts "A" and "B" in the **closed** position. "A" and "B" remain in contact as "B" travels over "A" and compresses the gas. Gas is ready to flow when the contacts part.

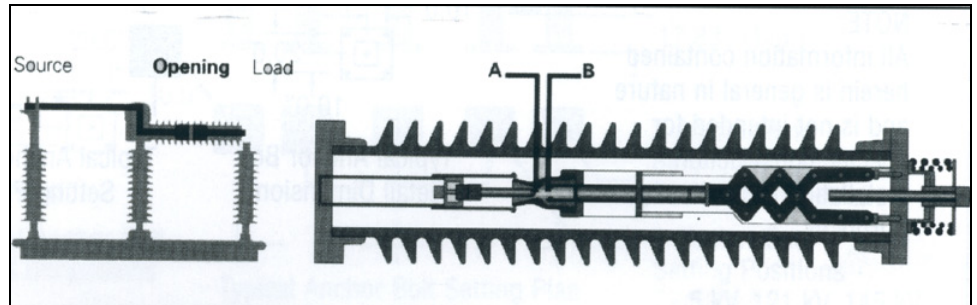

2. Contacts part – arcing begins – gas flows to extinguish the arc.

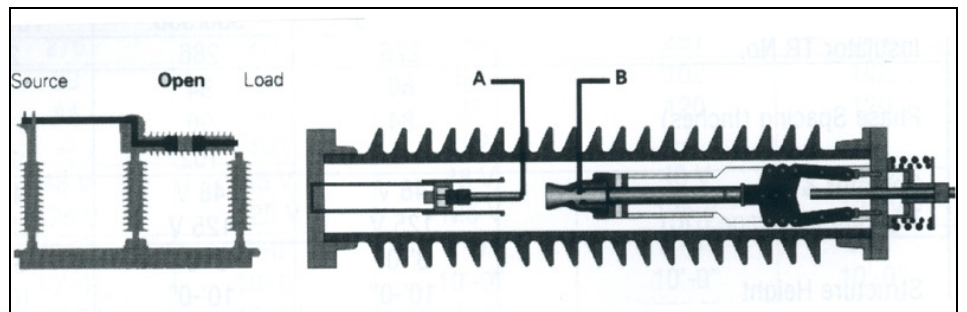

3. Gas divides the arc – interruption complete. Full BIL established. Blade signaled to **open**.

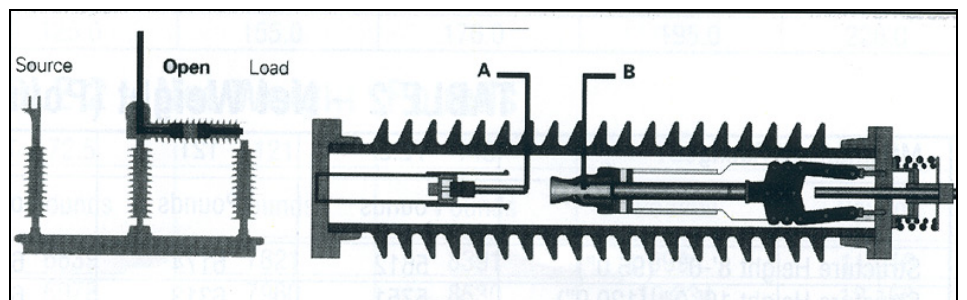

4. Switch blade now in **full open** position.

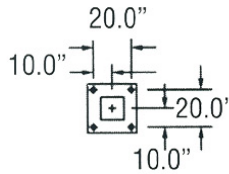
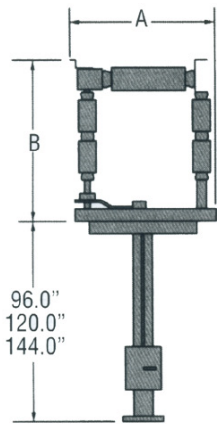

Typical Anchor Bolt Detail Dimensions

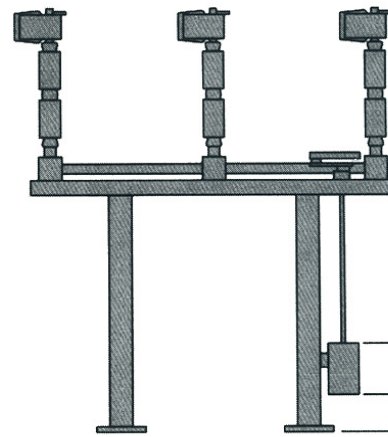

* Contact Southern States for detail.



Typical Anchor Bolt Setting Plan

2 anchor bolt setting positions for 72.5 kV, 123 kV, 145 kV & 170 kV (72.5 kV and below ratings can also be furnished on single column structures.)

NOTE:

All information contained herein is general in nature and is not intended for specific construction, installation, or application purposes. Other structure heights, phase spacings, column spacings, mounting positions, and anchor bolt spacings are available to meet specific installation requirements. Contact Southern States for details.

Type CSH

Table 1 – Dimensions and Ratings

Maximum kV Rating	72.5	123	145	170
Interrupter BIL (kV)	550	550	750	750
Standard Insulator TR No.	276	286	288	291
Standard Phase Spacings (Inches)	60	84	84	102
	84	96	96	120
Operator & Shunt Trip Voltage (VDC)	--	102	102	--
	48	48	48	48
Standard Structure Heights	125	125	125	125
	8'-0"	8'-0"	8'-0"	8'-0"
Dimension "A" (Inches)	10'-0"	10'-0"	10'-0"	10'-0"
	12'-0"	12'-0"	12'-0"	12'-0"
Dimension "B" (Inches)	76.0	76.0	90.3	90.3
	68.9	83.9	92.9	100.9

Table 2 – Net Weight (Pounds)

Maximum kV Rating	72.5	123	145	170
Structure Height 8'-0"	5612	6174	6624	6976
Structure Height 10'-0"	5751	6313	6787	7115
Structure Height 12'-0"	5887	6449	6899	7251

For dimensions, ratings, and weights of 38 kV and 48.3 kV units contact Southern States.

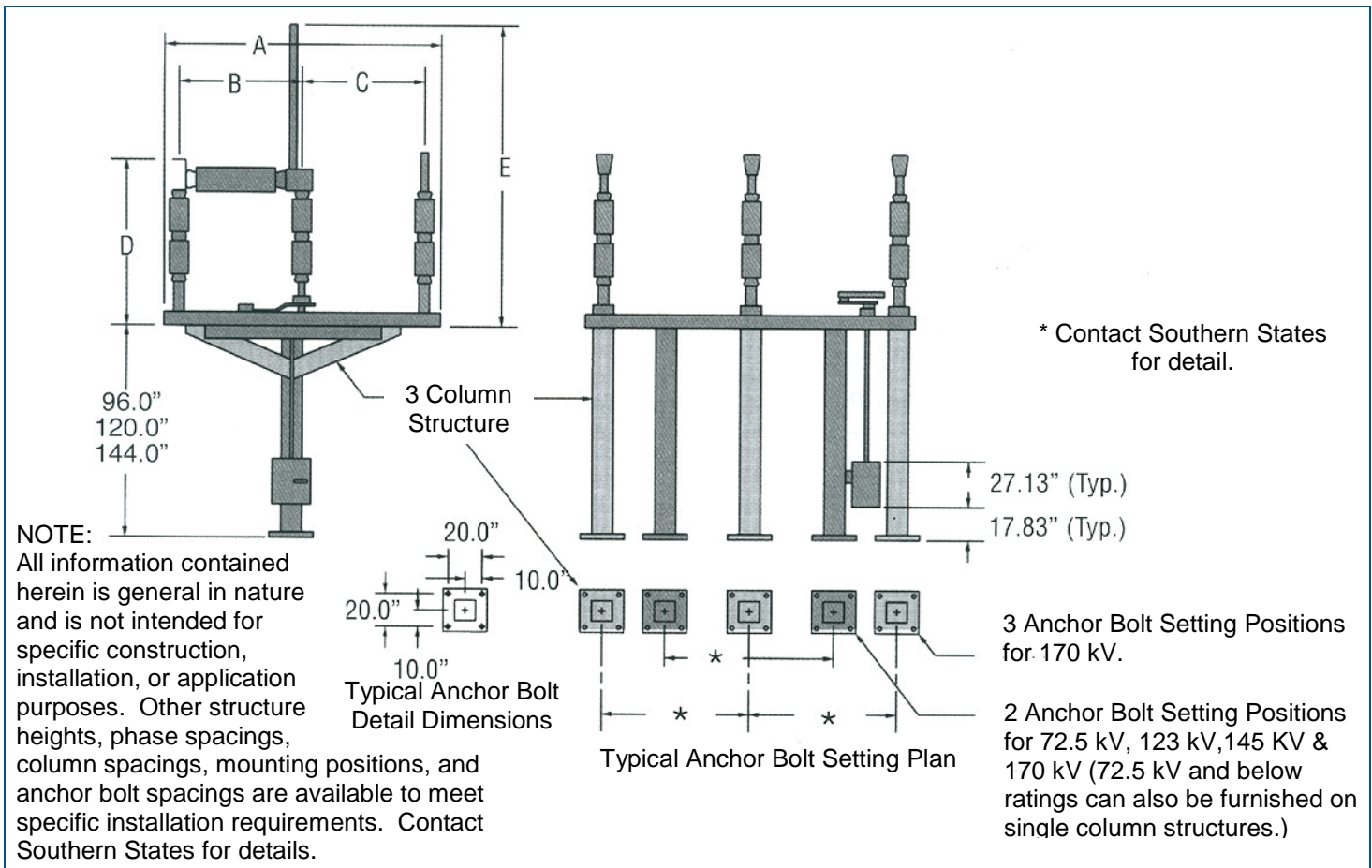

Type CSH-B

Table 1 – Dimensions and Ratings

Maximum kV Rating	72.5	123	145	170
Interrupter/Blade BIL (kV)	550/350	550/550	750/650	750/750
Standard Insulator TR No.	276	286	288	291
Standard Phase Spacings (Inches)	60	84	84	102
	84	96	96	120
Operator & Shunt Trip Voltage (VDC)	--	102	102	--
	48	48	48	48
Standard Structure Heights	125	125	125	125
	8'-0"	8'-0"	8'-0"	8'-0"
Dimension "A" (Inches)	10'-0"	10'-0"	10'-0"	10'-0"
	12'-0"	12'-0"	12'-0"	12'-0"
Dimension "B" (Inches)	112.0	127.0	154.5	166.5
Dimension "C" (Inches)	57.4	57.4	72.5	72.5
Dimension "D" (Inches)	45.0	60.0	72.0	84.0
Dimension "E" (Inches)	68.9	83.9	92.9	100.9
	126.5	156.5	177.5	196.5

Table 2 – Net Weight (Pounds)

Maximum kV Rating	72.5	123	145	170
Structure Height 8'-0"	6839	7821	8391	9994
Structure Height 10'-0"	6978	7960	8530	10234
Structure Height 12'-0"	7114	8096	8666	10474

For dimensions, ratings, and weights of 38 kV and 48.3 kV units contact Southern States.

Circuit Switcher Application Guide

Types CSH and CSH-B Ratings

Application	Duty	Maximum Amperes
Transformer Switching and Protection	Load Breaking ①	1200, 1600, 2000
	Parallel Switching	1200, 1600, 2000
	Primary Bus Fault Interrupting Rating ⑥	25,000 ②③④
	Max Transformer Limited Fault	4,000 ⑤
Line or Cable Switching	Loop Splitting	Southern States <i>LLS</i> ® Recommended
	Load Breaking	
	Line, Cable Dropping	
Capacitor Switching	Shunt Capacitor Bank Switching and Protection	Southern States <i>CapSwitcher</i> ® Recommended
Reactor Switching	Series Reactor Bypass	1200, 1600, 2000
	Shunt Reactor Switching	Southern States <i>RLSwitcher</i> ® Recommended

- ① Southern States circuit switchers can close, carry, and interrupt the magnetizing current of the protected transformer.
- ② The rating shown is applicable for the following duty cycles: O or CO.
- ③ Tripping of Southern States circuit switchers must be coordinated with source-side protective equipment for short-circuit currents in excess of this value.
- ④ Rating is based on transient recovery voltage parameters defined in Table 2 of ANSI standard C37.06-2000 for Southern States circuit switchers rated 38 kV through 72.5 kV and Table 3 for 123 kV through 170 kV.

- ⑤ Southern States circuit switchers are suitable for transformer primary applications where the *inherent* secondary fault current as reflected on the primary side of the transformer, assuming an infinite zero impedance source, does not exceed 4,000 amperes. The *inherent* secondary fault current may be calculated as follows:

$$I = \frac{KVA * 100}{\sqrt{3} * E * Z}$$

where

I = Inherent Secondary Fault Current
KVA = Transformer Self-cooled 3-Phase Rating
E = System Voltage (kV)
Z = Impedance Primary-to-Secondary in Percent

(*Inherent* is defined as secondary-side fault current as reflected through the primary side of the transformer.)

For applications where the *inherent* secondary fault current exceeds the above limits but where the maximum expected fault current, based on transformer impedance plus source impedance, is within these limits, contact Southern States.

- ⑥ Southern States circuit switchers are suitable for use on systems with a maximum source fault of 40 kA.

Technical Data

Operating Current Ratings

Device Description	48 VDC (Amps)	125 VDC (Amps)
Motor Inrush Current	75	33
Motor Running Current	15	7.5
Trip Coil Current	25	25
Reversing Contactor Coil	1	0.5
Anti-Pump Relay Coil	0.2	0.1
Time Delay Relay Coil	0.2	0.1
Motor Fuses Heater Fuses	30 30	15 15

Shunt Trip Unit

Description	Ohms
125 VDC Trip Coil Resistance	15.5
48 VDC Trip Coil Resistance	5.7
Heater Resistance	500

Accessories

Standard

Structures

Southern States circuit switchers are designed for standard support structures provided by Southern States or others. For information on installation on existing support structures, information on other pre-designed structures, or for mobile applications contact Southern States.

Motor Operator

Southern States type CM-4AE motor operator is a torsional output, high torque unit capable of remote and supervisory control.

Shunt Trip

The shunt trip provides high speed tripping for fault protection of power transformers. Each phase has a shunt trip unit consisting of a spring, a latch, and a solenoid within a heated housing. When the system relay senses a fault the solenoid is energized and the spring is unlatched. This gives the insulator a high speed rotational kick, sufficient to break $\frac{3}{4}$ inch ice. The trip coil can be supplied at 48 VDC or 125 VDC, with either voltage coil drawing only 8.33 amperes. The three coils in parallel draw a total of 25 amperes from the time the solenoid is energized until the interrupter clears the fault, minimizing power requirements.

Optional

Bypass Switch

The bypass switch allows the interrupter (and integral disconnect switch blades on type CSH-B model) to be opened and closed for inspection and trip checking of the circuit switcher without opening the high voltage circuit.

External Auxiliary Switch

The external auxiliary switch, used in control circuits and interlocking schemes, is supplied in a separate weatherproof housing and is actuated by the vertical operating pipe.

Ground Switch

The ground switch is a three phase, group operated device furnished with the required momentary rating. Ground switches can be mounted in-line with the circuit switcher bases or perpendicular to the circuit switcher bases.

Interlock

Mechanical, electrical, and key interlocks are available if required for a specific application.

Type CM-AE Motor Operator

General Application

The CM-4AE is a precision built, torsional output, high torque motor operator for use with circuit switchers. It can also be used with disconnect switches and with load and line switchers such as the Southern States types LSH-B, LSH, LLS-II-2000, and LLS-II-3000.

Motor

A permanent magnet motor is available at 48 VDC and 125 VDC. All motors are NEMA rated and are supplied with permanently greased ball bearings. Overload protection is provided by standard dual element fuses which are easily removed.

Brake

Dynamic braking is standard for all CM-4AE motor operators.

Cabinet

The CM-4AE has an all-aluminum, maintenance-free, weatherproof cabinet. Two removable doors allow easy access to the controls, limit switches, motor, wiring, and other internal parts. To secure the motor operator from unauthorized entrance or operation the side door is latched internally and the front door has provisions for padlocking.

Conduit Entrance

The bottom of the cabinet is removable for field drilling to accommodate customer-furnished conduit.

Reduction Gear

The reduction gear is totally enclosed in a cast aluminum housing. It is a spur gear design with a worm gear shaft for manual hand crank operation. Gears and bearings are lifetime lubricated at the factory and require no maintenance.

Manual Operation

All type CM-4AE motor operators are designed to permit manual operation to facilitate installation, maintenance, and inspection. Operation of the circuit switcher manually is possible in the event of a source voltage failure to the motor circuit.

Heater

A 100-watt, thermostatically controlled heater is provided to prevent condensation inside the cabinet.

Auxiliary Switch

The auxiliary switch used in control circuits and interlocking schemes is installed within the motor operator housing. Contacts are field adjustable via an Allen wrench without disassembly of the auxiliary switch.

Standard Features

- Position Indicating Lights
- Dead Front Panel
- Open-Close Pushbuttons
- Decoupler for Vertical Operating Pipe
- 12-Stage Auxiliary Switch (8 stages of which are for customer use)
- 120 VAC or 240 VAC, Thermostatically Controlled, 100-Watt Heater
- Operations Counter
- Fused Pullouts for Motor and Heater Circuits (provides visible open circuit)
- NEMA 56 Frame Size Motor (48 VDC or 125 VDC)
- 2 Hinged, Removable Doors
- Manual Crank Handle (insertion automatically disconnects motor circuit)
- Internal Cabinet Light with Toggle Switch
- Local-Remote Selector Switch

Optional Features

- Extra Auxiliary Switch Stages (up to 4 additional, for a total of 16, 12 of which are for customer use)
- View Window in Front Cabinet Door
- Screened cabinet vents
- Fused Knife Switches (in lieu of fused pullouts) for Motor and Heater Circuits
- Molded Case Circuit Breakers (in lieu of fused pullouts) for Motor and Heater Circuits
- Terminal Lug for Cabinet Grounding
- Door Actuated Light Switch (in lieu of toggle switch)
- Trip Circuit Monitoring Relay
- Loss of Voltage Relays
- Duplex Receptacle with GFCI
- Bridge Rectifier (allows 120 VAC input to be converted into 125 VDC for use in operating DC internal components of the motor operator)
- Contact Southern States for Availability of Optional Features Not Listed.

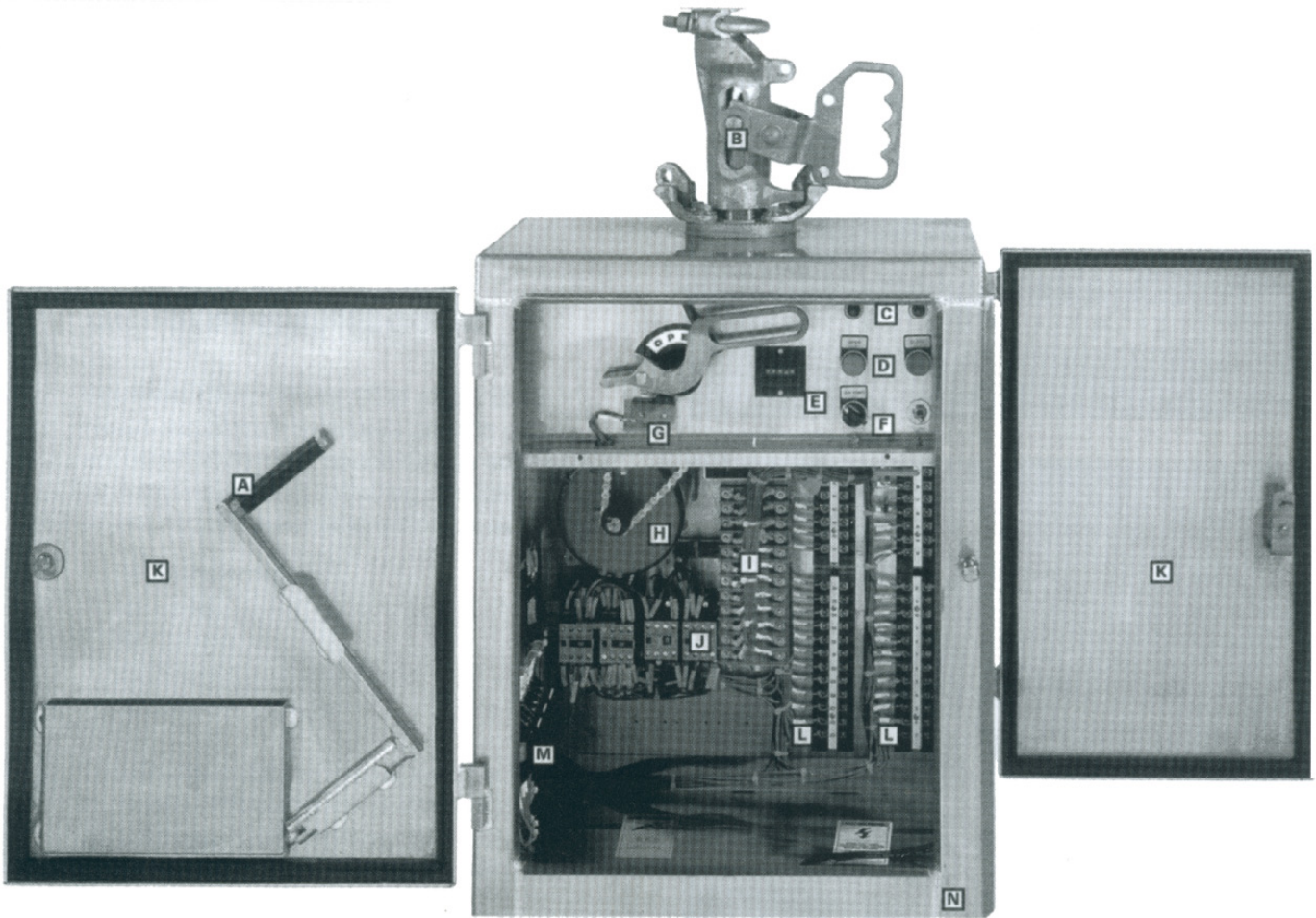

Feature Location

- A** Manual Crank Handle
- B** Decoupler (pistol grip type shown; pin type also available [and swing handle type is available for disconnect switch applications])
- C** Indicating Lights
- D** Open & Close Pushbuttons
- E** Operations Counter
- F** Local-Remote Selector Switch
- G** Hand Crank Interlock Switch
- H** Motor, 48 VDC or 125 VDC
- I** Auxiliary Switches
- J** Anti-Pump Relay, Time Delay Relay, and Reversing Contactor
- K** Hinged Removable Doors (2)
- L** Terminal Blocks (4)
- M** Fused Pullouts
- N** Aluminum Cabinet



The Quality Name In High Voltage Switching

30 Georgia Avenue
Hampton, Georgia 30228
Phone (770) 946-4562
Fax (770) 946-8106
e-mail: sales@southernstatesLLC.com
<http://www.southernstatesLLC.com>

© 2017 Southern States, LLC
PB 803-40 CSH CSH-B-R5 01062017
Printed in the U.S.A.